

SECTION 230130.52 - EXISTING HVAC AIR DISTRIBUTION SYSTEM CLEANING

PART 1 - GENERAL

1.1 RELATED DOCUMENTS

- A. Drawings and general provisions of the Contract, including General and Supplementary Conditions and Division 01 Specification Sections, apply to this Section.

1.2 SUMMARY

- A. Section includes cleaning existing HVAC air-distribution equipment, ducts, plenums, and system components.
- B. Related Requirements:
 - 1. Division 23 Section "Metal Ducts" for cleaning newly installed metal ducts.
 - 2. Division 23 Section "Testing, Adjusting, Balancing for HVAC" for system flow documentation before cleaning and balancing and following cleaning and restoration.
 - 3. Division 23 Section "Air Duct Accessories" for restoration of opened ducts and plenums with access doors.

1.3 DEFINITIONS

- A. ACAC: American Council for Accredited Certification.
- B. AIHA-LAP: American Industrial Hygiene Association Lab Accreditation Program
- C. ASCS: Air systems cleaning specialist.
- D. CESB: Council of Engineering and Scientific Specialty Boards.
- E. CMI: Certified Microbial Investigator.
- F. CMC: Certified Microbial Consultant.
- G. CMR: Certified Microbial Remediator.
- H. CMRS: Certified Microbial Remediation Supervisor.
- I. EMLAP: Environmental Microbiology Laboratory Accreditation Program.
- J. IEP: Indoor Environmental Professional.

- K. IICRC: Institute of Inspection, Cleaning, and Restoration Certification.
- L. NADCA: National Air Duct Cleaners Association.

1.4 ACTION SUBMITTALS

- A. Product Data:
 - 1. Cleaning agents
 - 2. Antimicrobial surface treatments ("sealant" for sustainable design submittal purposes).

1.5 INFORMATIONAL SUBMITTALS

- A. Qualification Data:
 - 1. For an ASCS.
 - 2. For an IEP.
 - 3. For a CMR and a CMRS.
- B. Field Quality-Control Reports:
 - 1. Project's existing conditions.
 - 2. Evaluations and recommendations, including cleanliness verification.
 - 3. Strategies and procedures plan.

1.6 CLOSEOUT SUBMITTALS

- A. Post-Project report.

1.7 QUALITY ASSURANCE

- A. ASCS Qualifications: A certified member of NADCA.
 - 1. Certification: Employ an ASCS certified by NADCA on a full-time basis.
 - 2. Supervisor Qualifications: Certified as an ASCS by NADCA.
- B. IEP Qualifications: CMI who is certified by ACAC and accredited by CESB.
- C. IEP Qualifications: CMC who is certified by ACAC and accredited by CESB.

- D. CMR Qualifications: Certified by ACAC and accredited by CESB.
- E. CMRS Qualifications: Certified by ACAC and accredited by CESB.
- F. UL Compliance: Comply with UL 181 and UL 181A for fibrous-glass ducts.
- G. Cleaning Conference: Conduct conference at Project site.
 - 1. Review methods and procedures related to HVAC air-distribution system cleaning, including, but not limited to, review of the cleaning strategies and procedures plan.

PART 2 - PRODUCTS

2.1 HVAC CLEANING AGENTS

- A. Manufacturers: Subject to compliance with Requirements, available manufacturers offering products that may be incorporated into the Work include, but are not limited to the following:
 - 1. Apex Engineering Products C
 - 2. BBJ Environmental Solutions.
 - 3. Goodway Technologies Corporation.
 - 4. Nu-Calgon.
 - 5. Quest Vapco Corporation.
- B. Description:
 - 1. Formulated for each specific soiled coil condition that needs remedy.
 - 2. Will not corrode or tarnish aluminum, copper, or other metals.

2.2 ANTIMICROBIAL SURFACE TREATMENT

- A. Manufacturers: Subject to compliance with Requirements, available manufacturers offering products that may be incorporated into the Work include, but are not limited to the following:
 - 1. Bio-Cide International, Inc.
 - 2. Contec, Inc.
 - 3. Ecolab, Inc.
- B. Description: Specific product selected shall be as recommended by the IEP based on the specific antimicrobial needs of the specific Project conditions.

1. Formulated to kill and inhibit growth of microorganisms.
2. EPA-registered for use in HVAC systems and for the specific application in which it will be used.
3. Have no residual action after drying, with zero VOC off-gassing.
4. OSHA compliant.
5. Treatment shall dry clear to allow continued visual observation of the treated surface.

PART 3 - EXECUTION

3.1 PREPARATION

- A. Inspect HVAC air-distribution equipment, ducts, plenums, and system components to determine appropriate methods, tools, and equipment required for performance of the Work.
- B. Perform "Project Evaluation and Recommendation" according to NADCA ACR.
- C. Cleaning Plan: Prepare a written plan for air-distribution system cleaning that includes strategies and step-by-step procedures. At a minimum, include the following:
 1. Supervisor contact information.
 2. Work schedule, including location, times, and impact on occupied areas.
 3. Methods and materials planned for each HVAC component type.
 4. Required support from other trades.
 5. Equipment and material storage requirements.
 6. Exhaust equipment setup locations.
- D. Existing Conditions Report: Prepare a written report that documents existing conditions of the systems and equipment. Include documentation of existing conditions, including inspection results, photo images, laboratory results, and interpretations of the laboratory results by an IEP.
 1. Prepare written report listing conditions detrimental to performance of the Work.
- E. Proceed with work only after conditions detrimental to performance of the Work have been corrected.
- F. Use the existing service openings, as required for proper cleaning, at various points of the HVAC system for physical and mechanical entry and for inspection.

- G. Comply with NADCA ACR, "Guidelines for Constructing Service Openings in HVAC Systems" Section.
- H. Mark the position of manual volume dampers and air-directional mechanical devices inside the system prior to cleaning.

3.2 CLEANING

- A. Comply with NADCA ACR, including items identified as "recommended," "advised," and "suggested."
- B. Perform electrical lockout and tagout according to Owner's standards or authorities having jurisdiction.
- C. Remove non-adhered substances and deposits from within the HVAC system.
- D. Complete cleaning in accordance with Owner-Contractor agreed-upon scope of work.
- E. Systems and Components to Be Cleaned: As identified on contract documents.
- F. Systems and Components to Be Cleaned if duct cleaning is called for within project boundary :
 - 1. Air devices for supply and return air.
 - 2. Air-terminal units and connections.
 - a. VAV boxes.
 - b. Chilled beams.
 - c. Fan coil units.
 - d. Unit ventilators.
 - e. Flexible connectors.
 - 3. Ductwork:
 - a. Supply-air ducts, including turning vanes and reheat coils, to the air-handling unit.
 - b. Return-air ducts to the air-handling unit.
 - c. Exhaust-air ducts.
 - d. Transfer ducts.
 - 4. Casings.
 - 5. Duct-mounted coils.

6. Air-Handling Units:
 - a. Interior surfaces of the unit casing.
 - b. Coil surfaces compartment.
 - c. Condensate drain pans.
 - d. Fans, fan blades, and fan housings.
7. Exhaust fans and power ventilators.
8. Filters and filter housings.
9. Gravity ventilators.
10. Air-to-air heat exchangers.
- G. Collect debris removed during cleaning. Ensure that debris is not dispersed outside the HVAC system during the cleaning process.
- H. Particulate Collection:
 1. For particulate collection equipment, include adequate filtration to contain debris removed. Locate equipment downwind and away from all air intakes and other points of entry into the building.
 2. HEPA filtration with 99.97 percent collection efficiency for particles sized 0.3 micrometer or larger shall be used where the particulate collection equipment is exhausting inside the building,
- I. Control odors and mist vapors during the cleaning and restoration process.
- J. Mark the position of manual volume dampers and air-directional mechanical devices inside the system prior to cleaning. Restore them to their marked position on completion of cleaning.
- K. System components shall be cleaned so that all HVAC system components are visibly clean. On completion, all components must be returned to those settings recorded just prior to cleaning operations.
- L. Clean all air-distribution devices, registers, grilles, and diffusers.
- M. Clean non-adhered substance deposits according to NADCA ACR and the following:
 1. Clean air-handling units, airstream surfaces, components, condensate collectors, and drains.
 2. Ensure that a suitable operative drainage system is in place prior to beginning wash-down procedures.

3. Clean evaporator coils, reheat coils, and other airstream components.

N. Air-Distribution Systems:

1. Create service openings in the HVAC system as necessary to accommodate cleaning.
2. Mechanically clean air-distribution systems specified to remove all visible contaminants, so that the systems are capable of passing the HVAC System Cleanliness Tests (see NADCA ACR).

O. Debris removed from the HVAC system shall be disposed of according to applicable Federal, state, and local requirements.

P. Mechanical Cleaning Methodology:

1. Source-Removal Cleaning Methods: The HVAC system shall be cleaned using source-removal mechanical cleaning methods designed to extract contaminants from within the HVAC system and to safely remove these contaminants from the facility. No cleaning method, or combination of methods, shall be used that could potentially damage components of the HVAC system or negatively alter the integrity of the system.
 - a. Use continuously operating vacuum-collection devices to keep each section being cleaned under negative pressure.
 - b. Cleaning methods that require mechanical agitation devices to dislodge debris that is adhered to interior surfaces of HVAC system components shall be equipped to safely remove these devices. Cleaning methods shall not damage the integrity of HVAC system components or damage porous surface materials, such as duct and plenum liners.
2. Cleaning Mineral-Fiber Insulation Components:
 - a. Fibrous-glass thermal or acoustical insulation elements present in equipment or ductwork shall be thoroughly cleaned with HEPA vacuuming equipment while the HVAC system is under constant negative pressure and shall not be permitted to get wet according to NADCA ACR.
 - b. Cleaning methods used shall not cause damage to fibrous-glass components and will render the system capable of passing the HVAC System Cleanliness Tests (see NADCA ACR).
 - c. Fibrous materials that become wet shall be discarded and replaced.

Q. Coil Cleaning:

1. See NADCA ACR, "Coil Surface Cleaning" Section. Type 1, or Type 1 and Type 2, cleaning methods shall be used to render the coil visibly clean and capable of passing coil cleaning verification.

2. Coil drain pans shall be subject to NADCA ACR, "Non-Porous Surfaces Cleaning Verification." Ensure that condensate drain pans are operational.
3. Electric-resistance coils shall be de-energized, locked out, and tagged before cleaning.
4. Cleaning methods shall not cause any appreciable damage to, cause displacement of, inhibit heat transfer, or cause erosion of the coil surface or fins, and shall comply with coil manufacturer's written recommendations.
5. Rinse thoroughly with clean water to remove any latent residues.

R. Application of Antimicrobial Treatment:

1. Apply antimicrobial agents and coatings if active fungal growth is determined by the IEP to be at Condition 2 or Condition 3 status according to IICRC S520, as analyzed by a laboratory accredited by AIHA-LAP with an EMLAP certificate, and with results interpreted by an IEP. Apply antimicrobial agents and coatings according to manufacturer's written recommendations and EPA registration listing after the removal of surface deposits and debris.
2. Apply antimicrobial treatments and coatings after the system is rendered clean.
3. Apply antimicrobial agents and coatings directly onto surfaces of interior ductwork.
4. Microbial remediation shall be performed by a qualified CMR and CMRS.

3.3 CLEANLINESS VERIFICATION

- A. Verify cleanliness according to NADCA ACR, "Verification of HVAC System Cleanliness" Section.
- B. Verify HVAC system cleanliness after mechanical cleaning and before applying any treatment or introducing any treatment-related substance to the HVAC system, including biocidal agents and coatings.
- C. Surface-Cleaning Verification: Perform visual inspection for cleanliness. If no contaminants are evident through visual inspection, the HVAC system shall be considered clean. If visible contaminants are evident through visual inspection, those portions of the system where contaminants are visible shall be re-cleaned and subjected to re-inspection for cleanliness.
- D. Verification of Coil Cleaning:
 1. Measure static-pressure differential across each coil.
 2. Coil will be considered clean if cleaning restored the coil static-pressure differential within 10 percent of the differential measured when the coil was first installed.
- E. Verification of Coil Cleaning: Coil will be considered clean if the coil is free of foreign matter and chemical residue, based on a thorough visual inspection.

- F. Additional Verification:
 - 1. Perform surface comparison testing or NADCA vacuum test.
 - 2. Conduct NADCA vacuum gravimetric test analysis for nonporous surfaces.
- G. Prepare a written cleanliness verification report. At a minimum, include the following:
 - 1. Written documentation of the success of the cleaning.
 - 2. Site inspection reports, initialed by supervisor, including notation on areas of inspection, as verified through visual inspection.
 - 3. Surface comparison test results if required.
 - 4. Gravimetric analysis (nonporous surfaces only).
 - 5. System areas found to be damaged.
- H. Photographic Documentation: Comply with requirements in Section 013233 "Photographic Documentation."

3.4 RESTORATION

- A. Restore and repair HVAC air-distribution equipment, ducts, plenums, and components according to NADCA ACR, "Restoration and Repair of Mechanical Systems" Section.
- B. Restore service openings capable of future reopening. Comply with requirements in Section 233113 "Metal Ducts."
- C. Reseal fibrous-glass ducts. Comply with requirements in Section 233116 "Nonmetal Ducts."
- D. Replace fibrous-glass materials that cannot be restored by cleaning or resurfacing. Comply with requirements in Section 233113 "Metal Ducts" and Section 233116 "Nonmetal Ducts."
- E. Replace damaged insulation according to Section 230713 "Duct Insulation."
- F. Ensure that closures do not hinder or alter airflow.
- G. New closure materials, including insulation, shall match opened materials and shall have removable closure panels fitted with gaskets and fasteners.
- H. Restore manual volume dampers and air-directional mechanical devices inside the system to their marked position on completion of cleaning.
- I. Measure air flows through air-distribution system.
- J. Measure static-pressure differential across each coil.

3.5 PROJECT CLOSEOUT

A. Post-Project Report:

1. Post-cleaning laboratory results if any.
2. Post-cleaning photo images.
3. Post-cleaning verification summary.

B. Drawings:

1. Deviations of existing system from Owner's record drawings.
2. Location of service openings.

END OF SECTION 230130.52

SECTION 230513 - COMMON MOTOR REQUIREMENTS FOR HVAC EQUIPMENT

PART 1 - GENERAL

1.1 RELATED DOCUMENTS

- A. Drawings and general provisions of the Contract, including General and Supplementary Conditions and Division 01 Specification Sections, apply to this Section.

1.2 SUMMARY

- A. Section includes general requirements for single-phase and polyphase, general-purpose, horizontal, small and medium, squirrel-cage induction motors for use on alternating-current power systems up to 600 V and installed at equipment manufacturer's factory or shipped separately by equipment manufacturer for field installation.

1.3 COORDINATION

- A. Coordinate features of motors, installed units, and accessory devices to be compatible with the following:
 - 1. Motor controllers.
 - 2. Torque, speed, and horsepower requirements of the load.
 - 3. Ratings and characteristics of supply circuit and required control sequence.
 - 4. Ambient and environmental conditions of installation location.

PART 2 - PRODUCTS

2.1 GENERAL MOTOR REQUIREMENTS

- A. Comply with NEMA MG 1 unless otherwise indicated.
- B. Comply with IEEE 841 for severe-duty motors.
- C. Inverter-Duty Motors shall comply with NEMA MG-1 Section IV part 3.
- D. VFD driven Motors need to be provided with shaft grounding rings.

2.2 MOTOR CHARACTERISTICS

- A. Duty: Continuous duty at ambient temperature of 40 deg C and at altitude of 3300 feet above sea level.
- B. Capacity and Torque Characteristics: Sufficient to start, accelerate, and operate connected loads at designated speeds, at installed altitude and environment, with indicated operating sequence, and without exceeding nameplate ratings or considering service factor.

2.3 POLYPHASE MOTORS

- A. Description: NEMA MG 1, Design B, medium induction motor.
- B. Efficiency: Premium efficient, as defined in NEMA MG 1.
- C. Service Factor: 1.15.
- D. Multispeed Motors: Variable torque.
 - 1. For motors with 2:1 speed ratio, consequent pole, single winding.
 - 2. For motors with other than 2:1 speed ratio, separate winding for each speed.
- E. Multispeed Motors: Separate winding for each speed.
- F. Rotor: Random-wound, squirrel cage.
- G. Bearings: Regreasable, shielded, antifriction ball bearings suitable for radial and thrust loading.
- H. Temperature Rise: Match insulation rating.
- I. Insulation: Class F.
- J. Code Letter Designation:
 - 1. Motors 15 HP and Larger: NEMA starting Code F or Code G.
 - 2. Motors Smaller Than 5 HP: Manufacturer's standard starting characteristic.
- K. Enclosure Material: Cast iron for motor frame sizes 324T and larger; rolled steel for motor frame sizes smaller than 324T.

2.4 ADDITIONAL REQUIREMENTS FOR POLYPHASE MOTORS

- A. Motors Used with Reduced-Voltage and Multispeed Controllers: Match wiring connection requirements for controller with required motor leads. Provide terminals in motor terminal box, suited to control method.

- B. Motors Used with Variable-Frequency Controllers: Ratings, characteristics, and features coordinated with and approved by controller manufacturer.
 - 1. Windings: Copper magnet wire with moisture-resistant insulation varnish, designed and tested to resist transient spikes, high frequencies, and short time rise pulses produced by pulse-width-modulated inverters.
 - 2. Premium-Efficient Motors: Class B temperature rise; Class F insulation.
 - 3. Inverter-Duty Motors: Class F temperature rise; Class H insulation shall comply with NEMA MG-1 Section IV part 3.
 - 4. Thermal Protection: Comply with NEMA MG 1 requirements for thermally protected motors.
 - 5. Provide shaft grounding rings.
- C. Severe-Duty Motors: Comply with IEEE 841, with 1.15 minimum service factor.

2.5 SINGLE-PHASE MOTORS

- A. Motors larger than 1/20 hp shall be one of the following, to suit starting torque and requirements of specific motor application:
 - 1. Permanent-split capacitor.
 - 2. Split phase.
 - 3. Capacitor start, inductor run.
 - 4. Capacitor start, capacitor run.
- B. Multispeed Motors: Variable-torque, permanent-split-capacitor type.
- C. Bearings: Prelubricated, antifriction ball bearings or sleeve bearings suitable for radial and thrust loading.
- D. Motors 1/20 HP and Smaller: Shaded-pole type.
- E. Thermal Protection: Internal protection to automatically open power supply circuit to motor when winding temperature exceeds a safe value calibrated to temperature rating of motor insulation. Thermal-protection device shall automatically reset when motor temperature returns to normal range.

PART 3 - EXECUTION (Not Applicable)

END OF SECTION 230513

SECTION 230519 - METERS AND GAGES FOR HVAC PIPING

PART 1 - GENERAL

1.1 RELATED DOCUMENTS

- A. Drawings and general provisions of the Contract, including General and Supplementary Conditions and Division 01 Specification Sections, apply to this Section.

1.2 SUMMARY

- A. Section Includes:

1. Bimetallic-actuated thermometers.
2. Filled-system thermometers.
3. Liquid-in-glass thermometers.
4. Digital Solar-Powered Thermometer
5. Thermowells.
6. Dial-type pressure gages.
7. Gage attachments.
8. Test plugs.
9. Test-plug kits.
10. Sight flow indicators.
11. Orifice flowmeters.
12. Pitot-tube flowmeters.

- B. Related Sections:

1. Division 23 Section "Steam and Condensate Heating Piping Accessories" for steam and condensate accessories.

1.3 SUBMITTALS

- A. Product Data: For each type of product indicated.
- B. Wiring Diagrams: For power, signal, and control wiring.
- C. Product Certificates: For each type of meter and gage, from manufacturer.
- D. Operation and Maintenance Data: For meters and gages to include in operation and maintenance manuals.

PART 2 - PRODUCTS

2.1 BIMETALLIC-ACTUATED THERMOMETERS

- A. Manufacturers: Subject to compliance with requirements, provide products by one of the following:
- B. Basis-of-Design Product: Subject to compliance with requirements, provide product by one of the following:
 - 1. Ashcroft Inc.
 - 2. Ernst Flow Industries.
 - 3. Marsh Bellofram.
 - 4. Miljoco Corporation.
 - 5. Nanmac Corporation.
 - 6. Noshok.
 - 7. Palmer Wahl Instrumentation Group.
 - 8. REOTEMP Instrument Corporation.
 - 9. Tel-Tru Manufacturing Company.
 - 10. Trerice, H. O. Co.
 - 11. Watts Regulator Co.; a div. of Watts Water Technologies, Inc.
 - 12. Weiss Instruments, Inc.
 - 13. WIKA Instrument Corporation - USA.
 - 14. Winters Instruments - U.S.
- C. Standard: ASME B40.200.
- D. Case: Liquid-filled and sealed type(s); stainless steel with 3-inch nominal diameter.
- E. Dial: Nonreflective aluminum with permanently etched scale markings and scales in deg F.
- F. Connector Type(s): Union joint, adjustable angle, with unified-inch screw threads.
- G. Connector Size: 1/2 inch, with ASME B1.1 screw threads.
- H. Stem: 0.375 inch in diameter; stainless steel.
- I. Window: Plain glass.
- J. Ring: Stainless steel.
- K. Element: Bimetal coil.
- L. Pointer: Dark-colored metal.
- M. Accuracy: Plus or minus 1 percent of scale range.

2.2 FILLED-SYSTEM THERMOMETERS

A. Direct-Mounted, Metal-Case, Vapor-Actuated Thermometers:

1. Manufacturers: Subject to compliance with requirements, provide products by one of the following:
2. Basis-of-Design Product: Subject to compliance with requirements, provide product by one of the following:
 - a. Ashcroft Inc.
 - b. Marsh Bellofram.
 - c. Miljoco Corporation.
 - d. Palmer Wahl Instrumentation Group.
 - e. REOTEMP Instrument Corporation.
 - f. Terice, H. O. Co.
 - g. Weiss Instruments, Inc.
3. Standard: ASME B40.200.
4. Case: Sealed type, cast aluminum or drawn steel; 4-1/2-inch nominal diameter.
5. Element: Bourdon tube or other type of pressure element.
6. Movement: Mechanical, dampening type, with link to pressure element and connection to pointer.
7. Dial: Nonreflective aluminum with permanently etched scale markings graduated in deg F.
8. Pointer: Dark-colored metal.
9. Window: Glass.
10. Ring: Stainless steel.
11. Connector Type(s): Union joint, adjustable, 180 degrees in vertical plane,; with ASME B1.1 screw threads.
12. Thermal System: Liquid-filled bulb in copper-plated steel, aluminum, or brass stem and of length to suit installation.
 - a. Design for Air-Duct Installation: With ventilated shroud.
 - b. Design for Thermowell Installation: Bare stem.
13. Accuracy: Plus or minus 1 percent of scale range.

2.3 LIQUID-IN-GLASS THERMOMETERS

A. Metal-Case, Compact-Style, Liquid-in-Glass Thermometers:

1. Manufacturers: Subject to compliance with requirements, provide products by one of the following:
2. Basis-of-Design Product: Subject to compliance with requirements, provide product by one of the following:
 - a. Terice, H. O. Co.
3. Standard: ASME B40.200.

4. Case: Cast aluminum; 6-inch nominal size.
5. Case Form: Straight unless otherwise indicated.
6. Tube: Glass with magnifying lens and blue organic liquid.
7. Tube Background: Nonreflective aluminum with permanently etched scale markings graduated in deg F.
8. Window: Glass or plastic.
9. Stem: Aluminum or brass and of length to suit installation.
 - a. Design for Air-Duct Installation: With ventilated shroud.
 - b. Design for Thermowell Installation: Bare stem.
10. Connector: 3/4 inch, with ASME B1.1 screw threads.
11. Accuracy: Plus or minus 1 percent of scale range or one scale division, to a maximum of 1.5 percent of scale range.

B. Plastic-Case, Compact-Style, Liquid-in-Glass Thermometers:

1. Manufacturers: Subject to compliance with requirements, provide products by one of the following:
2. Basis-of-Design Product: Subject to compliance with requirements, provide product by one of the following:
 - a. Flo Fab Inc.
 - b. Miljoco Corporation.
 - c. Tel-Tru Manufacturing Company.
 - d. Watts Regulator Co.; a div. of Watts Water Technologies, Inc.
 - e. Weiss Instruments, Inc.
 - f. WIKA Instrument Corporation - USA.
3. Standard: ASME B40.200.
4. Case: Plastic; 6-inch nominal size.
5. Case Form: Straight unless otherwise indicated.
6. Tube: Glass with magnifying lens and blue organic liquid.
7. Tube Background: Nonreflective with permanently etched scale markings graduated in deg F.
8. Window: Glass or plastic.
9. Stem: Aluminum or brass and of length to suit installation.
 - a. Design for Air-Duct Installation: With ventilated shroud.
 - b. Design for Thermowell Installation: Bare stem.
10. Connector: 3/4 inch, with ASME B1.1 screw threads.
11. Accuracy: Plus or minus 1 percent of scale range or one scale division, to a maximum of 1.5 percent of scale range.

C. Metal-Case, Industrial-Style, Liquid-in-Glass Thermometers:

1. Manufacturers: Subject to compliance with requirements, provide products by one of the following:

2. Basis-of-Design Product: Subject to compliance with requirements, provide product by one of the following:
 - a. Flo Fab Inc.
 - b. Miljoco Corporation.
 - c. Palmer Wahl Instrumentation Group.
 - d. Tel-Tru Manufacturing Company.
 - e. Trerice, H. O. Co.
 - f. Weiss Instruments, Inc.
 - g. Winters Instruments - U.S.
3. Standard: ASME B40.200.
4. Case: Cast aluminum; 7-inch nominal size unless otherwise indicated.
5. Case Form: Adjustable angle unless otherwise indicated.
6. Tube: Glass with magnifying lens and blue organic liquid.
7. Tube Background: Nonreflective aluminum with permanently etched scale markings graduated in deg F.
8. Window: Glass.
9. Stem: Aluminum and of length to suit installation.
 - a. Design for Air-Duct Installation: With ventilated shroud.
 - b. Design for Thermowell Installation: Bare stem.
10. Connector: 1-1/4 inches, with ASME B1.1 screw threads.
11. Accuracy: Plus or minus 1 percent of scale range or one scale division, to a maximum of 1.5 percent of scale range.

D. Plastic-Case, Industrial-Style, Liquid-in-Glass Thermometers:

1. Manufacturers: Subject to compliance with requirements, provide products by one of the following:
2. Basis-of-Design Product: Subject to compliance with requirements, provide product by one of the following:
 - a. Ernst Flow Industries.
 - b. Marsh Bellofram.
 - c. Miljoco Corporation.
 - d. Palmer Wahl Instrumentation Group.
 - e. REOTEMP Instrument Corporation.
 - f. Watts Regulator Co.; a div. of Watts Water Technologies, Inc.
 - g. Weiss Instruments, Inc.
 - h. WIKA Instrument Corporation - USA.
3. Standard: ASME B40.200.
4. Case: Plastic; 7-inch nominal size unless otherwise indicated.
5. Case Form: Adjustable angle unless otherwise indicated.
6. Tube: Glass with magnifying lens and blue organic liquid.
7. Tube Background: Nonreflective aluminum with permanently etched scale markings graduated in deg F.
8. Window: Glass.

9. Stem: Aluminum and of length to suit installation.
 - a. Design for Air-Duct Installation: With ventilated shroud.
 - b. Design for Thermowell Installation: Bare stem.
10. Connector: 1-1/4 inches, with ASME B1.1 screw threads.
11. Accuracy: Plus or minus 1 percent of scale range or one scale division, to a maximum of 1.5 percent of scale range.

2.4 DIGITAL SOLAR-POWERED THERMOMETERS

- A. Description: Light-powered digital Thermometer; thermowell applications. LCD display and an adjustable-angle stem that is fully interchangeable with industrial liquid-in-glass thermometers.
1. Case: Cast aluminum, Blue epoxy finish NEMA-4X / PP65
 2. Stem Industrial, Bimetal
 3. Connection: Bimetal 304 stainless steel stem, 1/4" diameter, 1/2 NPT.
 4. Sensor: Glass Passivated thermistor
 5. Range: -40°F to 300°F
 6. Display: 9/16" LCD read in °F/°C. Push button min/max reading with reset.
 7. Accuracy 1% or 1°F
 8. Resolution: 1/10°
 9. Update Interval: 10 Seconds
 10. Ambient Operating Temperature: -40°F to 140°F
 11. Ambient Temperature Error: None
 12. Humidity: Maximum 95% RH non-condensing
 13. Basis of Design: Trerice Sx9 or approved equal.

2.5 DUCT-THERMOMETER MOUNTING BRACKETS

- A. Description: Flanged bracket with screw holes, for attachment to air duct and made to hold thermometer stem.

2.6 THERMOWELLS

- A. Thermowells:
1. Standard: ASME B40.200.
 2. Description: Pressure-tight, socket-type fitting made for insertion into piping tee fitting.
 3. Material for Use with Copper Tubing: CNR or CUNI.
 4. Material for Use with Steel Piping: CRES.
 5. Type: Stepped shank unless straight or tapered shank is indicated.
 6. External Threads: NPS 1/2, NPS 3/4, or NPS 1, ASME B1.20.1 pipe threads.
 7. Internal Threads: 1/2, 3/4, and 1 inch, with ASME B1.1 screw threads.
 8. Bore: Diameter required to match thermometer bulb or stem.
 9. Insertion Length: Length required to match thermometer bulb or stem.
 10. Lagging Extension: Include on thermowells for insulated piping and tubing.

11. Bushings: For converting size of thermowell's internal screw thread to size of thermometer connection.

B. Heat-Transfer Medium: Mixture of graphite and glycerin.

2.7 PRESSURE GAGES

A. Direct-Mounted, Metal-Case, Dial-Type Pressure Gages:

1. Manufacturers: Subject to compliance with requirements, provide products by one of the following:
2. Basis-of-Design Product: Subject to compliance with requirements, provide product by one of the following:
 - a. AMETEK, Inc.; U.S. Gauge.
 - b. Ashcroft Inc.
 - c. Ernst Flow Industries.
 - d. Flo Fab Inc.
 - e. Marsh Bellofram.
 - f. Miljoco Corporation.
 - g. Noshok.
 - h. Palmer Wahl Instrumentation Group.
 - i. REOTEMP Instrument Corporation.
 - j. Tel-Tru Manufacturing Company.
 - k. Terice, H. O. Co.
 - l. Watts Regulator Co.; a div. of Watts Water Technologies, Inc.
 - m. Weiss Instruments, Inc.
 - n. WIKA Instrument Corporation - USA.
 - o. Winters Instruments - U.S.
3. Standard: ASME B40.100.
4. Case: Liquid-filled type(s); cast aluminum or drawn steel; 4-1/2-inch nominal diameter.
5. Pressure-Element Assembly: Bourdon tube unless otherwise indicated.
6. Pressure Connection: Brass, with NPS 1/4, ASME B1.20.1 pipe threads and bottom-outlet type unless back-outlet type is indicated.
7. Movement: Mechanical, with link to pressure element and connection to pointer.
8. Dial: Nonreflective aluminum with permanently etched scale markings graduated in psi.
9. Pointer: Dark-colored metal.
10. Window: Glass.
11. Ring: Stainless steel.
12. Accuracy: Grade A, plus or minus 1 percent of middle half of scale range.

B. Direct-Mounted, Plastic-Case, Dial-Type Pressure Gages:

1. Manufacturers: Subject to compliance with requirements, provide products by one of the following:
2. Basis-of-Design Product: Subject to compliance with requirements, provide product by one of the following:

- a. AMETEK, Inc.; U.S. Gauge.
 - b. Ashcroft Inc.
 - c. Flo Fab Inc.
 - d. Marsh Bellofram.
 - e. Miljoco Corporation.
 - f. Noshok.
 - g. Palmer Wahl Instrumentation Group.
 - h. REOTEMP Instrument Corporation.
 - i. Tel-Tru Manufacturing Company.
 - j. Terice, H. O. Co.
 - k. Weiss Instruments, Inc.
 - l. WIKA Instrument Corporation - USA.
 - m. Winters Instruments - U.S.
3. Standard: ASME B40.100.
 4. Case: Sealed type; glass; 4-1/2-inch nominal diameter.
 5. Pressure-Element Assembly: Bourdon tube unless otherwise indicated.
 6. Pressure Connection: Brass, with NPS 1/4, ASME B1.20.1 pipe threads and bottom-outlet type unless back-outlet type is indicated.
 7. Movement: Mechanical, with link to pressure element and connection to pointer.
 8. Dial: Nonreflective aluminum with permanently etched scale markings graduated in psi.
 9. Pointer: Dark-colored metal.
 10. Window: Glass.
 11. Accuracy: Grade A, plus or minus 1 percent of middle half of scale range.

2.8 GAGE ATTACHMENTS

- A. Snubbers: ASME B40.100, brass; with NPS 1/4, ASME B1.20.1 pipe threads and piston-type surge-dampening device. Include extension for use on insulated piping.
- B. Siphons: Loop-shaped section of stainless-steel pipe with NPS 1/4 pipe threads.
- C. Valves: Brass ball, with NPS 1/4, ASME B1.20.1 pipe threads.

2.9 TEST PLUGS

- A. Manufacturers: Subject to compliance with requirements, provide products by one of the following:
- B. Basis-of-Design Product: Subject to compliance with requirements, provide product by one of the following:
 1. Flow Design, Inc.
 2. Miljoco Corporation.
 3. National Meter, Inc.
 4. Peterson Equipment Co., Inc.
 5. Sisco Manufacturing Company, Inc.
 6. Terice, H. O. Co.

7. Watts Regulator Co.; a div. of Watts Water Technologies, Inc.
 8. Weiss Instruments, Inc.
- C. Description: Test-station fitting made for insertion into piping tee fitting.
- D. Body: Brass or stainless steel with core inserts and gasketed and threaded cap. Include extended stem on units to be installed in insulated piping.
- E. Thread Size: NPS 1/4, ASME B1.20.1 pipe thread.
- F. Minimum Pressure and Temperature Rating: 500 psig at 200 deg F.
- G. Core Inserts: EPDM self-sealing rubber.

2.10 TEST-PLUG KITS

- A. Manufacturers: Subject to compliance with requirements, provide products by one of the following:
- B. Basis-of-Design Product: Subject to compliance with requirements, provide product by one of the following:
1. Flow Design, Inc.
 2. Miljoco Corporation.
 3. National Meter, Inc.
 4. Peterson Equipment Co., Inc.
 5. Sisco Manufacturing Company, Inc.
 6. Trerice, H. O. Co.
 7. Watts Regulator Co.; a div. of Watts Water Technologies, Inc.
 8. Weiss Instruments, Inc.
- C. Furnish one test-plug kit(s) containing one thermometer(s), one pressure gage and adapter, and carrying case. Thermometer sensing elements, pressure gage, and adapter probes shall be of diameter to fit test plugs and of length to project into piping.
- D. Low-Range Thermometer: Small, bimetallic insertion type with 1- to 2-inch- diameter dial and tapered-end sensing element. Dial range shall be at least 25 to 125 deg F.
- E. High-Range Thermometer: Small, bimetallic insertion type with 1- to 2-inch- diameter dial and tapered-end sensing element. Dial range shall be at least 0 to 220 deg F.
- F. Pressure Gage: Small, Bourdon-tube insertion type with 2- to 3-inch- diameter dial and probe. Dial range shall be at least 0 to 200 psig.
- G. Carrying Case: Metal or plastic, with formed instrument padding.

2.11 FLOWMETERS

A. Orifice Flowmeters:

1. Manufacturers: Subject to compliance with requirements, provide products by one of the following:
2. Basis-of-Design Product: Subject to compliance with requirements, provide product by one of the following:
 - a. ABB; Instrumentation and Analytical.
 - b. Bell & Gossett; ITT Industries.
 - c. Meriam Process Technologies.
 - d. Preso Meters; a division of Racine Federated Inc.
 - e. S. A. Armstrong Limited; Armstrong Pumps Inc.
3. Description: Flowmeter with sensor, hoses or tubing, fittings, valves, indicator, and conversion chart.
4. Flow Range: Sensor and indicator shall cover operating range of equipment or system served.
5. Sensor: Wafer-orifice-type, calibrated, flow-measuring element; for installation between pipe flanges.
 - a. Design: Differential-pressure-type measurement for steam, water .
 - b. Construction: Cast-iron body, brass valves with integral check valves and caps, and calibrated nameplate.
 - c. Minimum Pressure Rating: 300 psig.
 - d. Minimum Temperature Rating: 250 deg F.
6. Permanent Indicators: Meter suitable for wall or bracket mounting, calibrated for connected sensor and having 6-inch- diameter, or equivalent, dial with fittings and copper tubing for connecting to sensor.
 - a. Scale: Gallons per minute.
 - b. Accuracy: Plus or minus 1 percent between 20 and 80 percent of scale range.

B. Pitot-Tube Flowmeters:

1. Manufacturers: Subject to compliance with requirements, provide products by one of the following:
2. Basis-of-Design Product: Subject to compliance with requirements, provide product by one of the following:
 - a. ABB; Instrumentation and Analytical.
 - b. Emerson Process Management; Rosemount.
 - c. Meriam Process Technologies.
 - d. Preso Meters; a division of Racine Federated Inc.
 - e. TACO Incorporated.
 - f. Veris Industries, Inc.
3. Description: Flowmeter with sensor and indicator.

4. Flow Range: Sensor and indicator shall cover operating range of equipment or system served.
5. Sensor: Insertion type; for inserting probe into piping and measuring flow directly in gallons per minute.
 - a. Design: Differential-pressure-type measurement for water.
 - b. Construction: Stainless-steel probe of length to span inside of pipe, with integral transmitter and direct-reading scale.
 - c. Minimum Pressure Rating: 150 psig.
 - d. Minimum Temperature Rating: 250 deg F.
6. Indicator: Hand-held meter; either an integral part of sensor or a separate meter.
7. Integral Transformer: For low-voltage power connection.
8. Accuracy: Plus or minus 3 percent.
9. Display: Shows rate of flow.
10. Operating Instructions: Include complete instructions with each flowmeter.
- 11.

C. Venturi Flowmeters:

1. Manufacturers: Subject to compliance with requirements, provide products by one of the following:
2. Basis-of-Design Product: Subject to compliance with requirements, provide product by one of the following:
 - a. ABB; Instrumentation and Analytical.
 - b. Gerand Engineering Co.
 - c. Hyspan Precision Products, Inc.
 - d. Preso Meters; a division of Racine Federated Inc.
 - e. S. A. Armstrong Limited; Armstrong Pumps Inc.
 - f. Victaulic Company.
3. Description: Flowmeter with calibrated flow-measuring element, hoses or tubing, fittings, valves, indicator, and conversion chart.
4. Flow Range: Sensor and indicator shall cover operating range of equipment or system served.
5. Sensor: Venturi-type, calibrated, flow-measuring element; for installation in piping.
 - a. Design: Differential-pressure-type measurement for steam, water .
 - b. Construction: Bronze, brass, or factory-primed steel, with brass fittings and attached tag with flow conversion data.
 - c. Minimum Pressure Rating: 250 psig.
 - d. Minimum Temperature Rating: 250 deg F.
 - e. End Connections for NPS 2 and Smaller: Threaded.
 - f. End Connections for NPS 2-1/2 and Larger: Flanged or welded.
 - g. Flow Range: Flow-measuring element and flowmeter shall cover operating range of equipment or system served.

6. Permanent Indicators: Meter suitable for wall or bracket mounting, calibrated for connected flowmeter element, and having 6-inch- diameter, or equivalent, dial with fittings and copper tubing for connecting to flowmeter element.
 - a. Scale: Gallons per minute.
 - b. Accuracy: Plus or minus 1 percent between 20 and 80 percent of scale range .

PART 3 - EXECUTION

3.1 INSTALLATION

- A. Install thermowells with socket extending a minimum of 2 inches into fluid one-third of pipe diameter and in vertical position in piping tees.
- B. Install thermowells of sizes required to match thermometer connectors. Include bushings if required to match sizes.
- C. Install thermowells with extension on insulated piping.
- D. Fill thermowells with heat-transfer medium.
- E. Install direct-mounted thermometers in thermowells and adjust vertical and tilted positions.
- F. Install remote-mounted thermometer bulbs in thermowells and install cases on panels; connect cases with tubing and support tubing to prevent kinks. Use minimum tubing length.
- G. Install duct-thermometer mounting brackets in walls of ducts. Attach to duct with screws.
- H. Install direct-mounted pressure gages in piping tees with pressure gage located on pipe at the most readable position.
- I. Install remote-mounted pressure gages on panel.
- J. Install valve and snubber in piping for each pressure gage for fluids (except steam).
- K. Install valve and syphon fitting in piping for each pressure gage for steam.
- L. Install test plugs in piping tees.
- M. Install flow indicators in piping systems in accessible positions for easy viewing.
- N. Assemble and install connections, tubing, and accessories between flow-measuring elements and flowmeters according to manufacturer's written instructions.
- O. Install flowmeter elements in accessible positions in piping systems.
- P. Install wafer-orifice flowmeter elements between pipe flanges.

- Q. Install differential-pressure-type flowmeter elements, with at least minimum straight lengths of pipe, upstream and downstream from element according to manufacturer's written instructions.
- R. Install permanent indicators on walls or brackets in accessible and readable positions.
- S. Install connection fittings in accessible locations for attachment to portable indicators.
- T. Mount thermal-energy meters on wall if accessible; if not, provide brackets to support meters.
- U. Install thermometers in the following locations:
 - 1. Inlet and outlet of each hydronic zone.
 - 2. Inlet and outlet of each hydronic boiler.
 - 3. Two inlets and two outlets of each chiller.
 - 4. Inlet and outlet of each hydronic coil in air-handling units.
 - 5. Two inlets and two outlets of each hydronic heat exchanger.
 - 6. Inlet and outlet of each thermal-storage tank.
 - 7. Outside-, return-, supply-, and mixed-air ducts.
- V. Install pressure gages in the following locations:
 - 1. Discharge of each pressure-reducing valve.
 - 2. Inlet and outlet of each chiller chilled-water and condenser-water connection.
 - 3. Suction and discharge of each pump.

3.2 CONNECTIONS

- A. Install meters and gages adjacent to machines and equipment to allow service and maintenance of meters, gages, machines, and equipment.
- B. Connect flowmeter-system elements to meters.
- C. Connect flowmeter transmitters to meters.
- D. Connect thermal-energy meter transmitters to meters.

3.3 ADJUSTING

- A. After installation, calibrate meters according to manufacturer's written instructions.
- B. Adjust faces of meters and gages to proper angle for best visibility.

3.4 THERMOMETER SCHEDULE

- A. Thermometers at inlet and outlet of each hydronic zone shall be one of the following:
 - 1. Liquid-filled, bimetallic-actuated type.
 - 2. Test plug with EPDM self-sealing rubber inserts.

- B. Thermometers at inlet and outlet of each hydronic boiler shall be one of the following:
 - 1. Light-powered digital Thermometer.
 - 2. Test plug with EPDM self-sealing rubber inserts.
 - C. Thermometers at inlets and outlets of each chiller shall be one of the following:
 - 1. Light-powered digital Thermometer.
 - 2. Test plug with EPDM self-sealing rubber inserts.
 - D. Thermometers at inlet and outlet of each hydronic coil in air-handling units and built-up central systems shall be one of the following:
 - 1. Light-powered digital Thermometer.
 - 2. Test plug EPDM self-sealing rubber inserts.
 - E. Thermometers at inlets and outlets of each hydronic heat exchanger shall be one of the following:
 - 1. Light-powered digital Thermometer.
 - 2. Test plug with EPDM self-sealing rubber inserts.
 - F. Thermometers at inlet and outlet of each hydronic heat-recovery unit shall be one of the following:
 - 1. Light-powered digital Thermometer.
 - 2. Test plug EPDM self-sealing rubber inserts.
 - G. Thermometers at inlet and outlet of each thermal-storage tank shall be one of the following:
 - 1. Light-powered digital Thermometer.
 - 2. Test plug with EPDM self-sealing rubber inserts.
 - H. Thermometers at outside-, return-, supply-, and mixed-air ducts shall be one of the following:
 - 1. Liquid-filled, bimetallic-actuated type.
 - I. Thermometer stems shall be of length to match thermowell insertion length.
- 3.5 THERMOMETER SCALE-RANGE SCHEDULE
- A. Scale Range for Chilled-Water Piping: Minus 40 to plus 160 deg F.
 - B. Scale Range for Chilled-Water Piping: 0 to 100 deg F.
 - C. Scale Range for Chilled-Water Piping: 0 to 150 deg F.
 - D. Scale Range for Condenser-Water Piping: 0 to 150 deg F.
 - E. Scale Range for Heating, Hot-Water Piping: 0 to 250 deg F.

- F. Scale Range for Steam and Steam-Condensate Piping: 0 to 250 deg F.
- G. Scale Range for Air Ducts: 0 to 150 deg F.

3.6 PRESSURE-GAGE SCHEDULE

- A. Pressure gages at discharge of each pressure-reducing valve shall be one of the following:
 - 1. Liquid-filled, direct-mounted, metal case.
 - 2. Test plug with EPDM self-sealing rubber inserts.
- B. Pressure gages at inlet and outlet of each chiller chilled-water and condenser-water connection shall be one of the following:
 - 1. Liquid-filled, direct-mounted, metal case.
 - 2. Test plug with EPDM self-sealing rubber inserts.
- C. Pressure gages at suction and discharge of each pump shall be one of the following:
 - 1. Liquid-filled, direct-mounted, metal case.
 - 2. Test plug with EPDM self-sealing rubber inserts.

3.7 PRESSURE-GAGE SCALE-RANGE SCHEDULE

- A. Scale Range for Chilled-Water Piping: 0 to 160 psi.
- B. Scale Range for Condenser-Water Piping: 0 to 160 psi.
- C. Scale Range for Heating, Hot-Water Piping: 0 to 160 psi.
- D. Scale Range for Steam Piping: 0 to 300 psi.

3.8 FLOWMETER SCHEDULE

- A. Flowmeters for Chilled-Water Piping: Orifice, Pitot-tube type.
- B. Flowmeters for Condenser-Water Piping: Orifice, Pitot-tube type.
- C. Flowmeters for Heating, Hot-Water Piping: Orifice, Pitot-tube type.
- D. Flowmeters for Steam and Steam-Condensate Piping: Orifice, Venturi type.

END OF SECTION 230519

SECTION 230523 - GENERAL-DUTY VALVES FOR HVAC PIPING

PART 1 - GENERAL

1.1 RELATED DOCUMENTS

- A. Drawings and general provisions of the Contract, including General and Supplementary Conditions and Division 01 Specification Sections, apply to this Section.

1.2 SUMMARY

- A. Section Includes:

1. Bronze angle valves.
2. Brass ball valves.
3. Bronze ball valves.
4. Iron ball valves.
5. Iron, single-flange butterfly valves.
6. Iron, grooved-end butterfly valves.
7. High-performance butterfly valves.
8. Bronze lift check valves.
9. Bronze swing check valves.
10. Iron swing check valves.
11. Iron, grooved-end swing-check valves.
12. Bronze gate valves.
13. Iron gate valves.
14. Bronze globe valves.
15. Iron globe valves.
16. Lubricated plug valves.
17. Eccentric plug valves.
18. Chainwheels.

- B. Related Sections:

1. Division 23 HVAC piping Sections for specialty valves applicable to those Sections only.
2. Division 23 Section "Identification for HVAC Piping and Equipment" for valve tags and schedules.

1.3 DEFINITIONS

- A. CWP: Cold working pressure.
- B. EPDM: Ethylene propylene copolymer rubber.
- C. NBR: Acrylonitrile-butadiene, Buna-N, or nitrile rubber.

- D. NRS: Nonrising stem.
- E. OS&Y: Outside screw and yoke.
- F. RS: Rising stem.
- G. SWP: Steam working pressure.

1.4 SUBMITTALS

- A. Product Data: For each type of valve indicated.

1.5 QUALITY ASSURANCE

- A. Source Limitations for Valves: Obtain each type of valve from single source from single manufacturer.
- B. ASME Compliance:
 - 1. ASME B16.10 and ASME B16.34 for ferrous valve dimensions and design criteria.
 - 2. ASME B31.1 for power piping valves.
 - 3. ASME B31.9 for building services piping valves.

1.6 DELIVERY, STORAGE, AND HANDLING

- A. Prepare valves for shipping as follows:
 - 1. Protect internal parts against rust and corrosion.
 - 2. Protect threads, flange faces, grooves, and weld ends.
 - 3. Set angle, gate, and globe valves closed to prevent rattling.
 - 4. Set ball and plug valves open to minimize exposure of functional surfaces.
 - 5. Set butterfly valves closed or slightly open.
 - 6. Block check valves in either closed or open position.
- B. Use the following precautions during storage:
 - 1. Maintain valve end protection.
 - 2. Store valves indoors and maintain at higher than ambient dew point temperature. If outdoor storage is necessary, store valves off the ground in watertight enclosures.
- C. Use sling to handle large valves; rig sling to avoid damage to exposed parts. Do not use handwheels or stems as lifting or rigging points.

PART 2 - PRODUCTS

2.1 GENERAL REQUIREMENTS FOR VALVES

- A. Refer to HVAC valve schedule articles for applications of valves.
- B. Valve Pressure and Temperature Ratings: Not less than indicated and as required for system pressures and temperatures.
- C. Valve Sizes: Same as upstream piping unless otherwise indicated.
- D. Valve Actuator Types:
 - 1. Gear Actuator: For quarter-turn valves NPS 8 and larger.
 - 2. Handwheel: For valves other than quarter-turn types.
 - 3. Handlever: For quarter-turn valves NPS 6 and smaller except plug valves.
 - 4. Wrench: For plug valves with square heads. Furnish Owner with 1 wrench for every plug valves, for each size square plug-valve head.
 - 5. Chainwheel: Device for attachment to valve handwheel, stem, or other actuator; of size and with chain for mounting height, as indicated in the "Valve Installation" Article.
- E. Valves in Insulated Piping: With 2-inch stem extensions and the following features:
 - 1. Gate Valves: With rising stem.
 - 2. Ball Valves: With extended operating handle of non-thermal-conductive material, and protective sleeve that allows operation of valve without breaking the vapor seal or disturbing insulation.
 - 3. Butterfly Valves: With extended neck.
- F. Valve-End Connections:
 - 1. Flanged: With flanges according to ASME B16.1 for iron valves.
 - 2. Grooved: With grooves according to AWWA C606.
 - 3. Solder Joint: With sockets according to ASME B16.18.
 - 4. Threaded: With threads according to ASME B1.20.1.
- G. Valve Bypass and Drain Connections: MSS SP-45.

2.2 BRONZE ANGLE VALVES

- A. Class 125, Bronze Angle Valves with Bronze Disc:
 - 1. Manufacturers: Subject to compliance with requirements, provide products by one of the following:
 - a. Hammond Valve.
 - b. Milwaukee Valve Company.

2. Description:
 - a. Standard: MSS SP-80, Type 1.
 - b. CWP Rating: 200 psig.
 - c. Body Material: ASTM B 62, bronze with integral seat and screw-in bonnet.
 - d. Ends: Threaded.
 - e. Stem and Disc: Bronze.
 - f. Packing: Asbestos free.
 - g. Handwheel: Malleable iron or aluminum.

B. Class 125, Bronze Angle Valves with Nonmetallic Disc:

1. Manufacturers: Subject to compliance with requirements, provide products by one of the following:
 - a. American Valve, Inc.
 - b. NIBCO INC.
2. Description:
 - a. Standard: MSS SP-80, Type 2.
 - b. CWP Rating: 200 psig.
 - c. Body Material: ASTM B 62, bronze with integral seat and screw-in bonnet.
 - d. Ends: Threaded.
 - e. Stem: Bronze.
 - f. Disc: PTFE or TFE.
 - g. Packing: Asbestos free.
 - h. Handwheel: Malleable iron or aluminum.

C. Class 150, Bronze Angle Valves with Bronze Disc:

1. Manufacturers: Subject to compliance with requirements, provide products by one of the following:
 - a. Crane Co.; Crane Valve Group; Stockham Division.
 - b. Kitz Corporation.
2. Description:
 - a. Standard: MSS SP-80, Type 1.
 - b. CWP Rating: 300 psig.
 - c. Body Material: ASTM B 62, bronze with integral seat and union-ring bonnet.
 - d. Ends: Threaded.
 - e. Stem and Disc: Bronze.
 - f. Packing: Asbestos free.
 - g. Handwheel: Malleable iron or aluminum.

D. Class 150, Bronze Angle Valves with Nonmetallic Disc:

1. Manufacturers: Subject to compliance with requirements, provide products by one of the following:
 - a. Crane Co.; Crane Valve Group; Crane Valves.
 - b. Crane Co.; Crane Valve Group; Jenkins Valves.
 - c. Crane Co.; Crane Valve Group; Stockham Division.
 - d. Hammond Valve.
 - e. Milwaukee Valve Company.
 - f. NIBCO INC.
 - g. Powell Valves.

2. Description:
 - a. Standard: MSS SP-80, Type 2.
 - b. CWP Rating: 300 psig.
 - c. Body Material: ASTM B 62, bronze with integral seat and union-ring bonnet.
 - d. Ends: Threaded.
 - e. Stem: Bronze.
 - f. Disc: PTFE or TFE.
 - g. Packing: Asbestos free.
 - h. Handwheel: Malleable iron or aluminum.

2.3 BRASS BALL VALVES

A. General Requirements:

1. Ball valves utilized for vent or drain service to be provided with a brass hose connection with brass cap and chain.

B. One-Piece, Reduced-Port, Brass Ball Valves with Brass Trim:

1. Manufacturers: Subject to compliance with requirements, provide products by one of the following:
 - a. Kitz Corporation.

2. Description:
 - a. Standard: MSS SP-110.
 - b. CWP Rating: 400 psig.
 - c. Body Design: One piece.
 - d. Body Material: Forged brass.
 - e. Ends: Threaded.
 - f. Seats: PTFE or TFE.
 - g. Stem: Brass.
 - h. Ball: Chrome-plated brass.
 - i. Port: Reduced.

C. Two-Piece, Full-Port, Brass Ball Valves with Brass Trim:

1. Manufacturers: Subject to compliance with requirements, provide products by one of the following:
 - a. Crane Co.; Crane Valve Group; Crane Valves.
 - b. Crane Co.; Crane Valve Group; Jenkins Valves.
 - c. DynaQuip Controls.
 - d. Flow-Tek, Inc.; a subsidiary of Bray International, Inc.
 - e. Hammond Valve.
 - f. Jamesbury; a subsidiary of Metso Automation.
 - g. Jomar International, LTD.
 - h. Kitz Corporation.
 - i. Legend Valve.
 - j. Marwin Valve; a division of Richards Industries.
 - k. Milwaukee Valve Company.
 - l. NIBCO INC.
 - m. Red-White Valve Corporation.
 - n. RuB Inc.

2. Description:

- a. Standard: MSS SP-110.
- b. SWP Rating: 150 psig.
- c. CWP Rating: 600 psig.
- d. Body Design: Two piece.
- e. Body Material: Forged brass.
- f. Ends: Threaded.
- g. Seats: PTFE or TFE.
- h. Stem: Brass.
- i. Ball: Chrome-plated brass.
- j. Port: Full.

D. Two-Piece, Full-Port, Brass Ball Valves with Stainless-Steel Trim:

1. Manufacturers: Subject to compliance with requirements, provide products by one of the following:
 - a. Crane Co.; Crane Valve Group; Crane Valves.
 - b. Crane Co.; Crane Valve Group; Jenkins Valves.
 - c. Flow-Tek, Inc.; a subsidiary of Bray International, Inc.
 - d. Hammond Valve.
 - e. Jamesbury; a subsidiary of Metso Automation.
 - f. Kitz Corporation.
 - g. Marwin Valve; a division of Richards Industries.
 - h. Milwaukee Valve Company.
 - i. RuB Inc.

2. Description:

- a. Standard: MSS SP-110.
- b. SWP Rating: 150 psig.

- c. CWP Rating: 600 psig.
- d. Body Design: Two piece.
- e. Body Material: Forged brass.
- f. Ends: Threaded.
- g. Seats: PTFE or TFE.
- h. Stem: Stainless steel.
- i. Ball: Stainless steel, vented.
- j. Port: Full.

E. Two-Piece, Regular-Port, Brass Ball Valves with Brass Trim:

- 1. Manufacturers: Subject to compliance with requirements, provide products by one of the following:
 - a. Hammond Valve.
 - b. Jamesbury; a subsidiary of Metso Automation.
 - c. Legend Valve.
 - d. Marwin Valve; a division of Richards Industries.
 - e. Milwaukee Valve Company.
- 2. Description:
 - a. Standard: MSS SP-110.
 - b. SWP Rating: 150 psig.
 - c. CWP Rating: 600 psig.
 - d. Body Design: Two piece.
 - e. Body Material: Forged brass.
 - f. Ends: Threaded.
 - g. Seats: PTFE or TFE.
 - h. Stem: Brass.
 - i. Ball: Chrome-plated brass.
 - j. Port: Regular.

F. Two-Piece, Regular-Port, Brass Ball Valves with Stainless-Steel Trim:

- 1. Manufacturers: Subject to compliance with requirements, provide products by one of the following:
 - a. Jamesbury; a subsidiary of Metso Automation.
 - b. Marwin Valve; a division of Richards Industries.
- 2. Description:
 - a. Standard: MSS SP-110.
 - b. SWP Rating: 150 psig.
 - c. CWP Rating: 600 psig.
 - d. Body Design: Two piece.
 - e. Body Material: Brass or bronze.
 - f. Ends: Threaded.
 - g. Seats: PTFE or TFE.

- h. Stem: Stainless steel.
- i. Ball: Stainless steel, vented.
- j. Port: Regular.

G. Three-Piece, Full-Port, Brass Ball Valves with Brass Trim:

1. Manufacturers: Subject to compliance with requirements, provide products by one of the following:
 - a. Jomar International, LTD.
 - b. Kitz Corporation.
 - c. Red-White Valve Corporation.
 - d. Watts Regulator Co.; a division of Watts Water Technologies, Inc.
2. Description:
 - a. Standard: MSS SP-110.
 - b. SWP Rating: 150 psig.
 - c. CWP Rating: 600 psig.
 - d. Body Design: Three piece.
 - e. Body Material: Forged brass.
 - f. Ends: Threaded.
 - g. Seats: PTFE or TFE.
 - h. Stem: Brass.
 - i. Ball: Chrome-plated brass.
 - j. Port: Full.

H. Three-Piece, Full-Port, Brass Ball Valves with Stainless-Steel Trim:

1. Manufacturers: Subject to compliance with requirements, provide products by one of the following:
 - a. Jomar International, LTD.
 - b. Kitz Corporation.
 - c. Marwin Valve; a division of Richards Industries.
 - d. Watts Regulator Co.; a division of Watts Water Technologies, Inc.
2. Description:
 - a. Standard: MSS SP-110.
 - b. SWP Rating: 150 psig.
 - c. CWP Rating: 600 psig.
 - d. Body Design: Three piece.
 - e. Body Material: Forged brass.
 - f. Ends: Threaded.
 - g. Seats: PTFE or TFE.
 - h. Stem: Stainless steel.
 - i. Ball: Stainless steel, vented.
 - j. Port: Full.

2.4 BRONZE BALL VALVES

A. General Requirements:

1. Ball valves utilized for vent or drain service to be provided with a brass hose connection with brass cap and chain.

B. Two-Piece, Full-Port, Bronze Ball Valves with Stainless-Steel Trim:

1. Manufacturers: Subject to compliance with requirements, provide products by one of the following:
 - a. Conbraco Industries, Inc.; Apollo Valves.
 - b. Crane Co.; Crane Valve Group; Crane Valves.
 - c. Hammond Valve.
 - d. Lance Valves; a division of Advanced Thermal Systems, Inc.
 - e. Milwaukee Valve Company.
 - f. NIBCO INC.
 - g. Watts Regulator Co.; a division of Watts Water Technologies, Inc.
2. Description:
 - a. Standard: MSS SP-110.
 - b. SWP Rating: 150 psig.
 - c. CWP Rating: 600 psig.
 - d. Body Design: Two piece.
 - e. Body Material: Bronze.
 - f. Ends: Threaded.
 - g. Seats: PTFE or TFE.
 - h. Stem: Stainless steel.
 - i. Ball: Stainless steel, vented.
 - j. Port: Full.
 - k. Provide Handle Extension

C. Three-Piece, Full-Port, Bronze Ball Valves with Stainless-Steel Trim:

1. Manufacturers: Subject to compliance with requirements, provide products by one of the following:
 - a. Conbraco Industries, Inc.; Apollo Valves.
 - b. Hammond Valve.
 - c. Milwaukee Valve Company.
 - d. NIBCO INC.
2. Description:
 - a. Standard: MSS SP-110.
 - b. SWP Rating: 150 psig.
 - c. CWP Rating: 600 psig.
 - d. Body Design: Three piece.
 - e. Body Material: Bronze.

- f. Ends: Threaded.
- g. Seats: PTFE or TFE.
- h. Stem: Stainless steel.
- i. Ball: Stainless steel, vented.
- j. Port: Full.
- k. Provide Handle Extension

D. Three-Piece, Full-Port, Carbon-Steel Ball Valve:

1. Manufacturers: Subject to compliance with requirements, provide products by one of the following:
 - a. Conbraco Industries, Inc.; Apollo Valves.
 - b. Hammond Valve.
 - c. Milwaukee Valve Company.
 - d. NIBCO INC.
2. Description:
 - a. Standard: MSS SP-110.
 - b. SWP Rating: 150 psig.
 - c. CWP Rating: 750 psig.
 - d. Body Design: Three piece.
 - e. Body Material: Carbon-Steel.
 - f. Ends: Threaded.
 - g. Seats: PTFE or TFE.
 - h. Stem: Stainless steel.
 - i. Ball: Stainless steel, vented.
 - j. Port: Full.
 - k. Provide Handle Extension

2.5 IRON BALL VALVES

A. Class 125, Iron Ball Valves:

1. Manufacturers: Subject to compliance with requirements, provide products by one of the following:
 - a. American Valve, Inc.
 - b. Conbraco Industries, Inc.; Apollo Valves.
 - c. Kitz Corporation.
 - d. Sure Flow Equipment Inc.
 - e. Watts Regulator Co.; a division of Watts Water Technologies, Inc.
2. Description:
 - a. Standard: MSS SP-72.
 - b. CWP Rating: 200 psig.
 - c. Body Design: Split body.

- d. Body Material: ASTM A 126, gray iron.
- e. Ends: Flanged.
- f. Seats: PTFE or TFE.
- g. Stem: Stainless steel.
- h. Ball: Stainless steel.
- i. Port: Full.

2.6 IRON, SINGLE-FLANGE BUTTERFLY VALVES

A. 150 CWP, Iron, Single-Flange Butterfly Valves with EPDM Seat and Aluminum-Bronze Disc:

1. Manufacturers: Subject to compliance with requirements, provide products by one of the following:

- a. ABZ Valve and Controls; a division of ABZ Manufacturing, Inc.
- b. Bray Controls; a division of Bray International.
- c. Conbraco Industries, Inc.; Apollo Valves.
- d. Cooper Cameron Valves; a division of Cooper Cameron Corp.
- e. Crane Co.; Crane Valve Group; Jenkins Valves.
- f. Crane Co.; Crane Valve Group; Stockham Division.
- g. DeZurik Water Controls.
- h. Hammond Valve.
- i. Kitz Corporation.
- j. Milwaukee Valve Company.
- k. NIBCO INC.
- l. Norriseal; a Dover Corporation company.
- m. Red-White Valve Corporation.
- n. Spence Strainers International; a division of CIRCOR International.
- o. Tyco Valves & Controls; a unit of Tyco Flow Control.
- p. Watts Regulator Co.; a division of Watts Water Technologies, Inc.

2. Description:

- a. Standard: MSS SP-67, Type I.
- b. CWP Rating: 150 psig.
- c. Body Design: Lug type; suitable for bidirectional dead-end service at rated pressure without use of downstream flange.
- d. Body Material: ASTM A 126, cast iron or ASTM A 536, ductile iron.
- e. Seat: EPDM.
- f. Stem: One- or two-piece stainless steel.
- g. Disc: Aluminum bronze.

B. 150 CWP, Iron, Single-Flange Butterfly Valves with NBR Seat and Aluminum-Bronze Disc:

1. Manufacturers: Subject to compliance with requirements, provide products by one of the following:

- a. ABZ Valve and Controls; a division of ABZ Manufacturing, Inc.
- b. Bray Controls; a division of Bray International.

- c. Conbraco Industries, Inc.; Apollo Valves.
- d. Cooper Cameron Valves; a division of Cooper Cameron Corp.
- e. Crane Co.; Crane Valve Group; Jenkins Valves.
- f. Crane Co.; Crane Valve Group; Stockham Division.
- g. DeZurik Water Controls.
- h. Hammond Valve.
- i. Kitz Corporation.
- j. Milwaukee Valve Company.
- k. NIBCO INC.
- l. Norriseal; a Dover Corporation company.
- m. Red-White Valve Corporation.
- n. Spence Strainers International; a division of CIRCOR International.
- o. Tyco Valves & Controls; a unit of Tyco Flow Control.
- p. Watts Regulator Co.; a division of Watts Water Technologies, Inc.

2. Description:

- a. Standard: MSS SP-67, Type I.
- b. CWP Rating: 150 psig.
- c. Body Design: Lug type; suitable for bidirectional dead-end service at rated pressure without use of downstream flange.
- d. Body Material: ASTM A 126, cast iron or ASTM A 536, ductile iron.
- e. Seat: NBR.
- f. Stem: One- or two-piece stainless steel.
- g. Disc: Aluminum bronze.

C. 150 CWP, Iron, Single-Flange Butterfly Valves with EPDM Seat and Ductile-Iron Disc:

1. Manufacturers: Subject to compliance with requirements, provide products by one of the following:

- a. ABZ Valve and Controls; a division of ABZ Manufacturing, Inc.
- b. Bray Controls; a division of Bray International.
- c. Conbraco Industries, Inc.; Apollo Valves.
- d. Cooper Cameron Valves; a division of Cooper Cameron Corp.
- e. Crane Co.; Crane Valve Group; Center Line.
- f. Crane Co.; Crane Valve Group; Stockham Division.
- g. DeZurik Water Controls.
- h. Hammond Valve.
- i. Kitz Corporation.
- j. Milwaukee Valve Company.
- k. Mueller Steam Specialty; a division of SPX Corporation.
- l. NIBCO INC.
- m. Norriseal; a Dover Corporation company.
- n. Spence Strainers International; a division of CIRCOR International.
- o. Sure Flow Equipment Inc.
- p. Tyco Valves & Controls; a unit of Tyco Flow Control.
- q. Watts Regulator Co.; a division of Watts Water Technologies, Inc.

2. Description:

- a. Standard: MSS SP-67, Type I.
- b. CWP Rating: 150 psig.
- c. Body Design: Lug type; suitable for bidirectional dead-end service at rated pressure without use of downstream flange.
- d. Body Material: ASTM A 126, cast iron or ASTM A 536, ductile iron.
- e. Seat: EPDM.
- f. Stem: One- or two-piece stainless steel.
- g. Disc: Nickel-plated or -coated ductile iron.

D. 150 CWP, Iron, Single-Flange Butterfly Valves with NBR Seat and Ductile-Iron Disc:

1. Manufacturers: Subject to compliance with requirements, provide products by one of the following:

- a. ABZ Valve and Controls; a division of ABZ Manufacturing, Inc.
- b. Bray Controls; a division of Bray International.
- c. Conbraco Industries, Inc.; Apollo Valves.
- d. Cooper Cameron Valves; a division of Cooper Cameron Corp.
- e. Crane Co.; Crane Valve Group; Center Line.
- f. Crane Co.; Crane Valve Group; Stockham Division.
- g. DeZurik Water Controls.
- h. Hammond Valve.
- i. Kitz Corporation.
- j. Milwaukee Valve Company.
- k. Mueller Steam Specialty; a division of SPX Corporation.
- l. NIBCO INC.
- m. Norriseal; a Dover Corporation company.
- n. Spence Strainers International; a division of CIRCOR International.
- o. Sure Flow Equipment Inc.
- p. Tyco Valves & Controls; a unit of Tyco Flow Control.
- q. Watts Regulator Co.; a division of Watts Water Technologies, Inc.

2. Description:

- a. Standard: MSS SP-67, Type I.
- b. CWP Rating: 150 psig.
- c. Body Design: Lug type; suitable for bidirectional dead-end service at rated pressure without use of downstream flange.
- d. Body Material: ASTM A 126, cast iron or ASTM A 536, ductile iron.
- e. Seat: NBR.
- f. Stem: One- or two-piece stainless steel.
- g. Disc: Nickel-plated or -coated ductile iron.

E. 150 CWP, Iron, Single-Flange Butterfly Valves with EPDM Seat and Stainless-Steel Disc:

1. Manufacturers: Subject to compliance with requirements, provide products by one of the following:

- a. ABZ Valve and Controls; a division of ABZ Manufacturing, Inc.
- b. Bray Controls; a division of Bray International.

- c. Conbraco Industries, Inc.; Apollo Valves.
- d. Cooper Cameron Valves; a division of Cooper Cameron Corp.
- e. Crane Co.; Crane Valve Group; Jenkins Valves.
- f. Crane Co.; Crane Valve Group; Stockham Division.
- g. DeZurik Water Controls.
- h. Hammond Valve.
- i. Kitz Corporation.
- j. Milwaukee Valve Company.
- k. Mueller Steam Specialty; a division of SPX Corporation.
- l. NIBCO INC.
- m. Norriseal; a Dover Corporation company.
- n. Red-White Valve Corporation.
- o. Spence Strainers International; a division of CIRCOR International.
- p. Sure Flow Equipment Inc.
- q. Tyco Valves & Controls; a unit of Tyco Flow Control.
- r. Watts Regulator Co.; a division of Watts Water Technologies, Inc.

2. Description:

- a. Standard: MSS SP-67, Type I.
- b. CWP Rating: 150 psig.
- c. Body Design: Lug type; suitable for bidirectional dead-end service at rated pressure without use of downstream flange.
- d. Body Material: ASTM A 126, cast iron or ASTM A 536, ductile iron.
- e. Seat: EPDM.
- f. Stem: One- or two-piece stainless steel.
- g. Disc: Stainless steel.

F. 150 CWP, Iron, Single-Flange Butterfly Valves with NBR Seat and Stainless-Steel Disc:

1. Manufacturers: Subject to compliance with requirements, provide products by one of the following:
 - a. ABZ Valve and Controls; a division of ABZ Manufacturing, Inc.
 - b. Bray Controls; a division of Bray International.
 - c. Conbraco Industries, Inc.; Apollo Valves.
 - d. Cooper Cameron Valves; a division of Cooper Cameron Corp.
 - e. Crane Co.; Crane Valve Group; Jenkins Valves.
 - f. Crane Co.; Crane Valve Group; Stockham Division.
 - g. DeZurik Water Controls.
 - h. Hammond Valve.
 - i. Kitz Corporation.
 - j. Milwaukee Valve Company.
 - k. Mueller Steam Specialty; a division of SPX Corporation.
 - l. NIBCO INC.
 - m. Norriseal; a Dover Corporation company.
 - n. Red-White Valve Corporation.
 - o. Spence Strainers International; a division of CIRCOR International.
 - p. Sure Flow Equipment Inc.
 - q. Watts Regulator Co.; a division of Watts Water Technologies, Inc.

2. Description:

- a. Standard: MSS SP-67, Type I.
- b. CWP Rating: 150 psig.
- c. Body Design: Lug type; suitable for bidirectional dead-end service at rated pressure without use of downstream flange.
- d. Body Material: ASTM A 126, cast iron or ASTM A 536, ductile iron.
- e. Seat: NBR.
- f. Stem: One- or two-piece stainless steel.
- g. Disc: Stainless steel.

G. 200 CWP, Iron, Single-Flange Butterfly Valves with EPDM Seat and Aluminum-Bronze Disc:

1. Manufacturers: Subject to compliance with requirements, provide products by one of the following:

- a. ABZ Valve and Controls; a division of ABZ Manufacturing, Inc.
- b. Conbraco Industries, Inc.; Apollo Valves.
- c. Cooper Cameron Valves; a division of Cooper Cameron Corp.
- d. Crane Co.; Crane Valve Group; Jenkins Valves.
- e. Crane Co.; Crane Valve Group; Stockham Division.
- f. DeZurik Water Controls.
- g. Flo Fab Inc.
- h. Hammond Valve.
- i. Kitz Corporation.
- j. Legend Valve.
- k. Milwaukee Valve Company.
- l. NIBCO INC.
- m. Norriseal; a Dover Corporation company.
- n. Red-White Valve Corporation.
- o. Spence Strainers International; a division of CIRCOR International.
- p. Watts Regulator Co.; a division of Watts Water Technologies, Inc.

2. Description:

- a. Standard: MSS SP-67, Type I.
- b. CWP Rating: 200 psig.
- c. Body Design: Lug type; suitable for bidirectional dead-end service at rated pressure without use of downstream flange.
- d. Body Material: ASTM A 126, cast iron or ASTM A 536, ductile iron.
- e. Seat: EPDM.
- f. Stem: One- or two-piece stainless steel.
- g. Disc: Aluminum bronze.

H. 200 CWP, Iron, Single-Flange Butterfly Valves with NBR Seat and Aluminum-Bronze Disc:

1. Manufacturers: Subject to compliance with requirements, provide products by one of the following:

- a. ABZ Valve and Controls; a division of ABZ Manufacturing, Inc.

- b. Conbraco Industries, Inc.; Apollo Valves.
- c. Cooper Cameron Valves; a division of Cooper Cameron Corp.
- d. Crane Co.; Crane Valve Group; Jenkins Valves.
- e. Crane Co.; Crane Valve Group; Stockham Division.
- f. DeZurik Water Controls.
- g. Flo Fab Inc.
- h. Hammond Valve.
- i. Kitz Corporation.
- j. Legend Valve.
- k. Milwaukee Valve Company.
- l. NIBCO INC.
- m. Norriseal; a Dover Corporation company.
- n. Red-White Valve Corporation.
- o. Spence Strainers International; a division of CIRCOR International.
- p. Watts Regulator Co.; a division of Watts Water Technologies, Inc.

2. Description:

- a. Standard: MSS SP-67, Type I.
- b. CWP Rating: 200 psig.
- c. Body Design: Lug type; suitable for bidirectional dead-end service at rated pressure without use of downstream flange.
- d. Body Material: ASTM A 126, cast iron or ASTM A 536, ductile iron.
- e. Seat: NBR.
- f. Stem: One- or two-piece stainless steel.
- g. Disc: Aluminum bronze.

I. 200 CWP, Iron, Single-Flange Butterfly Valves with EPDM Seat and Ductile-Iron Disc:

- 1. Manufacturers: Subject to compliance with requirements, provide products by one of the following:
 - a. ABZ Valve and Controls; a division of ABZ Manufacturing, Inc.
 - b. American Valve, Inc.
 - c. Conbraco Industries, Inc.; Apollo Valves.
 - d. Cooper Cameron Valves; a division of Cooper Cameron Corp.
 - e. Crane Co.; Crane Valve Group; Center Line.
 - f. Crane Co.; Crane Valve Group; Stockham Division.
 - g. DeZurik Water Controls.
 - h. Flo Fab Inc.
 - i. Hammond Valve.
 - j. Kitz Corporation.
 - k. Legend Valve.
 - l. Milwaukee Valve Company.
 - m. Mueller Steam Specialty; a division of SPX Corporation.
 - n. NIBCO INC.
 - o. Norriseal; a Dover Corporation company.
 - p. Spence Strainers International; a division of CIRCOR International.
 - q. Sure Flow Equipment Inc.
 - r. Watts Regulator Co.; a division of Watts Water Technologies, Inc.

2. Description:

- a. Standard: MSS SP-67, Type I.
- b. CWP Rating: 200 psig.
- c. Body Design: Lug type; suitable for bidirectional dead-end service at rated pressure without use of downstream flange.
- d. Body Material: ASTM A 126, cast iron or ASTM A 536, ductile iron.
- e. Seat: EPDM.
- f. Stem: One- or two-piece stainless steel.
- g. Disc: Nickel-plated or -coated ductile iron.

J. 200 CWP, Iron, Single-Flange Butterfly Valves with NBR Seat and Ductile-Iron Disc:

1. Manufacturers: Subject to compliance with requirements, provide products by one of the following:

- a. ABZ Valve and Controls; a division of ABZ Manufacturing, Inc.
- b. American Valve, Inc.
- c. Conbraco Industries, Inc.; Apollo Valves.
- d. Cooper Cameron Valves; a division of Cooper Cameron Corp.
- e. Crane Co.; Crane Valve Group; Center Line.
- f. Crane Co.; Crane Valve Group; Stockham Division.
- g. DeZurik Water Controls.
- h. Flo Fab Inc.
- i. Hammond Valve.
- j. Kitz Corporation.
- k. Legend Valve.
- l. Milwaukee Valve Company.
- m. Mueller Steam Specialty; a division of SPX Corporation.
- n. NIBCO INC.
- o. Norriseal; a Dover Corporation company.
- p. Spence Strainers International; a division of CIRCOR International.
- q. Sure Flow Equipment Inc.
- r. Watts Regulator Co.; a division of Watts Water Technologies, Inc.

2. Description:

- a. Standard: MSS SP-67, Type I.
- b. CWP Rating: 200 psig.
- c. Body Design: Lug type; suitable for bidirectional dead-end service at rated pressure without use of downstream flange.
- d. Body Material: ASTM A 126, cast iron or ASTM A 536, ductile iron.
- e. Seat: NBR.
- f. Stem: One- or two-piece stainless steel.
- g. Disc: Nickel-plated or -coated ductile iron.

K. 200 CWP, Iron, Single-Flange Butterfly Valves with EPDM Seat and Stainless-Steel Disc:

1. Manufacturers: Subject to compliance with requirements, provide products by one of the following:

- a. ABZ Valve and Controls; a division of ABZ Manufacturing, Inc.
- b. American Valve, Inc.
- c. Conbraco Industries, Inc.; Apollo Valves.
- d. Cooper Cameron Valves; a division of Cooper Cameron Corp.
- e. Crane Co.; Crane Valve Group; Jenkins Valves.
- f. Crane Co.; Crane Valve Group; Stockham Division.
- g. DeZurik Water Controls.
- h. Flo Fab Inc.
- i. Hammond Valve.
- j. Kitz Corporation.
- k. Legend Valve.
- l. Milwaukee Valve Company.
- m. Mueller Steam Specialty; a division of SPX Corporation.
- n. NIBCO INC.
- o. Norriseal; a Dover Corporation company.
- p. Red-White Valve Corporation.
- q. Spence Strainers International; a division of CIRCOR International.
- r. Sure Flow Equipment Inc.
- s. Watts Regulator Co.; a division of Watts Water Technologies, Inc.

2. Description:

- a. Standard: MSS SP-67, Type I.
- b. CWP Rating: 200 psig.
- c. Body Design: Lug type; suitable for bidirectional dead-end service at rated pressure without use of downstream flange.
- d. Body Material: ASTM A 126, cast iron or ASTM A 536, ductile iron.
- e. Seat: EPDM.
- f. Stem: One- or two-piece stainless steel.
- g. Disc: Stainless steel.

L. 200 CWP, Iron, Single-Flange Butterfly Valves with NBR Seat and Stainless-Steel Disc:

1. Manufacturers: Subject to compliance with requirements, provide products by one of the following:
 - a. ABZ Valve and Controls; a division of ABZ Manufacturing, Inc.
 - b. American Valve, Inc.
 - c. Conbraco Industries, Inc.; Apollo Valves.
 - d. Cooper Cameron Valves; a division of Cooper Cameron Corp.
 - e. Crane Co.; Crane Valve Group; Jenkins Valves.
 - f. Crane Co.; Crane Valve Group; Stockham Division.
 - g. DeZurik Water Controls.
 - h. Flo Fab Inc.
 - i. Hammond Valve.
 - j. Kitz Corporation.
 - k. Legend Valve.
 - l. Milwaukee Valve Company.
 - m. Mueller Steam Specialty; a division of SPX Corporation.
 - n. NIBCO INC.

- o. Norriseal; a Dover Corporation company.
- p. Red-White Valve Corporation.
- q. Spence Strainers International; a division of CIRCOR International.
- r. Sure Flow Equipment Inc.
- s. Watts Regulator Co.; a division of Watts Water Technologies, Inc.

2. Description:

- a. Standard: MSS SP-67, Type I.
- b. CWP Rating: 200 psig.
- c. Body Design: Lug type; suitable for bidirectional dead-end service at rated pressure without use of downstream flange.
- d. Body Material: ASTM A 126, cast iron or ASTM A 536, ductile iron.
- e. Seat: NBR.
- f. Stem: One- or two-piece stainless steel.
- g. Disc: Stainless steel.

2.7 IRON, GROOVED-END BUTTERFLY VALVES

A. 175 CWP, Iron, Grooved-End Butterfly Valves:

- 1. Manufacturers: Subject to compliance with requirements, provide products by one of the following:
 - a. Kennedy Valve; a division of McWane, Inc.
 - b. Shurjoint Piping Products.
 - c. Tyco Fire Products LP; Grinnell Mechanical Products.
 - d. Victaulic Company.
- 2. Description:
 - a. Standard: MSS SP-67, Type I.
 - b. CWP Rating: 175 psig.
 - c. Body Material: Coated, ductile iron.
 - d. Stem: Two-piece stainless steel.
 - e. Disc: Coated, ductile iron.
 - f. Seal: EPDM.

B. 300 CWP, Iron, Grooved-End Butterfly Valves:

- 1. Manufacturers: Subject to compliance with requirements, provide products by one of the following:
 - a. Anvil International, Inc.
 - b. Kennedy Valve; a division of McWane, Inc.
 - c. Mueller Steam Specialty; a division of SPX Corporation.
 - d. NIBCO INC.
 - e. Shurjoint Piping Products.
 - f. Tyco Fire Products LP; Grinnell Mechanical Products.

- g. Victaulic Company.
2. Description:
- a. Standard: MSS SP-67, Type I.
 - b. NPS 8 and Smaller CWP Rating: 300 psig.
 - c. NPS 10 and Larger CWP Rating: 200 psig.
 - d. Body Material: Coated, ductile iron.
 - e. Stem: Two-piece stainless steel.
 - f. Disc: Coated, ductile iron.
 - g. Seal: EPDM.

2.8 HIGH-PERFORMANCE BUTTERFLY VALVES

A. General Requirements:

1. High performance butterfly valves shall be fully bi-directional and bi-directionally dead-endable to the full pressure rating of the seat. The seat rating can not be reduced when pressure is applied in either direction and the valve shall be capable of serving as a blank flange, when bolted to the end of a line from either side of the valve body and no mating flange is attached. The means of attaching the body to the pipe flange and of attaching the seat ring to the body shall meet the ANSI class rating of the valve without mechanical failure. Partially lugged butterfly valves are not acceptable.
2. Packing shall be able to be tightened without removing the insulation.
3. External disc position indicators shall be provided.
4. Valves must be fully factory assembled, set and tested.
5. Gear operators on steam valves shall be spaced 4" (Four Inches) above packing assembly.
6. Install all steam valves with the stem at least 30° off vertical to protect the bottom bearing from debris
7. On all butterfly valve actuators located greater than 5ft above the floor install chain wheels to 5ft above the floor.

B. Class 150, Single-Flange, High-Performance Butterfly Valves:

1. Manufacturers: Subject to compliance with requirements, provide products by one of the following:
 - a. ABZ Valve and Controls; a division of ABZ Manufacturing, Inc.
 - b. Bray Controls; a division of Bray International.
 - c. Cooper Cameron Valves; a division of Cooper Cameron Corp.
 - d. Crane Co.; Crane Valve Group; Flowseal.
 - e. Crane Co.; Crane Valve Group; Stockham Division.
 - f. DeZurik Water Controls.
 - g. Hammond Valve.
 - h. Jamesbury; a subsidiary of Metso Automation.
 - i. Milwaukee Valve Company.
 - j. NIBCO INC.
 - k. Process Development & Control, Inc.
 - l. Tyco Valves & Controls; a unit of Tyco Flow Control.
 - m. Xomox Corporation.

2. Description:

- a. Standard: MSS SP-68.
- b. CWP Rating: 285 psig at 100 deg F.
- c. Body Design: Lug type; suitable for bidirectional dead-end service at rated pressure without use of downstream flange.
- d. Body Material: Carbon steel or stainless steel.
- e. Seat: EPDM High Temperature or RTFE.
- f. Stem: 316 Stainless steel; offset from seat plane.
- g. Disc: 316 Stainless Steel.
- h. Service: Bidirectional.
- i. Hand wheel gear operated

C.

D. Class 300, Single-Flange, High-Performance Butterfly Valves:

1. Manufacturers: Subject to compliance with requirements, provide products by one of the following:

- a. ABZ Valve and Controls; a division of ABZ Manufacturing, Inc.
- b. Bray Controls; a division of Bray International.
- c. Cooper Cameron Valves; a division of Cooper Cameron Corp.
- d. Crane Co.; Crane Valve Group; Flowseal.
- e. Crane Co.; Crane Valve Group; Stockham Division.
- f. DeZurik Water Controls.
- g. Hammond Valve.
- h. Jamesbury; a subsidiary of Metso Automation.
- i. Milwaukee Valve Company.
- j. NIBCO INC.
- k. Process Development & Control, Inc.
- l. Tyco Valves & Controls; a unit of Tyco Flow Control.
- m. Xomox Corporation.

2. Description:

- a. Standard: MSS SP-68.
- b. CWP Rating: 720 psig at 100 deg F.
- c. Body Design: Lug type; suitable for bidirectional dead-end service at rated pressure without use of downstream flange.
- d. Body Material: Carbon steel or 316 Stainless Steel.
- e. Seat: EPDM High Temperature or RTFE.
- f. Stem: 316 Stainless steel; offset from seat plane.
- g. Disc: 316 Stainless Steel.
- h. Service: Bidirectional.
- i. Hand wheel gear operated

2.9 BUTTERFLY VALVES FOR BURIED CHILLED WATER, HEATING HOT WATER AND DOMESTIC WATER

- A. Provide Butterfly Valves with Mechanical Joints. Valves to include 150 PSIG seats, ANSI Class 150B bodies and 450 Ft-Lb Operator. Valves are to be closed Clockwise.

2.10 BRONZE LIFT CHECK VALVES

A. General Requirements:

1. NPS 2 and below provide 45° swing check with screwed ends for hydronic applications.
2. NPS 2-1/2 and above and over provide Non-slam type globe style lift check for hydronic applications.

B. Class 125, Lift Check Valves with Bronze Disc:

1. Manufacturers: Subject to compliance with requirements, provide products by one of the following:
 - a. Crane Co.; Crane Valve Group; Crane Valves.
 - b. Crane Co.; Crane Valve Group; Jenkins Valves.
 - c. Crane Co.; Crane Valve Group; Stockham Division.
2. Description:
 - a. Standard: MSS SP-80, Type 1.
 - b. CWP Rating: 200 psig.
 - c. Body Design: Vertical flow.
 - d. Body Material: ASTM B 61 or ASTM B 62, bronze.
 - e. Ends: Threaded.
 - f. Disc: Bronze.

C. Class 125, Lift Check Valves with Nonmetallic Disc:

1. Manufacturers: Subject to compliance with requirements, provide products by one of the following:
 - a. Flo Fab Inc.
 - b. Hammond Valve.
 - c. Kitz Corporation.
 - d. Milwaukee Valve Company.
 - e. Mueller Steam Specialty; a division of SPX Corporation.
 - f. NIBCO INC.
 - g. Red-White Valve Corporation.
 - h. Watts Regulator Co.; a division of Watts Water Technologies, Inc.
2. Description:

- a. Standard: MSS SP-80, Type 2.
- b. CWP Rating: 200 psig.
- c. Body Design: Vertical flow.
- d. Body Material: ASTM B 61 or ASTM B 62, bronze.
- e. Ends: Threaded.
- f. Disc: NBR, PTFE, or TFE.

2.11 BRONZE SWING CHECK VALVES

A. General Requirements:

1. NPS 2 and below provide 45° swing check with screwed ends for hydronic applications.
2. NPS 2-1/2 and above and over provide Non-slam type globe style lift check for hydronic applications.

B. Class 125, Bronze Swing Check Valves with Bronze Disc:

1. Manufacturers: Subject to compliance with requirements, provide products by one of the following:
 - a. American Valve, Inc.
 - b. Crane Co.; Crane Valve Group; Crane Valves.
 - c. Crane Co.; Crane Valve Group; Jenkins Valves.
 - d. Crane Co.; Crane Valve Group; Stockham Division.
 - e. Hammond Valve.
 - f. Kitz Corporation.
 - g. Milwaukee Valve Company.
 - h. NIBCO INC.
 - i. Powell Valves.
 - j. Red-White Valve Corporation.
 - k. Watts Regulator Co.; a division of Watts Water Technologies, Inc.
 - l. Zy-Tech Global Industries, Inc.
2. Description:
 - a. Standard: MSS SP-80, Type 3.
 - b. CWP Rating: 200 psig.
 - c. Body Design: Horizontal flow.
 - d. Body Material: ASTM B 62, bronze.
 - e. Ends: Threaded.
 - f. Disc: Bronze.

C. Class 125, Bronze Swing Check Valves with Nonmetallic Disc:

1. Manufacturers: Subject to compliance with requirements, provide products by one of the following:
 - a. Crane Co.; Crane Valve Group; Crane Valves.

- b. Crane Co.; Crane Valve Group; Jenkins Valves.
- c. Crane Co.; Crane Valve Group; Stockham Division.
- d. Hammond Valve.
- e. Kitz Corporation.
- f. Milwaukee Valve Company.
- g. NIBCO INC.
- h. Red-White Valve Corporation.
- i. Watts Regulator Co.; a division of Watts Water Technologies, Inc.

2. Description:

- a. Standard: MSS SP-80, Type 4.
- b. CWP Rating: 200 psig.
- c. Body Design: Horizontal flow.
- d. Body Material: ASTM B 62, bronze.
- e. Ends: Threaded.
- f. Disc: PTFE or TFE.

D. Class 150, Bronze Swing Check Valves with Bronze Disc:

1. Manufacturers: Subject to compliance with requirements, provide products by one of the following:

- a. American Valve, Inc.
- b. Crane Co.; Crane Valve Group; Crane Valves.
- c. Crane Co.; Crane Valve Group; Jenkins Valves.
- d. Crane Co.; Crane Valve Group; Stockham Division.
- e. Kitz Corporation.
- f. Milwaukee Valve Company.
- g. NIBCO INC.
- h. Red-White Valve Corporation.
- i. Zy-Tech Global Industries, Inc.

2. Description:

- a. Standard: MSS SP-80, Type 3.
- b. CWP Rating: 300 psig.
- c. Body Design: Horizontal flow.
- d. Body Material: ASTM B 62, bronze.
- e. Ends: Threaded.
- f. Disc: Bronze.

E. Class 150, Bronze Swing Check Valves with Nonmetallic Disc:

1. Manufacturers: Subject to compliance with requirements, provide products by one of the following:

- a. Crane Co.; Crane Valve Group; Crane Valves.
- b. Crane Co.; Crane Valve Group; Jenkins Valves.
- c. Hammond Valve.

- d. Milwaukee Valve Company.
- e. NIBCO INC.
- f. Watts Regulator Co.; a division of Watts Water Technologies, Inc.

2. Description:

- a. Standard: MSS SP-80, Type 4.
- b. CWP Rating: 300 psig.
- c. Body Design: Horizontal flow.
- d. Body Material: ASTM B 62, bronze.
- e. Ends: Threaded.
- f. Disc: PTFE or TFE.

2.12 IRON SWING CHECK VALVES

A. General Requirements:

- 1. NPS 2 and below provide 45° swing check with screwed ends for hydronic applications.
- 2. NPS 2-1/2 and above and over provide Non-slam type globe style lift check for hydronic applications.

B. Class 125, Iron Swing Check Valves with Metal Seats:

- 1. Manufacturers: Subject to compliance with requirements, provide products by one of the following:
 - a. Crane Co.; Crane Valve Group; Crane Valves.
 - b. Crane Co.; Crane Valve Group; Jenkins Valves.
 - c. Crane Co.; Crane Valve Group; Stockham Division.
 - d. Hammond Valve.
 - e. Kitz Corporation.
 - f. Legend Valve.
 - g. Milwaukee Valve Company.
 - h. NIBCO INC.
 - i. Powell Valves.
 - j. Red-White Valve Corporation.
 - k. Sure Flow Equipment Inc.
 - l. Watts Regulator Co.; a division of Watts Water Technologies, Inc.
 - m. Zy-Tech Global Industries, Inc.

2. Description:

- a. Standard: MSS SP-71, Type I.
- b. NPS 2-1/2 to NPS 12, CWP Rating: 200 psig.
- c. NPS 14 to NPS 24, CWP Rating: 150 psig.
- d. Body Design: Clear or full waterway.
- e. Body Material: ASTM A 126, gray iron with bolted bonnet.
- f. Ends: Flanged.

- g. Trim: Bronze.
- h. Gasket: Asbestos free.

C. Class 125, Iron Swing Check Valves with Nonmetallic-to-Metal Seats:

1. Manufacturers: Subject to compliance with requirements, provide products by one of the following:
 - a. Crane Co.; Crane Valve Group; Crane Valves.
 - b. Crane Co.; Crane Valve Group; Stockham Division.
2. Description:
 - a. Standard: MSS SP-71, Type I.
 - b. NPS 2-1/2 to NPS 12, CWP Rating: 200 psig.
 - c. NPS 14 to NPS 24, CWP Rating: 150 psig.
 - d. Body Design: Clear or full waterway.
 - e. Body Material: ASTM A 126, gray iron with bolted bonnet.
 - f. Ends: Flanged.
 - g. Trim: Composition.
 - h. Seat Ring: Bronze.
 - i. Disc Holder: Bronze.
 - j. Disc: PTFE or TFE.
 - k. Gasket: Asbestos free.

D. Class 250, Iron Swing Check Valves with Metal Seats:

1. Manufacturers: Subject to compliance with requirements, provide products by one of the following:
 - a. Crane Co.; Crane Valve Group; Crane Valves.
 - b. Crane Co.; Crane Valve Group; Jenkins Valves.
 - c. Crane Co.; Crane Valve Group; Stockham Division.
 - d. Hammond Valve.
 - e. Milwaukee Valve Company.
 - f. NIBCO INC.
 - g. Watts Regulator Co.; a division of Watts Water Technologies, Inc.
2. Description:
 - a. Standard: MSS SP-71, Type I.
 - b. NPS 2-1/2 to NPS 12, CWP Rating: 500 psig.
 - c. NPS 14 to NPS 24, CWP Rating: 300 psig.
 - d. Body Design: Clear or full waterway.
 - e. Body Material: ASTM A 126, gray iron with bolted bonnet.
 - f. Ends: Flanged.
 - g. Trim: Bronze.
 - h. Gasket: Asbestos free.

2.13 IRON, GROOVED-END SWING CHECK VALVES

A. General Requirements:

1. NPS 2 and below provide 45° swing check with screwed ends for hydronic applications.
2. NPS 2-1/2 and above and over provide Non-slam type globe style lift check for hydronic applications.

B. 300 CWP, Iron, Grooved-End Swing Check Valves:

1. Manufacturers: Subject to compliance with requirements, provide products by one of the following:
 - a. Anvil International, Inc.
 - b. Shurjoint Piping Products.
 - c. Tyco Fire Products LP; Grinnell Mechanical Products.
 - d. Victaulic Company.
2. Description:
 - a. CWP Rating: 300 psig.
 - b. Body Material: ASTM A 536, ductile iron.
 - c. Seal: EPDM.
 - d. Disc: Spring operated, ductile iron or stainless steel.

2.14 IRON, CENTER-GUIDED CHECK VALVES

A. General Requirements:

1. NPS 2 and below provide 45° swing check with screwed ends for hydronic applications.
2. NPS 2-1/2 and above and over provide Non-slam type globe style lift check for hydronic applications.

B. Class 125, Iron, Compact-Wafer, Center-Guided Check Valves with Metal Seat:

1. Manufacturers: Subject to compliance with requirements, provide products by one of the following:
 - a. Anvil International, Inc.
 - b. APCO Willamette Valve and Primer Corporation.
 - c. Crispin Valve.
 - d. DFT Inc.
 - e. Flo Fab Inc.
 - f. GA Industries, Inc.
 - g. Hammond Valve.
 - h. Metraflex, Inc.
 - i. Milwaukee Valve Company.

- j. Mueller Steam Specialty; a division of SPX Corporation.
- k. NIBCO INC.
- l. Spence Strainers International; a division of CIRCOR International.
- m. Sure Flow Equipment Inc.
- n. Val-Matic Valve & Manufacturing Corp.
- o. Watts Regulator Co.; a division of Watts Water Technologies, Inc.

2. Description:

- a. Standard: MSS SP-125.
- b. NPS 2-1/2 to NPS 12, CWP Rating: 200 psig.
- c. NPS 14 to NPS 24, CWP Rating: 150 psig.
- d. Body Material: ASTM A 126, gray iron.
- e. Style: Compact wafer.
- f. Seat: Bronze.

C. Class 125, Iron, Globe, Center-Guided Check Valves with Metal Seat:

1. Manufacturers: Subject to compliance with requirements, provide products by one of the following:

- a. APCO Willamette Valve and Primer Corporation.
- b. Crispin Valve.
- c. DFT Inc.
- d. Flomatic Corporation.
- e. Hammond Valve.
- f. Metraflex, Inc.
- g. Milwaukee Valve Company.
- h. Mueller Steam Specialty; a division of SPX Corporation.
- i. NIBCO INC.
- j. Spence Strainers International; a division of CIRCOR International.
- k. Sure Flow Equipment Inc.
- l. Val-Matic Valve & Manufacturing Corp.
- m. Watts Regulator Co.; a division of Watts Water Technologies, Inc.

2. Description:

- a. Standard: MSS SP-125.
- b. NPS 2-1/2 to NPS 12, CWP Rating: 200 psig.
- c. NPS 14 to NPS 24, CWP Rating: 150 psig.
- d. Body Material: ASTM A 126, gray iron.
- e. Style: Globe, spring loaded.
- f. Ends: Flanged.
- g. Seat: Bronze.

D. Class 150, Iron, Globe, Center-Guided Check Valves with Metal Seat:

1. Manufacturers: Subject to compliance with requirements, provide products by one of the following:

- a. APCO Willamette Valve and Primer Corporation.
 - b. Crispin Valve.
 - c. Val-Matic Valve & Manufacturing Corp.
2. Description:
- a. Standard: MSS SP-125.
 - b. NPS 2-1/2 to NPS 12, CWP Rating: 300 psig.
 - c. NPS 14 to NPS 24, CWP Rating: 250 psig.
 - d. Body Material: ASTM A 395/A 395M or ASTM A 536, ductile iron.
 - e. Style: Globe, spring loaded.
 - f. Ends: Flanged.
 - g. Seat: Bronze.
- E. Class 250, Iron, Globe, Center-Guided Check Valves with Metal Seat:
1. Manufacturers: Subject to compliance with requirements, provide products by one of the following:
 - a. APCO Willamette Valve and Primer Corporation.
 - b. Crispin Valve.
 - c. DFT Inc.
 - d. Flomatic Corporation.
 - e. Hammond Valve.
 - f. Metraflex, Inc.
 - g. Milwaukee Valve Company.
 - h. Mueller Steam Specialty; a division of SPX Corporation.
 - i. NIBCO INC.
 - j. Val-Matic Valve & Manufacturing Corp.
 2. Description:
 - a. Standard: MSS SP-125.
 - b. NPS 2-1/2 to NPS 12, CWP Rating: 400 psig.
 - c. NPS 14 to NPS 24, CWP Rating: 300 psig.
 - d. Body Material: ASTM A 126, gray iron.
 - e. Style: Globe, spring loaded.
 - f. Ends: Flanged.
 - g. Seat: Bronze.
- F. Class 300, Iron, Globe, Center-Guided Check Valves with Metal Seat:
1. Manufacturers: Subject to compliance with requirements, provide products by one of the following:
 - a. APCO Willamette Valve and Primer Corporation.
 - b. Crispin Valve.
 - c. Val-Matic Valve & Manufacturing Corp.
 2. Description:

- a. Standard: MSS SP-125.
- b. NPS 2-1/2 to NPS 12, CWP Rating: 500 psig.
- c. NPS 14 to NPS 24, CWP Rating: 400 psig.
- d. Body Material: ASTM A 395/A 395M or ASTM A 536, ductile iron.
- e. Style: Globe, spring loaded.
- f. Ends: Flanged.
- g. Seat: Bronze.

G. Class 125, Iron, Globe, Center-Guided Check Valves with Resilient Seat:

1. Manufacturers: Subject to compliance with requirements, provide products by one of the following:
 - a. Anvil International, Inc.
 - b. APCO Willamette Valve and Primer Corporation.
 - c. Crispin Valve.
 - d. DFT Inc.
 - e. GA Industries, Inc.
 - f. Hammond Valve.
 - g. Milwaukee Valve Company.
 - h. NIBCO INC.
 - i. Sure Flow Equipment Inc.
 - j. Val-Matic Valve & Manufacturing Corp.
2. Description:
 - a. Standard: MSS SP-125.
 - b. NPS 2-1/2 to NPS 12, CWP Rating: 200 psig.
 - c. NPS 14 to NPS 24, CWP Rating: 150 psig.
 - d. Body Material: ASTM A 126, gray iron.
 - e. Style: Globe, spring loaded.
 - f. Ends: Flanged.
 - g. Seat: EPDM.

H. Class 150, Iron, Globe, Center-Guided Check Valves with Resilient Seat:

1. Manufacturers: Subject to compliance with requirements, provide products by one of the following:
 - a. APCO Willamette Valve and Primer Corporation.
 - b. Crispin Valve.
 - c. DFT Inc.
 - d. Val-Matic Valve & Manufacturing Corp.
2. Description:
 - a. Standard: MSS SP-125.
 - b. NPS 2-1/2 to NPS 12, CWP Rating: 300 psig.
 - c. NPS 14 to NPS 24, CWP Rating: 250 psig.
 - d. Body Material: ASTM A 395/A 395M or ASTM A 536, ductile iron.

- e. Style: Globe, spring loaded.
- f. Ends: Flanged.
- g. Seat: EPDM.

I. Class 250, Iron, Globe, Center-Guided Check Valves with Resilient Seat:

- 1. Manufacturers: Subject to compliance with requirements, provide products by one of the following:
 - a. APCO Willamette Valve and Primer Corporation.
 - b. Crispin Valve.
 - c. DFT Inc.
 - d. Hammond Valve.
 - e. Milwaukee Valve Company.
 - f. NIBCO INC.
 - g. Val-Matic Valve & Manufacturing Corp.
- 2. Description:
 - a. Standard: MSS SP-125.
 - b. NPS 2-1/2 to NPS 12, CWP Rating: 400 psig.
 - c. NPS 14 to NPS 24, CWP Rating: 300 psig.
 - d. Body Material: ASTM A 126, gray iron.
 - e. Style: Globe, spring loaded.
 - f. Ends: Flanged.
 - g. Seat: EPDM.

J. Class 300, Iron, Globe, Center-Guided Check Valves with Resilient Seat:

- 1. Manufacturers: Subject to compliance with requirements, provide products by one of the following:
 - a. APCO Willamette Valve and Primer Corporation.
 - b. Crispin Valve.
 - c. Val-Matic Valve & Manufacturing Corp.
- 2. Description:
 - a. Standard: MSS SP-125.
 - b. NPS 2-1/2 to NPS 12, CWP Rating: 500 psig.
 - c. NPS 14 to NPS 24, CWP Rating: 400 psig.
 - d. Body Material: ASTM A 395/A 395M or ASTM A 536, ductile iron.
 - e. Style: Globe, spring loaded.
 - f. Ends: Flanged.
 - g. Seat: EPDM.

2.15 BRONZE GATE VALVES

A. Class 125, NRS Bronze Gate Valves:

1. Manufacturers: Subject to compliance with requirements, provide products by one of the following:
 - a. American Valve, Inc.
 - b. Crane Co.; Crane Valve Group; Crane Valves.
 - c. Crane Co.; Crane Valve Group; Jenkins Valves.
 - d. Crane Co.; Crane Valve Group; Stockham Division.
 - e. Hammond Valve.
 - f. Kitz Corporation.
 - g. Milwaukee Valve Company.
 - h. NIBCO INC.
 - i. Powell Valves.
 - j. Red-White Valve Corporation.
 - k. Watts Regulator Co.; a division of Watts Water Technologies, Inc.
 - l. Zy-Tech Global Industries, Inc.

2. Description:
 - a. Standard: MSS SP-80, Type 1.
 - b. CWP Rating: 200 psig.
 - c. Body Material: ASTM B 62, bronze with integral seat and screw-in bonnet.
 - d. Ends: Threaded or solder joint.
 - e. Stem: Bronze.
 - f. Disc: Solid wedge; bronze.
 - g. Packing: Asbestos free.
 - h. Handwheel: Malleable iron or aluminum.

B. Class 125, RS Bronze Gate Valves:

1. Manufacturers: Subject to compliance with requirements, provide products by one of the following:
 - a. American Valve, Inc.
 - b. Crane Co.; Crane Valve Group; Crane Valves.
 - c. Crane Co.; Crane Valve Group; Jenkins Valves.
 - d. Crane Co.; Crane Valve Group; Stockham Division.
 - e. Hammond Valve.
 - f. Kitz Corporation.
 - g. Milwaukee Valve Company.
 - h. NIBCO INC.
 - i. Powell Valves.
 - j. Watts Regulator Co.; a division of Watts Water Technologies, Inc.
 - k. Zy-Tech Global Industries, Inc.

2. Description:
 - a. Standard: MSS SP-80, Type 2.
 - b. CWP Rating: 200 psig.
 - c. Body Material: ASTM B 62, bronze with integral seat and screw-in bonnet.
 - d. Ends: Threaded.

- e. Stem: Bronze.
- f. Disc: Solid wedge; bronze.
- g. Packing: Asbestos free.
- h. Handwheel: Malleable iron or aluminum.

C. Class 150, NRS Bronze Gate Valves:

1. Manufacturers: Subject to compliance with requirements, provide products by one of the following:
 - a. Hammond Valve.
 - b. Kitz Corporation.
 - c. Milwaukee Valve Company.
 - d. NIBCO INC.
 - e. Powell Valves.
 - f. Red-White Valve Corporation.
 - g. Watts Regulator Co.; a division of Watts Water Technologies, Inc.
2. Description:
 - a. Standard: MSS SP-80, Type 1.
 - b. CWP Rating: 300 psig.
 - c. Body Material: ASTM B 62, bronze with integral seat and union-ring bonnet.
 - d. Ends: Threaded.
 - e. Stem: Bronze.
 - f. Disc: Solid wedge; bronze.
 - g. Packing: Asbestos free.
 - h. Handwheel: Malleable iron or aluminum.

D. Class 150, RS Bronze Gate Valves:

1. Manufacturers: Subject to compliance with requirements, provide products by one of the following:
 - a. Crane Co.; Crane Valve Group; Crane Valves.
 - b. Crane Co.; Crane Valve Group; Stockham Division.
 - c. Hammond Valve.
 - d. Kitz Corporation.
 - e. Milwaukee Valve Company.
 - f. NIBCO INC.
 - g. Powell Valves.
 - h. Watts Regulator Co.; a division of Watts Water Technologies, Inc.
 - i. Zy-Tech Global Industries, Inc.
2. Description:
 - a. Standard: MSS SP-80, Type 2.
 - b. CWP Rating: 300 psig.
 - c. Body Material: ASTM B 62, bronze with integral seat and union-ring bonnet.
 - d. Ends: Threaded.

- e. Stem: Bronze.
- f. Disc: Solid wedge; bronze.
- g. Packing: Asbestos free.
- h. Handwheel: Malleable iron or aluminum.

2.16 IRON GATE VALVES

A. Class 125, NRS, Iron Gate Valves:

1. Manufacturers: Subject to compliance with requirements, provide products by one of the following:
 - a. Crane Co.; Crane Valve Group; Crane Valves.
 - b. Crane Co.; Crane Valve Group; Jenkins Valves.
 - c. Crane Co.; Crane Valve Group; Stockham Division.
 - d. Flo Fab Inc.
 - e. Hammond Valve.
 - f. Kitz Corporation.
 - g. Legend Valve.
 - h. Milwaukee Valve Company.
 - i. NIBCO INC.
 - j. Powell Valves.
 - k. Red-White Valve Corporation.
 - l. Watts Regulator Co.; a division of Watts Water Technologies, Inc.
 - m. Zy-Tech Global Industries, Inc.
2. Description:
 - a. Standard: MSS SP-70, Type I.
 - b. NPS 2-1/2 to NPS 12, CWP Rating: 200 psig.
 - c. NPS 14 to NPS 24, CWP Rating: 150 psig.
 - d. Body Material: ASTM A 126, gray iron with bolted bonnet.
 - e. Ends: Flanged.
 - f. Trim: Bronze.
 - g. Disc: Solid wedge.
 - h. Packing and Gasket: Asbestos free.

B. Class 125, OS&Y, Iron Gate Valves:

1. Manufacturers: Subject to compliance with requirements, provide products by one of the following:
 - a. Crane Co.; Crane Valve Group; Crane Valves.
 - b. Crane Co.; Crane Valve Group; Jenkins Valves.
 - c. Crane Co.; Crane Valve Group; Stockham Division.
 - d. Flo Fab Inc.
 - e. Hammond Valve.
 - f. Kitz Corporation.
 - g. Legend Valve.

- h. Milwaukee Valve Company.
- i. NIBCO INC.
- j. Powell Valves.
- k. Red-White Valve Corporation.
- l. Watts Regulator Co.; a division of Watts Water Technologies, Inc.
- m. Zy-Tech Global Industries, Inc.

2. Description:

- a. Standard: MSS SP-70, Type I.
- b. NPS 2-1/2 to NPS 12, CWP Rating: 200 psig.
- c. NPS 14 to NPS 24, CWP Rating: 150 psig.
- d. Body Material: ASTM A 126, gray iron with bolted bonnet.
- e. Ends: Flanged.
- f. Trim: Bronze.
- g. Disc: Solid wedge.
- h. Packing and Gasket: Asbestos free.

C. Class 250, NRS, Iron Gate Valves:

1. Manufacturers: Subject to compliance with requirements, provide products by one of the following:

- a. Crane Co.; Crane Valve Group; Crane Valves.
- b. Crane Co.; Crane Valve Group; Stockham Division.
- c. NIBCO INC.

2. Description:

- a. Standard: MSS SP-70, Type I.
- b. NPS 2-1/2 to NPS 12, CWP Rating: 500 psig.
- c. NPS 14 to NPS 24, CWP Rating: 300 psig.
- d. Body Material: ASTM A 126, gray iron with bolted bonnet.
- e. Ends: Flanged.
- f. Trim: Bronze.
- g. Disc: Solid wedge.
- h. Packing and Gasket: Asbestos free.

D. Class 250, OS&Y, Iron Gate Valves:

1. Manufacturers: Subject to compliance with requirements, provide products by one of the following:

- a. Crane Co.; Crane Valve Group; Crane Valves.
- b. Crane Co.; Crane Valve Group; Stockham Division.
- c. Hammond Valve.
- d. Milwaukee Valve Company.
- e. NIBCO INC.
- f. Powell Valves.

- g. Watts Regulator Co.; a division of Watts Water Technologies, Inc.

2. Description:

- a. Standard: MSS SP-70, Type I.
- b. NPS 2-1/2 to NPS 12, CWP Rating: 500 psig.
- c. NPS 14 to NPS 24, CWP Rating: 300 psig.
- d. Body Material: ASTM A 126, gray iron with bolted bonnet.
- e. Ends: Flanged.
- f. Trim: Bronze.
- g. Disc: Solid wedge.
- h. Packing and Gasket: Asbestos free.

2.17 BRONZE GLOBE VALVES

A. Class 125, Bronze Globe Valves with Bronze Disc:

1. Manufacturers: Subject to compliance with requirements, provide products by one of the following:

- a. Crane Co.; Crane Valve Group; Crane Valves.
- b. Crane Co.; Crane Valve Group; Stockham Division.
- c. Hammond Valve.
- d. Kitz Corporation.
- e. Milwaukee Valve Company.
- f. NIBCO INC.
- g. Powell Valves.
- h. Red-White Valve Corporation.
- i. Watts Regulator Co.; a division of Watts Water Technologies, Inc.
- j. Zy-Tech Global Industries, Inc.

2. Description:

- a. Standard: MSS SP-80, Type 1.
- b. CWP Rating: 200 psig.
- c. Body Material: ASTM B 62, bronze with integral seat and screw-in bonnet.
- d. Ends: Threaded.
- e. Stem and Disc: Bronze.
- f. Packing: Asbestos free.
- g. Handwheel: Malleable iron or aluminum.

B. Class 125, Bronze Globe Valves with Nonmetallic Disc:

1. Manufacturers: Subject to compliance with requirements, provide products by one of the following:

- a. Crane Co.; Crane Valve Group; Crane Valves.
- b. Crane Co.; Crane Valve Group; Stockham Division.
- c. NIBCO INC.

- d. Red-White Valve Corporation.
- 2. Description:
 - a. Standard: MSS SP-80, Type 2.
 - b. CWP Rating: 200 psig.
 - c. Body Material: ASTM B 62, bronze with integral seat and screw-in bonnet.
 - d. Ends: Threaded.
 - e. Stem: Bronze.
 - f. Disc: PTFE or TFE.
 - g. Packing: Asbestos free.
 - h. Handwheel: Malleable iron or aluminum.
- C. Class 150, Bronze Globe Valves with Nonmetallic Disc:
 - 1. Manufacturers: Subject to compliance with requirements, provide products by one of the following:
 - a. Crane Co.; Crane Valve Group; Crane Valves.
 - b. Hammond Valve.
 - c. Kitz Corporation.
 - d. Milwaukee Valve Company.
 - e. NIBCO INC.
 - f. Powell Valves.
 - g. Red-White Valve Corporation.
 - h. Watts Regulator Co.; a division of Watts Water Technologies, Inc.
 - i. Zy-Tech Global Industries, Inc.
 - 2. Description:
 - a. Standard: MSS SP-80, Type 2.
 - b. CWP Rating: 300 psig.
 - c. Body Material: ASTM B 62, bronze with integral seat and union-ring bonnet.
 - d. Ends: Threaded.
 - e. Stem: Bronze.
 - f. Disc: PTFE or TFE.
 - g. Packing: Asbestos free.
 - h. Handwheel: Malleable iron or aluminum.

2.18 IRON GLOBE VALVES

- A. Class 125, Iron Globe Valves:
 - 1. Manufacturers: Subject to compliance with requirements, provide products by one of the following:
 - a. Crane Co.; Crane Valve Group; Crane Valves.
 - b. Crane Co.; Crane Valve Group; Jenkins Valves.
 - c. Crane Co.; Crane Valve Group; Stockham Division.

- d. Hammond Valve.
- e. Kitz Corporation.
- f. Milwaukee Valve Company.
- g. NIBCO INC.
- h. Powell Valves.
- i. Red-White Valve Corporation.
- j. Watts Regulator Co.; a division of Watts Water Technologies, Inc.
- k. Zy-Tech Global Industries, Inc.

2. Description:

- a. Standard: MSS SP-85, Type I.
- b. CWP Rating: 200 psig.
- c. Body Material: ASTM A 126, gray iron with bolted bonnet.
- d. Ends: Flanged.
- e. Trim: Bronze.
- f. Packing and Gasket: Asbestos free.

B. Class 250, Iron Globe Valves:

1. Manufacturers: Subject to compliance with requirements, provide products by one of the following:

- a. Crane Co.; Crane Valve Group; Crane Valves.
- b. Crane Co.; Crane Valve Group; Jenkins Valves.
- c. Crane Co.; Crane Valve Group; Stockham Division.
- d. Hammond Valve.
- e. Milwaukee Valve Company.
- f. NIBCO INC.
- g. Watts Regulator Co.; a division of Watts Water Technologies, Inc.

2. Description:

- a. Standard: MSS SP-85, Type I.
- b. CWP Rating: 500 psig.
- c. Body Material: ASTM A 126, gray iron with bolted bonnet.
- d. Ends: Flanged.
- e. Trim: Bronze.
- f. Packing and Gasket: Asbestos free.

2.19 LUBRICATED PLUG VALVES

A. Class 125, Regular-Gland, Lubricated Plug Valves with Threaded Ends:

1. Manufacturers: Subject to compliance with requirements, provide products by one of the following:

- a. Nordstrom Valves, Inc.

2. Description:

- a. Standard: MSS SP-78, Type II.
- b. NPS 2-1/2 to NPS 12, CWP Rating: 200 psig.
- c. NPS 14 to NPS 24, CWP Rating: 150 psig.
- d. Body Material: ASTM A 48/A 48M or ASTM A 126, cast iron with lubrication-sealing system.
- e. Pattern: Regular or short.
- f. Plug: Cast iron or bronze with sealant groove.

B. Class 125, Regular-Gland, Lubricated Plug Valves with Flanged Ends:

1. Manufacturers: Subject to compliance with requirements, provide products by one of the following:

- a. Nordstrom Valves, Inc.

2. Description:

- a. Standard: MSS SP-78, Type II.
- b. NPS 2-1/2 to NPS 12, CWP Rating: 200 psig.
- c. NPS 14 to NPS 24, CWP Rating: 150 psig.
- d. Body Material: ASTM A 48/A 48M or ASTM A 126, cast iron with lubrication-sealing system.
- e. Pattern: Regular or short.
- f. Plug: Cast iron or bronze with sealant groove.

C. Class 250, Regular-Gland, Lubricated Plug Valves with Threaded Ends:

1. Manufacturers: Subject to compliance with requirements, provide products by one of the following:

- a. Nordstrom Valves, Inc.

2. Description:

- a. Standard: MSS SP-78, Type II.
- b. NPS 2-1/2 to NPS 12, CWP Rating: 400 psig.
- c. NPS 14 to NPS 24, CWP Rating: 300 psig.
- d. Body Material: ASTM A 48/A 48M or ASTM A 126, cast iron with lubrication-sealing system.
- e. Pattern: Regular or short.
- f. Plug: Cast iron or bronze with sealant groove.

D. Class 250, Regular-Gland, Lubricated Plug Valves with Flanged Ends:

1. Manufacturers: Subject to compliance with requirements, provide products by one of the following:

- a. Nordstrom Valves, Inc.

2. Description:
 - a. Standard: MSS SP-78, Type II.
 - b. NPS 2-1/2 to NPS 12, CWP Rating: 400 psig.
 - c. NPS 14 to NPS 24, CWP Rating: 300 psig.
 - d. Body Material: ASTM A 48/A 48M or ASTM A 126, cast iron with lubrication-sealing system.
 - e. Pattern: Regular or short.
 - f. Plug: Cast iron or bronze with sealant groove.

E. Class 250, Cylindrical, Lubricated Plug Valves with Threaded Ends:

1. Manufacturers: Subject to compliance with requirements, provide products by one of the following:
 - a. Homestead Valve; a division of Olson Technologies, Inc.
 - b. Milliken Valve Company.
 - c. R & M Energy Systems; a unit of Robbins & Myers, Inc.
2. Description:
 - a. Standard: MSS SP-78, Type IV.
 - b. NPS 2-1/2 to NPS 12, CWP Rating: 400 psig.
 - c. NPS 14 to NPS 24, CWP Rating: 300 psig.
 - d. Body Material: ASTM A 48/A 48M or ASTM A 126, cast iron with lubrication-sealing system.
 - e. Pattern: Regular or short.
 - f. Plug: Cast iron or bronze with sealant groove.

2.20 ECCENTRIC PLUG VALVES

A. 175 CWP, Eccentric Plug Valves with Resilient Seating.

1. Manufacturers: Subject to compliance with requirements, provide products by one of the following:
 - a. Clow Valve Co.; a division of McWane, Inc.
 - b. DeZurik Water Controls.
 - c. Homestead Valve; a division of Olson Technologies, Inc.
 - d. M&H Valve Company; a division of McWane, Inc.
 - e. Milliken Valve Company.
 - f. Henry Pratt Company.
 - g. Val-Matic Valve & Manufacturing Corp.
2. Description:
 - a. Standard: MSS SP-108.
 - b. CWP Rating: 175 psig minimum.

- c. Body and Plug: ASTM A 48/A 48M, gray iron; ASTM A 126, gray iron; or ASTM A 536, ductile iron.
- d. Bearings: Oil-impregnated bronze or stainless steel.
- e. Ends: Flanged.
- f. Stem-Seal Packing: Asbestos free.
- g. Plug, Resilient-Seating Material: Suitable for potable-water service unless otherwise indicated.

2.21 CHAINWHEELS

- A. Manufacturers: Subject to compliance with requirements, provide products by one of the following:
 - 1. Babbitt Steam Specialty Co.
 - 2. Roto Hammer Industries.
 - 3. Trumbull Industries.
- B. Description: Valve actuation assembly with sprocket rim, brackets, and chain.
 - 1. Brackets: Type, number, size, and fasteners required to mount actuator on valve.
 - 2. Attachment: For connection to butterfly valve stems.
 - 3. Sprocket Rim with Chain Guides: Ductile or cast iron, of type and size required for valve. Include zinc coating.
 - 4. Chain: Hot-dip, galvanized steel, of size required to fit sprocket rim.

PART 3 - EXECUTION

3.1 EXAMINATION

- A. Examine valve interior for cleanliness, freedom from foreign matter, and corrosion. Remove special packing materials, such as blocks, used to prevent disc movement during shipping and handling.
- B. Operate valves in positions from fully open to fully closed. Examine guides and seats made accessible by such operations.
- C. Examine threads on valve and mating pipe for form and cleanliness.
- D. Examine mating flange faces for conditions that might cause leakage. Check bolting for proper size, length, and material. Verify that gasket is of proper size, that its material composition is suitable for service, and that it is free from defects and damage.
- E. Do not attempt to repair defective valves; replace with new valves.

3.2 VALVE INSTALLATION

- A. Install valves with unions or flanges at each piece of equipment arranged to allow service, maintenance, and equipment removal without system shutdown.
- B. Locate valves for easy access and provide separate support where necessary.
- C. Install valves in horizontal piping with stem at or above center of pipe.
- D. Install valves in position to allow full stem movement. For valves installed on insulated piping handle stems shall be extended the insulation jacket by a minimum of 1". For Chilled Water systems, Valve extensions are to be non-conductive type, or be provided with plastic cup that allows for continuous insulation vapor barrier.
- E. Install chainwheels on operators for butterfly gate valves NPS 4 and larger and more than 96 inches above floor. Extend chains to 60 inches above finished floor.
- F. Install check valves for proper direction of flow and as follows:
 - 1. Swing Check Valves: In horizontal position with hinge pin level.
 - 2. Center-Guided Check Valves: In horizontal or vertical position, between flanges.
 - 3. Lift Check Valves: With stem upright and plumb.
- G. Buried Chilled Water, Heating Hot Water or Domestic Water valves are to be as specified:
 - 1. Buried butterfly valves on Chilled Water, Heating Hot Water or Domestic water systems are to be installed in underground systems and shall have as an enclosure a concrete valve box with sufficient space to replace valve and operate gear.

3.3 ADJUSTING

- A. Adjust or replace valve packing after piping systems have been tested and put into service but before final adjusting and balancing. Replace valves if persistent leaking occurs.

3.4 GENERAL REQUIREMENTS FOR VALVE APPLICATIONS

- A. If valve applications are not indicated, use the following:
 - 1. Shutoff Service: Ball or butterfly valves.
 - 2. Butterfly Valve Dead-End Service: Single-flange (lug) type.
 - 3. Throttling Service except Steam: Globe or angle valves.
 - 4. Throttling Service, Steam: Globe or angle valves.
 - 5. Pump-Discharge Check Valves:
 - a. NPS 2 and Smaller: Bronze swing check valves with bronze disc.
 - b. NPS 2-1/2 and Larger: Iron swing check valves with lever and weight or with spring or iron, center-guided, resilient-seat check valves.

- B. If valves with specified SWP classes or CWP ratings are not available, the same types of valves with higher SWP classes or CWP ratings may be substituted.
- C. Select valves, except wafer types, with the following end connections:
 - 1. For Copper Tubing, NPS 2 and Smaller: Threaded ends except where solder-joint valve-end option is indicated in valve schedules below.
 - 2. For Copper Tubing, NPS 2-1/2 to NPS 4: Flanged ends except where threaded valve-end option is indicated in valve schedules below.
 - 3. For Copper Tubing, NPS 5 and Larger: Flanged ends.
 - 4. For Steel Piping, NPS 2 and Smaller: Threaded ends.
 - 5. For Steel Piping, NPS 2-1/2 to NPS 4: Flanged ends except where threaded valve-end option is indicated in valve schedules below.
 - 6. For Steel Piping, NPS 5 and Larger: Flanged ends.
 - 7. For Grooved-End Copper Tubing except Steam and Steam Condensate Piping: Valve ends may be grooved.

3.5 CHILLED-WATER VALVE SCHEDULE

- A. Pipe NPS 2 and Smaller:
 - 1. Bronze Valves: May be provided with solder-joint ends instead of threaded ends.
 - 2. Bronze Angle Valves: Class 125, bronze disc.
 - 3. Ball Valves: Three piece, full port, bronze with stainless-steel trim.
 - 4. Bronze Swing Check Valves: Class 125, bronze disc.
 - 5. Bronze Gate Valves: Class 125, NRS, bronze.
 - 6. Bronze Globe Valves: Class 125, bronze disc.
- B. Pipe NPS 2-1/2 and Larger:
 - 1. Iron Valves, NPS 2-1/2 to NPS 4: May be provided with threaded ends instead of flanged ends.
 - 2. Iron Ball Valves, NPS 2-1/2 to NPS 10: Class 150.
 - 3. Iron, Single-Flange Butterfly Valves, NPS 2-1/2 to NPS 12: 200 CWP, EPDM seat, aluminum-bronze disc.
 - 4. Iron, Single-Flange Butterfly Valves, NPS 14 to NPS 24: 150 CWP, EPDM seat, aluminum-bronze.
 - 5. Iron, Grooved-End Butterfly Valves, NPS 2-1/2 to NPS 12: 175 CWP.
 - 6. High-Performance Butterfly Valves: Class 150, single flange.
 - 7. Iron Swing Check Valves: Class 125, nonmetallic-to-metal seats.
 - 8. Iron Swing Check Valves with Closure Control, NPS 2-1/2 to NPS 12: Class 125, lever and spring.
 - 9. Iron Gate Valves: Class 125, OS&Y.
 - 10. Iron Globe Valves: Class 125.
 - 11. Lubricated Plug Valves: Class 125, regular gland.
 - 12. Eccentric Plug Valves: 175 CWP, resilient seating.

3.6 CONDENSER-WATER VALVE SCHEDULE

A. Pipe NPS 2 and Smaller:

1. Bronze Valves: May be provided with solder-joint ends instead of threaded ends.
2. Bronze Angle Valves: Class 125, bronze disc.
3. Ball Valves: Three piece, full port, bronze with stainless-steel trim.
4. Bronze Swing Check Valves: Class 125, bronze disc.
5. Bronze Gate Valves: Class 125, NRS.
6. Bronze Globe Valves: Class 125, bronze disc.

B. Pipe NPS 2-1/2 and Larger:

1. Iron Valves, NPS 2-1/2 to NPS 4: May be provided with threaded ends instead of flanged ends.
2. Iron Ball Valves, NPS 2-1/2 to NPS 10: Class 150.
3. Iron, Single-Flange Butterfly Valves, NPS 2-1/2 to NPS 12: 200 CWP, EPDM seat, aluminum-bronze disc.
4. Iron, Single-Flange Butterfly Valves, NPS 14 to NPS 24: 150 CWP, EPDM seat, aluminum-bronze disc.
5. Iron, Grooved-End Butterfly Valves, NPS 2-1/2 to NPS 12: 175 CWP.
6. High-Performance Butterfly Valves: Class 150, single flange.
7. Iron Swing Check Valves: Class 125, nonmetallic-to-metal seats.
8. Iron Swing Check Valves with Closure Control, NPS 2-1/2 to NPS 12: Class 125, lever and spring.
9. Iron, Grooved-End Check Valves, NPS 3 to NPS 12: 300 CWP.
10. Iron, Center-Guided Check Valves, NPS 2-1/2 to NPS 24: Class 125, resilient seat.
11. Iron Gate Valves: Class 125, OS&Y.
12. Iron Globe Valves, NPS 2-1/2 to NPS 12: Class 125.
13. Lubricated Plug Valves: Class 125, regular gland.

3.7 HEATING-WATER VALVE SCHEDULE

A. Pipe NPS 2 and Smaller:

1. Bronze Valves: May be provided with solder-joint ends instead of threaded ends.
2. Bronze Angle Valves: Class 125, bronze disc.
3. Ball Valves: Three piece, full port, bronze with stainless-steel trim.
4. Bronze Swing Check Valves: Class 125, bronze disc.
5. Bronze Gate Valves: Class 125, NRS.
6. Bronze Globe Valves: Class 125, nonmetallic disc.

B. Pipe NPS 2-1/2 and Larger:

1. Iron Valves, NPS 2-1/2 to NPS 4: May be provided with threaded ends instead of flanged ends.
2. Iron Ball Valves, NPS 2-1/2 to NPS 10: Class 150.
3. Iron, Single-Flange Butterfly Valves, NPS 2-1/2 to NPS 12: 200 CWP, EPDM seat, aluminum-bronze disc.

4. Iron, Single-Flange Butterfly Valves, NPS 14 to NPS 24: 150 CWP, EPDM seat, aluminum-bronze disc.
5. Iron, Grooved-End Butterfly Valves, NPS 2-1/2 to NPS 12: 175 CWP.
6. High-Performance Butterfly Valves: Class 150, single flange.
7. Iron Swing Check Valves: Class 125, nonmetallic-to-metal seats.
8. Iron, Grooved-End Check Valves, NPS 3 to NPS 12: 300 CWP.
9. Iron Gate Valves: Class 125, OS&Y.
10. Iron Globe Valves, NPS 2-1/2 to NPS 12: Class 125.

3.8 LOW-PRESSURE STEAM VALVE SCHEDULE (15 PSIG OR LESS)

A. Pipe NPS 2 and Smaller:

1. Bronze Angle Valves: Class 125, bronze disc.
2. Ball Valves: Three piece, full port, bronze with bronze trim.
3. Bronze Swing Check Valves: Class 125, bronze disc.
4. Bronze Gate Valves: Class 125, NRS.
5. Bronze Globe Valves: Class 125, bronze disc.

B. Pipe NPS 2-1/2 and Larger:

1. Iron Valves, NPS 2-1/2 to NPS 4: May be provided with threaded ends instead of flanged ends.
2. Iron Ball Valves, NPS 2-1/2 to NPS 10: Class 150.
3. High-Performance Butterfly Valves: Class 150, single flange.
4. Iron Swing Check Valves: Class 125, nonmetallic-to-metal seats.
5. Iron Gate Valves: Class 125, OS&Y.
6. Iron Globe Valves, NPS 2-1/2 to NPS 12: Class 125.

3.9 HIGH-PRESSURE STEAM VALVE SCHEDULE (MORE THAN 15 PSIG)

A. Pipe NPS 2 and Smaller:

1. Bronze Angle Valves: Class 150, bronze disc.
2. Ball Valves: Three piece, full port, bronze with bronze trim.
3. Bronze Swing Check Valves: Class 150, bronze disc.
4. Bronze Gate Valves: Class 150, NRS, bronze.
5. Globe Valves: Class 150, bronze, disc.

B. Pipe Sizes NPS 2-1/2 and Larger:

1. Iron Valves, NPS 2-1/2 to NPS 4: May be provided with threaded ends instead of flanged ends.
2. Ball Valves, NPS 2-1/2 to NPS 10: Class 150, iron.
3. High-Performance Butterfly Valves: Class 150, single flange.
4. Iron Swing Check Valves: Class 250, nonmetallic-to-metal seats.
5. Iron Gate Valves: Class 250, OS&Y.
6. Iron Globe Valves, NPS 2-1/2 to NPS 12: Class 250.

3.10 STEAM-CONDENSATE VALVE SCHEDULE

A. Pipe NPS 2 and Smaller:

1. Bronze Angle Valves: Class 125, bronze disc.
2. Ball Valves: Three piece, full port, bronze with bronze trim.
3. Bronze Swing Check Valves: Class 125, bronze disc.
4. Bronze Gate Valves: Class 125, NRS.
5. Bronze Globe Valves: Class 125, bronze disc.

B. Pipe NPS 2-1/2 and Larger:

1. Iron Valves, NPS 2-1/2 to NPS 4: May be provided with threaded ends instead of flanged ends.
2. Iron Ball Valves, NPS 2-1/2 to NPS 10: Class 150.
3. High-Performance Butterfly Valves: Class 150, single flange.
4. Iron Swing Check Valves: Class 125, nonmetallic-to-metal seats.
5. Iron Gate Valves: Class 125, NRS.
6. Iron Globe Valves, NPS 2-1/2 to NPS 12: Class 125.
7. Lubricated Plug Valves: Class 125, regular gland, threaded.

END OF SECTION 230523

SECTION 230529 - HANGERS AND SUPPORTS FOR HVAC PIPING AND EQUIPMENT

PART 1 - GENERAL

1.1 RELATED DOCUMENTS

- A. Drawings and general provisions of the Contract, including General and Supplementary Conditions and Division 01 Specification Sections, apply to this Section.

1.2 SUMMARY

- A. Section Includes:

1. Metal pipe hangers and supports.
2. Trapeze pipe hangers.
3. Fiberglass pipe hangers.
4. Metal framing systems.
5. Fiberglass strut systems.
6. Thermal-hanger shield inserts.
7. Fastener systems.
8. Pipe stands.
9. Equipment supports.

- B. Related Sections:

1. Division 05 Section "Metal Fabrications" for structural-steel shapes and plates for trapeze hangers for pipe and equipment supports.
2. Division 23 Section "Vibration Controls for HVAC " for vibration isolation devices.
3. Division 23 Section "Metal Ducts" for duct hangers and supports.

1.3 DEFINITIONS

- A. MSS: Manufacturers Standardization Society of The Valve and Fittings Industry Inc.

1.4 PERFORMANCE REQUIREMENTS

- A. Delegated Design: Design trapeze pipe hangers and equipment supports, including comprehensive engineering analysis by a qualified professional engineer, using performance requirements and design criteria indicated.
- B. Structural Performance: Hangers and supports for HVAC piping and equipment shall withstand the effects of gravity loads and stresses within limits and under conditions indicated according to ASCE/SEI 7.
 - 1. Design supports for multiple pipes, including pipe stands, capable of supporting combined weight of supported systems, system contents, and test water.
 - 2. Design equipment supports capable of supporting combined operating weight of supported equipment and connected systems and components.
 - 3. Design seismic-restraint hangers and supports for piping and equipment and obtain approval from University of Maryland.

1.5 SUBMITTALS

- A. Product Data: For each type of product indicated.
- B. Shop Drawings: Signed and sealed by a qualified professional engineer. Show fabrication and installation details and include calculations for the following; include Product Data for components:
 - 1. Trapeze pipe hangers.
 - 2. Metal framing systems.
 - 3. Fiberglass strut systems.
 - 4. Pipe stands.
 - 5. Equipment supports.
- C. Delegated-Design Submittal: For trapeze hangers indicated to comply with performance requirements and design criteria, including analysis data signed and sealed by the qualified professional engineer responsible for their preparation.
 - 1. Detail fabrication and assembly of trapeze hangers.
 - 2. Design Calculations: Calculate requirements for designing trapeze hangers.
- D. Welding certificates.

1.6 QUALITY ASSURANCE

- A. Structural Steel Welding Qualifications: Qualify procedures and personnel according to AWS D1.1/D1.1M, "Structural Welding Code - Steel."
- B. Pipe Welding Qualifications: Qualify procedures and operators according to ASME Boiler and Pressure Vessel Code.

PART 2 - PRODUCTS

2.1 METAL PIPE HANGERS AND SUPPORTS

- A. Carbon-Steel Pipe Hangers and Supports:
 - 1. Description: MSS SP-58, Types 1 through 58, factory-fabricated components.
 - 2. Galvanized Metallic Coatings: Pregalvanized or hot dipped.
 - 3. Nonmetallic Coatings: Plastic coating, jacket, or liner.
 - 4. Padded Hangers: Hanger with fiberglass or other pipe insulation pad or cushion to support bearing surface of piping.
 - 5. Hanger Rods: Continuous-thread rod, nuts, and washer made of carbon steel.

2.2 TRAPEZE PIPE HANGERS

- A. Description: MSS SP-69, Type 59, shop- or field-fabricated pipe-support assembly made from structural carbon-steel shapes with MSS SP-58 carbon-steel hanger rods, nuts, saddles, and U-bolts.

2.3 FIBERGLASS PIPE HANGERS

- A. Clevis-Type, Fiberglass Pipe Hangers:
 - 1. Description: Similar to MSS SP-58, Type 1, steel pipe hanger except hanger is made of fiberglass or fiberglass-reinforced resin.
 - 2. Hanger Rods: Continuous-thread rod, washer, and nuts made of galvanized steel.
- B. Strap-Type, Fiberglass Pipe Hangers:
 - 1. Description: Similar to MSS SP-58, Type 9 or Type 10, steel pipe hanger except hanger is made of fiberglass-reinforced resin.

2. Hanger Rod and Fittings: Continuous-thread rod, washer, and nuts made of galvanized steel.

2.4 METAL FRAMING SYSTEMS

A. MFMA Manufacturer Metal Framing Systems:

1. Manufacturers: Subject to compliance with requirements, provide products by one of the following:
2. Basis-of-Design Product: Subject to compliance with requirements, provide product by one of the following:
 - a. Allied Tube & Conduit.
 - b. Cooper B-Line, Inc.
 - c. Flex-Strut Inc.
 - d. GS Metals Corp.
 - e. Thomas & Betts Corporation.
 - f. Unistrut Corporation; Tyco International, Ltd.
 - g. Wesanco, Inc.
3. Description: Shop- or field-fabricated pipe-support assembly for supporting multiple parallel pipes.
4. Standard: MFMA-4.
5. Channels: Continuous slotted steel channel with inturred lips.
6. Channel Nuts: Formed or stamped steel nuts or other devices designed to fit into channel slot and, when tightened, prevent slipping along channel.
7. Hanger Rods: Continuous-thread rod, nuts, and washer made of carbon steel.
8. Metallic Coating: Hot-dipped galvanized.
9. Paint Coating: Epoxy.
10. Plastic Coating: Polyurethane.

B. Non-MFMA Manufacturer Metal Framing Systems:

1. Basis-of-Design Product: Subject to compliance with requirements, provide by one of the following: Anvil International; a subsidiary of Mueller Water Products Inc.

- a. Empire Industries, Inc.
 - b. ERICO International Corporation.
 - c. Haydon Corporation; H-Strut Division.
 - d. NIBCO INC.
 - e. PHD Manufacturing, Inc.
 - f. PHS Industries, Inc.
2. Description: Shop- or field-fabricated pipe-support assembly made of steel channels, accessories, fittings, and other components for supporting multiple parallel pipes.
 3. Standard: Comply with MFMA-4.
 4. Channels: Continuous slotted steel channel with inturred lips.
 5. Channel Nuts: Formed or stamped steel nuts or other devices designed to fit into channel slot and, when tightened, prevent slipping along channel.
 6. Hanger Rods: Continuous-thread rod, nuts, and washer made of galvanized steel.

2.5 FIBERGLASS STRUT SYSTEMS

- A. Manufacturers: Subject to compliance with requirements, provide products by one of the following:
- B. Basis-of-Design Product: Subject to compliance with requirements, provide product by one of the following:
 1. Allied Tube & Conduit.
 2. Champion Fiberglass, Inc.
 3. Cooper B-Line, Inc.
 4. SEASAFE, INC.; a Gibraltar Industries Company.
- C. Description: Shop- or field-fabricated pipe-support assembly similar to MFMA-4 for supporting multiple parallel pipes.
 1. Channels: Continuous slotted fiberglass channel with inturred lips.
 2. Channel Nuts: Fiberglass nuts or other devices designed to fit into channel slot and, when tightened, prevent slipping along channel.
 3. Hanger Rods: Continuous-thread rod, nuts, and washer made of galvanized steel.

2.6 THERMAL-HANGER SHIELD INSERTS

- A. Basis-of-Design Product: Subject to compliance with requirements, provide product indicated on Drawings or comparable product by one of the following:
 - 1. Carpenter & Paterson, Inc.
 - 2. Clement Support Services.
 - 3. ERICO International Corporation.
 - 4. National Pipe Hanger Corporation.
 - 5. PHS Industries, Inc.
 - 6. Pipe Shields, Inc.; a subsidiary of Piping Technology & Products, Inc.
 - 7. Piping Technology & Products, Inc.
 - 8. Rilco Manufacturing Co., Inc.
 - 9. Value Engineered Products, Inc.
- B. Insulation-Insert Material for Cold Piping: ASTM C 552, Type II cellular glass with 100-psig minimum compressive strength and vapor barrier.
- C. Insulation-Insert Material for Hot Piping: ASTM C 552, Type II cellular glass with 100-psig minimum compressive strength.
- D. For Trapeze or Clamped Systems: Insert and shield shall cover entire circumference of pipe.
- E. For Clevis or Band Hangers: Insert and shield shall cover lower 180 degrees of pipe.
- F. Insert Length: Extend 2 inches beyond sheet metal shield for piping operating below ambient air temperature.

2.7 FASTENER SYSTEMS

- A. Powder-Actuated Fasteners: Threaded-steel stud, for use in hardened portland cement concrete with pull-out, tension, and shear capacities appropriate for supported loads and building materials where used.
- B. Mechanical-Expansion Anchors: Insert-wedge-type, zinc-coated steel anchors, for use in hardened portland cement concrete; with pull-out, tension, and shear capacities appropriate for supported loads and building materials where used.

2.8 PIPE STANDS

- A. General Requirements for Pipe Stands: Shop- or field-fabricated assemblies made of manufactured corrosion-resistant components to support roof-mounted piping.
- B. Compact Pipe Stand: One-piece plastic unit with integral-rod roller, pipe clamps, or V-shaped cradle to support pipe, for roof installation without membrane penetration.
- C. Low-Type, Single-Pipe Stand: One-piece plastic base unit with plastic roller, for roof installation without membrane penetration.
- D. High-Type, Single-Pipe Stand:
 - 1. Description: Assembly of base, vertical and horizontal members, and pipe support, for roof installation without membrane penetration.
 - 2. Base: Plastic.
 - 3. Vertical Members: Two or more cadmium-plated-steel or stainless-steel, continuous-thread rods.
 - 4. Horizontal Member: Cadmium-plated-steel or stainless-steel rod with plastic or stainless-steel, roller-type pipe support.
- E. High-Type, Multiple-Pipe Stand:
 - 1. Description: Assembly of bases, vertical and horizontal members, and pipe supports, for roof installation without membrane penetration.
 - 2. Bases: One or more; plastic.
 - 3. Vertical Members: Two or more protective-coated-steel channels.
 - 4. Horizontal Member: Protective-coated-steel channel.
 - 5. Pipe Supports: Galvanized-steel, clevis-type pipe hangers.
- F. Curb-Mounted-Type Pipe Stands: Shop- or field-fabricated pipe supports made from structural-steel shapes, continuous-thread rods, and rollers, for mounting on permanent stationary roof curb.

2.9 EQUIPMENT SUPPORTS

- A. Description: Welded, shop- or field-fabricated equipment support made from structural carbon-steel shapes.

2.10 MISCELLANEOUS MATERIALS

- A. Structural Steel: ASTM A 36/A 36M, carbon-steel plates, shapes, and bars; black and galvanized.
- B. Grout: ASTM C 1107, factory-mixed and -packaged, dry, hydraulic-cement, nonshrink and nonmetallic grout; suitable for interior and exterior applications.
 - 1. Properties: Nonstaining, noncorrosive, and nongaseous.
 - 2. Design Mix: 5000-psi, 28-day compressive strength.

PART 3 - EXECUTION

3.1 HANGER AND SUPPORT INSTALLATION

- A. Metal Pipe-Hanger Installation: Comply with MSS SP-69 and MSS SP-89. Install hangers, supports, clamps, and attachments as required to properly support piping from the building structure.
- B. Metal Trapeze Pipe-Hanger Installation: Comply with MSS SP-69 and MSS SP-89. Arrange for grouping of parallel runs of horizontal piping, and support together on field-fabricated trapeze pipe hangers.
 - 1. Pipes of Various Sizes: Support together and space trapezes for smallest pipe size or install intermediate supports for smaller diameter pipes as specified for individual pipe hangers.
 - 2. Field fabricate from ASTM A 36/A 36M, carbon-steel shapes selected for loads being supported. Weld steel according to AWS D1.1/D1.1M.
- C. Fiberglass Pipe-Hanger Installation: Comply with applicable portions of MSS SP-69 and MSS SP-89. Install hangers and attachments as required to properly support piping from building structure.
- D. Metal Framing System Installation: Arrange for grouping of parallel runs of piping, and support together on field-assembled metal framing systems.
- E. Fiberglass Strut System Installation: Arrange for grouping of parallel runs of piping, and support together on field-assembled fiberglass struts.
- F. Thermal-Hanger Shield Installation: Install in pipe hanger or shield for insulated piping.
- G. Fastener System Installation:
 - 1. Install powder-actuated fasteners for use in lightweight concrete or concrete slabs less than 4 inches thick in concrete after concrete is placed and completely cured. Use operators that are licensed by powder-actuated tool manufacturer. Install fasteners according to powder-actuated tool manufacturer's operating manual.

2. Install mechanical-expansion anchors in concrete after concrete is placed and completely cured. Install fasteners according to manufacturer's written instructions.
- H. Pipe Stand Installation:
1. Pipe Stand Types except Curb-Mounted Type: Assemble components and mount on smooth roof surface. Do not penetrate roof membrane.
 2. Curb-Mounted-Type Pipe Stands: Assemble components or fabricate pipe stand and mount on permanent, stationary roof curb. See Division 07 Section "Roof Accessories" for curbs.
- I. Install hangers and supports complete with necessary attachments, inserts, bolts, rods, nuts, washers, and other accessories.
- J. Equipment Support Installation: Fabricate from welded-structural-steel shapes.
- K. Install hangers and supports to allow controlled thermal and seismic movement of piping systems, to permit freedom of movement between pipe anchors, and to facilitate action of expansion joints, expansion loops, expansion bends, and similar units.
- L. Install lateral bracing with pipe hangers and supports to prevent swaying.
- M. Install building attachments within concrete slabs or attach to structural steel. Install additional attachments at concentrated loads, including valves, flanges, and strainers, NPS 2-1/2 and larger and at changes in direction of piping. Install concrete inserts before concrete is placed; fasten inserts to forms and install reinforcing bars through openings at top of inserts.
- N. Load Distribution: Install hangers and supports so that piping live and dead loads and stresses from movement will not be transmitted to connected equipment.
- O. Pipe Slopes: Install hangers and supports to provide indicated pipe slopes and to not exceed maximum pipe deflections allowed by ASME B31.9 for building services piping.
- P. Insulated Piping:
1. Attach clamps and spacers to piping.
 - a. Piping Operating above Ambient Air Temperature: Clamp may project through insulation.
 - b. Piping Operating below Ambient Air Temperature: Use thermal-hanger shield insert with clamp sized to match OD of insert.
 - c. Do not exceed pipe stress limits allowed by ASME B31.9 for building services piping.
 2. Install MSS SP-58, Type 39, protection saddles if insulation without vapor barrier is indicated. Fill interior voids with insulation that matches adjoining insulation.

- a. Option: Thermal-hanger shield inserts may be used. Include steel weight-distribution plate for pipe NPS 4 and larger if pipe is installed on rollers.
3. Install MSS SP-58, Type 40, protective shields on cold piping with vapor barrier. Shields shall span an arc of 180 degrees.
 - a. Option: Thermal-hanger shield inserts may be used. Include steel weight-distribution plate for pipe NPS 4 and larger if pipe is installed on rollers.
4. Shield Dimensions for Pipe: Not less than the following:
 - a. NPS 1/4 to NPS 3-1/2: 12 inches long and 0.048 inch thick.
 - b. NPS 4: 12 inches long and 0.06 inch thick.
 - c. NPS 5 and NPS 6: 18 inches long and 0.06 inch thick.
 - d. NPS 8 to NPS 14: 24 inches long and 0.075 inch thick.
 - e. NPS 16 to NPS 24: 24 inches long and 0.105 inch thick.
5. Pipes NPS 8 and Larger: Include wood or reinforced calcium-silicate-insulation inserts of length at least as long as protective shield.
6. Thermal-Hanger Shields: Install with insulation same thickness as piping insulation.

3.2 EQUIPMENT SUPPORTS

- A. Fabricate structural-steel stands to suspend equipment from structure overhead or to support equipment above floor.
- B. Grouting: Place grout under supports for equipment and make bearing surface smooth.
- C. Provide lateral bracing, to prevent swaying, for equipment supports.

3.3 METAL FABRICATIONS

- A. Cut, drill, and fit miscellaneous metal fabrications for trapeze pipe hangers and equipment supports.
- B. Fit exposed connections together to form hairline joints. Field weld connections that cannot be shop welded because of shipping size limitations.
- C. Field Welding: Comply with AWS D1.1/D1.1M procedures for shielded, metal arc welding; appearance and quality of welds; and methods used in correcting welding work; and with the following:

1. Use materials and methods that minimize distortion and develop strength and corrosion resistance of base metals.
2. Obtain fusion without undercut or overlap.
3. Remove welding flux immediately.
4. Finish welds at exposed connections so no roughness shows after finishing and so contours of welded surfaces match adjacent contours.

3.4 ADJUSTING

- A. Hanger Adjustments: Adjust hangers to distribute loads equally on attachments and to achieve indicated slope of pipe.
- B. Trim excess length of continuous-thread hanger and support rods to 1-1/2 inches.

3.5 PAINTING

- A. Touchup: Clean field welds and abraded areas of shop paint. Paint exposed areas immediately after erecting hangers and supports. Use same materials as used for shop painting. Comply with SSPC-PA 1 requirements for touching up field-painted surfaces.
 1. Apply paint by brush or spray to provide a minimum dry film thickness of 2.0 mils.
- B. Touchup: Cleaning and touchup painting of field welds, bolted connections, and abraded areas of shop paint on miscellaneous metal are specified in Division 09 painting Sections.
- C. Galvanized Surfaces: Clean welds, bolted connections, and abraded areas and apply galvanizing-repair paint to comply with ASTM A 780.

3.6 HANGER AND SUPPORT SCHEDULE

- A. Specific hanger and support requirements are in Sections specifying piping systems and equipment.
- B. Comply with MSS SP-69 for pipe-hanger selections and applications that are not specified in piping system Sections.
- C. Use hangers and supports with galvanized metallic coatings for piping and equipment that will not have field-applied finish.
- D. Use nonmetallic coatings on attachments for electrolytic protection where attachments are in direct contact with copper tubing.
- E. Use carbon-steel metal framing systems and attachments for general service applications.

- F. Use fiberglass pipe hangers and fiberglass strut systems and corrosion-resistant attachments for hostile environment applications.
- G. Use copper-plated pipe hangers and stainless-steel attachments for copper piping and tubing.
- H. Use padded hangers for piping that is subject to scratching.
- I. Use thermal-hanger shield inserts for insulated piping and tubing.
- J. Horizontal-Piping Hangers and Supports: Unless otherwise indicated and except as specified in piping system Sections, install the following types:
 - 1. Adjustable, Steel Clevis Hangers (MSS Type 1): For suspension of noninsulated or insulated, stationary pipes NPS 1/2 to NPS 30.
 - 2. Yoke-Type Pipe Clamps (MSS Type 2): For suspension of up to 1050 deg F, pipes NPS 4 to NPS 24, requiring up to 4 inches of insulation.
 - 3. Carbon- or Alloy-Steel, Double-Bolt Pipe Clamps (MSS Type 3): For suspension of pipes NPS 3/4 to NPS 36, requiring clamp flexibility and up to 4 inches of insulation.
 - 4. Steel Pipe Clamps (MSS Type 4): For suspension of cold and hot pipes NPS 1/2 to NPS 24 if little or no insulation is required.
 - 5. Pipe Hangers (MSS Type 5): For suspension of pipes NPS 1/2 to NPS 4, to allow off-center closure for hanger installation before pipe erection.
 - 6. Adjustable, Swivel Split- or Solid-Ring Hangers (MSS Type 6): For suspension of noninsulated, stationary pipes NPS 3/4 to NPS 8.
 - 7. Adjustable, Steel Band Hangers (MSS Type 7): For suspension of noninsulated, stationary pipes NPS 1/2 to NPS 8.
 - 8. Adjustable Band Hangers (MSS Type 9): For suspension of noninsulated, stationary pipes NPS 1/2 to NPS 8.
 - 9. Adjustable, Swivel-Ring Band Hangers (MSS Type 10): For suspension of noninsulated, stationary pipes NPS 1/2 to NPS 8.
 - 10. Split Pipe Ring with or without Turnbuckle Hangers (MSS Type 11): For suspension of noninsulated, stationary pipes NPS 3/8 to NPS 8.
 - 11. Extension Hinged or Two-Bolt Split Pipe Clamps (MSS Type 12): For suspension of noninsulated, stationary pipes NPS 3/8 to NPS 3.
 - 12. U-Bolts (MSS Type 24): For support of heavy pipes NPS 1/2 to NPS 30.
 - 13. Clips (MSS Type 26): For support of insulated pipes not subject to expansion or contraction.

14. Pipe Saddle Supports (MSS Type 36): For support of pipes NPS 4 to NPS 36, with steel-pipe base stanchion support and cast-iron floor flange or carbon-steel plate.
 15. Pipe Stanchion Saddles (MSS Type 37): For support of pipes NPS 4 to NPS 36, with steel-pipe base stanchion support and cast-iron floor flange or carbon-steel plate, and with U-bolt to retain pipe.
 16. Adjustable Pipe Saddle Supports (MSS Type 38): For stanchion-type support for pipes NPS 2-1/2 to NPS 36 if vertical adjustment is required, with steel-pipe base stanchion support and cast-iron floor flange.
 17. Single-Pipe Rolls (MSS Type 41): For suspension of pipes NPS 1 to NPS 30, from two rods if longitudinal movement caused by expansion and contraction might occur.
 18. Adjustable Roller Hangers (MSS Type 43): For suspension of pipes NPS 2-1/2 to NPS 24, from single rod if horizontal movement caused by expansion and contraction might occur.
 19. Complete Pipe Rolls (MSS Type 44): For support of pipes NPS 2 to NPS 42 if longitudinal movement caused by expansion and contraction might occur but vertical adjustment is not necessary.
 20. Pipe Roll and Plate Units (MSS Type 45): For support of pipes NPS 2 to NPS 24 if small horizontal movement caused by expansion and contraction might occur and vertical adjustment is not necessary.
 21. Adjustable Pipe Roll and Base Units (MSS Type 46): For support of pipes NPS 2 to NPS 30 if vertical and lateral adjustment during installation might be required in addition to expansion and contraction.
- K. Vertical-Piping Clamps: Unless otherwise indicated and except as specified in piping system Sections, install the following types:
1. Extension Pipe or Riser Clamps (MSS Type 8): For support of pipe risers NPS 3/4 to NPS 24.
 2. Carbon- or Alloy-Steel Riser Clamps (MSS Type 42): For support of pipe risers NPS 3/4 to NPS 24 if longer ends are required for riser clamps.
- L. Hanger-Rod Attachments: Unless otherwise indicated and except as specified in piping system Sections, install the following types:
1. Steel Turnbuckles (MSS Type 13): For adjustment up to 6 inches for heavy loads.
 2. Steel Clevises (MSS Type 14): For 120 to 450 deg F piping installations.
 3. Swivel Turnbuckles (MSS Type 15): For use with MSS Type 11, split pipe rings.
 4. Malleable-Iron Sockets (MSS Type 16): For attaching hanger rods to various types of building attachments.

5. Steel Weldless Eye Nuts (MSS Type 17): For 120 to 450 deg F piping installations.
- M. Building Attachments: Unless otherwise indicated and except as specified in piping system Sections, install the following types:
1. Steel or Malleable Concrete Inserts (MSS Type 18): For upper attachment to suspend pipe hangers from concrete ceiling.
 2. Top-Beam C-Clamps (MSS Type 19): For use under roof installations with bar-joist construction, to attach to top flange of structural shape.
 3. Side-Beam or Channel Clamps (MSS Type 20): For attaching to bottom flange of beams, channels, or angles.
 4. Center-Beam Clamps (MSS Type 21): For attaching to center of bottom flange of beams.
 5. Welded Beam Attachments (MSS Type 22): For attaching to bottom of beams if loads are considerable and rod sizes are large.
 6. C-Clamps (MSS Type 23): For structural shapes.
 7. Top-Beam Clamps (MSS Type 25): For top of beams if hanger rod is required tangent to flange edge.
 8. Side-Beam Clamps (MSS Type 27): For bottom of steel I-beams.
 9. Steel-Beam Clamps with Eye Nuts (MSS Type 28): For attaching to bottom of steel I-beams for heavy loads.
 10. Linked-Steel Clamps with Eye Nuts (MSS Type 29): For attaching to bottom of steel I-beams for heavy loads, with link extensions.
 11. Malleable-Beam Clamps with Extension Pieces (MSS Type 30): For attaching to structural steel.
 12. Welded-Steel Brackets: For support of pipes from below or for suspending from above by using clip and rod. Use one of the following for indicated loads:
 - a. Light (MSS Type 31): 750 lb.
 - b. Medium (MSS Type 32): 1500 lb.
 - c. Heavy (MSS Type 33): 3000 lb.
 13. Side-Beam Brackets (MSS Type 34): For sides of steel or wooden beams.
 14. Plate Lugs (MSS Type 57): For attaching to steel beams if flexibility at beam is required.
 15. Horizontal Travelers (MSS Type 58): For supporting piping systems subject to linear horizontal movement where headroom is limited.

- N. Saddles and Shields: Unless otherwise indicated and except as specified in piping system Sections, install the following types:
1. Steel-Pipe-Covering Protection Saddles (MSS Type 39): To fill interior voids with insulation that matches adjoining insulation.
 2. Protection Shields (MSS Type 40): Of length recommended in writing by manufacturer to prevent crushing insulation.
 3. Thermal-Hanger Shield Inserts: For supporting insulated pipe.
- O. Spring Hangers and Supports: Unless otherwise indicated and except as specified in piping system Sections, install the following types:
1. Restraint-Control Devices (MSS Type 47): Where indicated to control piping movement.
 2. Spring Cushions (MSS Type 48): For light loads if vertical movement does not exceed 1-1/4 inches.
 3. Spring-Cushion Roll Hangers (MSS Type 49): For equipping Type 41, roll hanger with springs.
 4. Spring Sway Braces (MSS Type 50): To retard sway, shock, vibration, or thermal expansion in piping systems.
 5. Variable-Spring Hangers (MSS Type 51): Preset to indicated load and limit variability factor to 25 percent to allow expansion and contraction of piping system from hanger.
 6. Variable-Spring Base Supports (MSS Type 52): Preset to indicated load and limit variability factor to 25 percent to allow expansion and contraction of piping system from base support.
 7. Variable-Spring Trapeze Hangers (MSS Type 53): Preset to indicated load and limit variability factor to 25 percent to allow expansion and contraction of piping system from trapeze support.
 8. Constant Supports: For critical piping stress and if necessary to avoid transfer of stress from one support to another support, critical terminal, or connected equipment. Include auxiliary stops for erection, hydrostatic test, and load-adjustment capability. These supports include the following types:
 - a. Horizontal (MSS Type 54): Mounted horizontally.
 - b. Vertical (MSS Type 55): Mounted vertically.
 - c. Trapeze (MSS Type 56): Two vertical-type supports and one trapeze member.
- P. Comply with MSS SP-69 for trapeze pipe-hanger selections and applications that are not specified in piping system Sections.

- Q. Comply with MFMA-103 for metal framing system selections and applications that are not specified in piping system Sections.
- R. Use mechanical-expansion anchors instead of building attachments where required in concrete construction.

END OF SECTION 230529

SECTION 230533 - HEAT TRACING FOR HVAC PIPING

PART 1 - GENERAL

1.1 RELATED DOCUMENTS

- A. Drawings and general provisions of the Contract, including General and Supplementary Conditions and Division 01 Specification Sections, apply to this Section.

1.2 SUMMARY

- A. Section includes heat tracing for HVAC piping with the following electric heating cables:
 - 1. Plastic insulated, series resistance.
 - 2. Self-regulating, parallel resistance.

1.3 ACTION SUBMITTALS

- A. Product Data: For each type of product.
 - 1. Include rated capacities, operating characteristics, and furnished specialties and accessories.
 - 2. Schedule heating capacity, length of cable, spacing, and electrical power requirement for each electric heating cable required.
- B. Shop Drawings: For electric heating cable.
 - 1. Include plans, elevations, sections, and attachment details.
 - 2. Include diagrams for power, signal, and control wiring.

1.4 INFORMATIONAL SUBMITTALS

- A. Field quality-control reports.
- B. Sample Warranty: For special warranty.

1.5 CLOSEOUT SUBMITTALS

- A. Operation and Maintenance Data: For electric heating cables to include in operation and maintenance manuals.

1.6 WARRANTY

- A. Special Warranty: Manufacturer agrees to repair or replace electric heating cable that fails in materials or workmanship within specified warranty period.
 - 1. Warranty Period: **Three** years from date of Substantial Completion.

PART 2 - PRODUCTS

2.1 PLASTIC-INSULATED, SERIES-RESISTANCE HEATING CABLES

- A. Manufacturers:
 - 1. RayChem
 - 2. Thermon
 - 3. BriskHeat
 - 4. Chromalox
- B. Comply with IEEE 515.1.
- C. Heating Element: Single- or dual-stranded resistor wire. Terminate with waterproof, factory-assembled, nonheating leads with connectors at both ends.
- D. Electrical Insulating Jacket: Minimum 4.0-mil Kapton with silicone, Tefzel, or polyolefin.
- E. Cable Cover: Aluminum braid and silicone or Hylar outer jacket.
- F. Maximum Operating Temperature (Power On): 150 deg .
- G. Maximum Exposure Temperature (Power Off): 185 deg F.
- H. Electrical Components, Devices, and Accessories: Listed and labeled as defined in NFPA 70, by a qualified testing agency, and marked for intended location and application.
- I. Capacities and Characteristics:
 - 1. Maximum Heat Output: 6 W/ft. maximum.
 - 2. Piping Diameter: As indicated on drawings.
 - 3. Number of Parallel Cables: Sized by manufacture to meet heat output.
 - 4. Spiral Wrap Pitch: Selected by manufacture to meet heat output.

5. Electrical Characteristics for Single-Circuit Connection: (Refer to Electrical drawings for circuit designation).

2.2 SELF-REGULATING, PARALLEL-RESISTANCE HEATING CABLES

- A. Manufacturers:
 1. RayChem
 2. Thermon
 3. BriskHeat
 4. Chromalox
- B. Comply with IEEE 515.1.
- C. Heating Element: Pair of parallel No. 16 AWG, nickel-coated, stranded copper bus wires embedded in crosslinked conductive polymer core, which varies heat output in response to temperature along its length. Terminate with waterproof, factory-assembled, nonheating leads with connectors at one end, and seal the opposite end watertight. Cable shall be capable of crossing over itself once without overheating.
- D. Electrical Insulating Jacket: Flame-retardant polyolefin.
- E. Cable Cover: Stainless-steel braid and polyolefin outer jacket with ultraviolet inhibitor.
- F. Maximum Operating Temperature (Power On): 150 deg F
- G. Maximum Exposure Temperature (Power Off): 185 deg F.
- H. Electrical Components, Devices, and Accessories: Listed and labeled as defined in NFPA 70, by a qualified testing agency, and marked for intended location and application.
- I. Capacities and Characteristics:
 1. Maximum Heat Output: 5 W/ft..
 2. Piping Diameter: As indicated on drawings.
 3. Number of Parallel Cables: Sized by manufacture to meet heat output.
 4. Spiral Wrap Pitch: Selected by manufacture to meet heat output
 5. Electrical Characteristics for Single-Circuit Connection (Refer to Electrical drawings for circuit designation).

2.3 CONTROLS

- A. Remote bulb unit with adjustable temperature range from 30 to 50 deg F.
- B. Snap action; open-on-rise, single-pole switch with minimum current rating adequate for connected cable.
- C. Remote bulb on capillary, resistance temperature device, or thermistor for directly sensing pipe-wall temperature.
- D. Corrosion-resistant, waterproof control enclosure.

2.4 ACCESSORIES

- A. Cable Installation Accessories: Fiberglass tape, heat-conductive putty, cable ties, silicone end seals and splice kits, and installation clips all furnished by manufacturer, or as recommended in writing by manufacturer.
- B. Warning Labels: Refer to Section 230553 "Identification for HVAC Piping and Equipment."
- C. Warning Tape: Continuously printed "Electrical Tracing"; vinyl, at least 3 mils thick, and with pressure-sensitive, permanent, waterproof, self-adhesive back.
 - 1. Width for Markers on Pipes with OD, Including Insulation, Less Than 6 Inches: 3/4 inch minimum.
 - 2. Width for Markers on Pipes with OD, Including Insulation, 6 Inches or Larger: 1-1/2 inches minimum.

PART 3 - EXECUTION

3.1 EXAMINATION

- A. Examine surfaces and substrates to receive electric heating cables for compliance with requirements for installation tolerances and other conditions affecting performance.
 - 1. Ensure surfaces and pipes in contact with electric heating cables are free of burrs and sharp protrusions.
- B. Proceed with installation only after unsatisfactory conditions have been corrected.

3.2 INSTALLATION

- A. Install electric heating cable across expansion joints according to manufacturer's written instructions; use slack cable to allow movement without damage to cable.

- B. Install electric heating cables after piping has been tested and before insulation is installed.
- C. Install electric heating cables according to IEEE 515.1.
- D. Install insulation over piping with electric cables according to Section 230719 "HVAC Piping Insulation."
- E. Install warning tape on piping insulation where piping is equipped with electric heating cables.
- F. Set field-adjustable switches and circuit-breaker trip ranges.

3.3 CONNECTIONS

- A. Ground equipment according to Section 260526 "Grounding and Bonding for Electrical Systems."
- B. Connect wiring according to Section 260519 "Low-Voltage Electrical Power Conductors and Cables."

3.4 FIELD QUALITY CONTROL

- A. Testing Agency: Engage a qualified testing agency to perform tests and inspections.
- B. Manufacturer's Field Service: Engage a factory-authorized service representative to test and inspect components, assemblies, and equipment installations, including connections.
- C. Perform the following tests and inspections with the assistance of a factory-authorized service representative:
 - 1. Perform tests after cable installation but before application of coverings such as insulation, wall or ceiling construction, or concrete.
 - 2. Test cables for electrical continuity and insulation integrity before energizing.
 - 3. Test cables to verify rating and power input. Energize and measure voltage and current simultaneously.
- D. Repeat tests for continuity, insulation resistance, and input power after applying thermal insulation on pipe-mounted cables.
- E. Cables will be considered defective if they do not pass tests and inspections.
- F. Prepare test and inspection reports.

3.5 PROTECTION

- A. Protect installed heating cables, including nonheating leads, from damage during construction.

- B. Remove and replace damaged heat-tracing cables.

END OF SECTION 230533

SECTION 230548 - VIBRATION AND SEISMIC CONTROLS FOR HVAC

PART 1 - GENERAL

1.1 RELATED DOCUMENTS

- A. Drawings and general provisions of the Contract, including General and Supplementary Conditions and Division 01 Specification Sections, apply to this Section.

1.2 SUMMARY

- A. Section Includes:

1. Elastomeric isolation pads.
2. Elastomeric isolation mounts.
3. Restrained elastomeric isolation mounts.
4. Open-spring isolators.
5. Housed-spring isolators.
6. Restrained-spring isolators.
7. Housed-restrained-spring isolators.
8. Pipe-riser resilient supports.
9. Resilient pipe guides.
10. Air-spring isolators.
11. Restrained-air-spring isolators.
12. Elastomeric hangers.
13. Spring hangers.
14. Snubbers.
15. Restraint channel bracings.
16. Restraint cables.
17. Seismic-restraint accessories.
18. Mechanical anchor bolts.
19. Adhesive anchor bolts.
20. Vibration isolation equipment bases.
21. Restrained isolation roof-curb rails.

1.3 DEFINITIONS

- A. IBC: International Building Code.
- B. ICC-ES: ICC-Evaluation Service.
- C. OSHPD: Office of Statewide Health Planning & Development.

1.4 ACTION SUBMITTALS

A. Product Data: For each type of product.

1. Include rated load, rated deflection, and overload capacity for each vibration isolation device.
2. Illustrate and indicate style, material, strength, fastening provision, and finish for each type and size of vibration isolation device and seismic-restraint component required.
 - a. Tabulate types and sizes of seismic restraints, complete with report numbers and rated strength in tension and shear as evaluated by an evaluation service member of ICC-ES.
 - b. Annotate to indicate application of each product submitted and compliance with requirements.
3. Interlocking Snubbers: Include ratings for horizontal, vertical, and combined loads.

B. Shop Drawings:

1. Detail fabrication and assembly of equipment bases. Detail fabrication including anchorages and attachments to structure and to supported equipment. Include adjustable motor bases, rails, and frames for equipment mounting.
2. Vibration Isolation Base Details: Detail fabrication including anchorages and attachments to structure and to supported equipment. Include adjustable motor bases, rails, and frames for equipment mounting.

C. Delegated-Design Submittal: For each vibration isolation and seismic-restraint device.

1. Include design calculations and details for selecting vibration isolators, seismic restraints, and vibration isolation bases complying with performance requirements, design criteria, and analysis data signed and sealed by the qualified professional engineer responsible for their preparation.
2. Design Calculations: Calculate static and dynamic loading due to equipment weight, operation, and seismic and wind forces required to select vibration isolators and seismic and wind restraints and for designing vibration isolation bases.
 - a. Coordinate design calculations with wind load calculations required for equipment mounted outdoors. Comply with requirements in other Sections for equipment mounted outdoors.
3. Riser Supports: Include riser diagrams and calculations showing anticipated expansion and contraction at each support point, initial and final loads on building structure, spring deflection changes, and seismic loads. Include certification that riser system was examined for excessive stress and that none exists.
4. Seismic and Wind Restraint Details:
 - a. Design Analysis: To support selection and arrangement of seismic and wind restraints. Include calculations of combined tensile and shear loads.
 - b. Details: Indicate fabrication and arrangement. Detail attachments of restraints to the restrained items and to the structure. Show attachment locations, methods, and

spacings. Identify components, list their strengths, and indicate directions and values of forces transmitted to the structure during seismic events. Indicate association with vibration isolation devices.

- c. Coordinate seismic-restraint and vibration isolation details with wind-restraint details required for equipment mounted outdoors. Comply with requirements in other Sections for equipment mounted outdoors.
- d. Preapproval and Evaluation Documentation: By an evaluation service member of ICC-ES, showing maximum ratings of restraint items and the basis for approval (tests or calculations).

1.5 INFORMATIONAL SUBMITTALS

- A. Coordination Drawings: Show coordination of vibration isolation device installation and seismic bracing for HVAC piping and equipment with other systems and equipment in the vicinity, including other supports and restraints, if any.
- B. Qualification Data: For professional engineer and testing agency.
- C. Welding certificates.
- D. Air-Mounting System Performance Certification: Include natural frequency, load, and damping test data.
- E. Field quality-control reports.

1.6 CLOSEOUT SUBMITTALS

- A. Operation and Maintenance Data: For air-spring mounts and restrained-air-spring mounts as applicable to include in operation and maintenance manuals.

1.7 QUALITY ASSURANCE

- A. Testing Agency Qualifications: An independent agency, with the experience and capability to conduct the testing indicated, that is an NRTL as defined by OSHA in 29 CFR 1910.7 and that is acceptable to authorities having jurisdiction.
- B. Comply with seismic-restraint requirements in the IBC unless requirements in this Section are more stringent.
- C. Welding Qualifications: Qualify procedures and personnel according to AWS D1.1/D1.1M, "Structural Welding Code - Steel."
- D. Seismic-restraint devices shall have horizontal and vertical load testing and analysis and shall bear anchorage preapproval OPA number from OSHPD, preapproval by ICC-ES, or preapproval by another agency acceptable to authorities having jurisdiction, showing maximum seismic-restraint ratings. Ratings based on independent testing are preferred to ratings based on calculations. If preapproved ratings are unavailable, submittals based on independent testing are

preferred. Calculations (including combining shear and tensile loads) to support seismic-restraint designs must be signed and sealed by a qualified professional engineer.

PART 2 - PRODUCTS

2.1 PERFORMANCE REQUIREMENTS

A. Wind-Restraint Loading:

1. Basic Wind Speed: 93 MPH.
2. Building Classification Category: II.
3. Minimum 16.1 lb/sq. ft. multiplied by maximum area of HVAC component projected on vertical plane normal to wind direction, and 45 degrees either side of normal.

B. Seismic-Restraint Loading:

1. Site Class as Defined in the IBC: D.
2. Assigned Seismic Use Group or Building Category as Defined in the IBC: II.
 - a. Component Importance Factor: 1.0.
 - b. Component Response Modification Factor: 3.5.
 - c. Component Amplification Factor: 2.5.
3. Design Spectral Response Acceleration at Short Periods: (0.2 Second)
4. Design Spectral Response Acceleration at 1.0-Second Period: (0.072)
5. Rated strengths, features, and applications shall be as defined in reports by an evaluation service member of ICC-ES.
 - a. Structural Safety Factor: Allowable strength in tension, shear, and pullout force of components shall be at least four times the maximum seismic forces to which they are subjected.

2.2 ELASTOMERIC ISOLATION PADS

A. Elastomeric Isolation Pads:

1. Fabrication: Single or multiple layers of sufficient durometer stiffness for uniform loading over pad area.
2. Size: Factory or field cut to match requirements of supported equipment.
3. Pad Material: Oil and water resistant with elastomeric properties.
4. Surface Pattern: Ribbed pattern.
5. Infused nonwoven cotton or synthetic fibers.
6. Load-bearing metal plates adhered to pads.
7. Sandwich-Core Material: elastomeric.
 - a. Surface Pattern: Ribbed pattern.
 - b. Infused nonwoven cotton or synthetic fibers.

2.3 ELASTOMERIC ISOLATION MOUNTS

- A. Double-Deflection, Elastomeric Isolation Mounts:
- B. Manufactures:
 - 1. Kinetics Noise Control, Inc.
 - 2. Korfund
 - 3. Mason Industries, Inc.
 - 4. Vibration Eliminator Company
 - 5. Vibration Isolation
 - 6. Vibration Mountings & control
 - 7. Novia; A division of C&P
- C. Mounting Plates:
 - a. Top Plate: Encapsulated steel load transfer top plates, factory drilled and threaded with threaded studs or bolts.
 - b. Baseplate: Encapsulated steel bottom plates with holes provided for anchoring to support structure.
- D. Elastomeric Material: Molded, oil-resistant rubber, neoprene, or other elastomeric material.

2.4 RESTRAINED ELASTOMERIC ISOLATION MOUNTS

- A. Restrained Elastomeric Isolation Mounts:
- B. Manufactures:
 - 1. Kinetics Noise Control, Inc.
 - 2. Korfund
 - 3. Mason Industries, Inc.
 - 4. Vibration Eliminator Company
 - 5. Vibration Isolation
 - 6. Vibration Mountings & control
 - 7. Novia; A division of C&P
- 1. Description: All-directional isolator with seismic restraints containing two separate and opposing elastomeric elements that prevent central threaded element and attachment hardware from contacting the housing during normal operation.
 - a. Housing: Cast-ductile iron or welded steel.
 - b. Elastomeric Material: Molded, oil-resistant rubber, neoprene, or other elastomeric material.

2.5 OPEN-SPRING ISOLATORS

- A. Freestanding, Laterally Stable, Open-Spring Isolators:
- B. Manufactures:
 - 1. Kinetics Noise Control, Inc.

2. Korfund
 3. Mason Industries, Inc.
 4. Vibration Eliminator Company
 5. Vibration Isolation
 6. Vibration Mountings & control
 7. Novia; A division of C&P
- C. Outside Spring Diameter: Not less than 80 percent of the compressed height of the spring at rated load.
- D. Minimum Additional Travel: 50 percent of the required deflection at rated load.
- E. Lateral Stiffness: More than 80 percent of rated vertical stiffness.
- F. Overload Capacity: Support 200 percent of rated load, fully compressed, without deformation or failure.
- G. Baseplates: Factory-drilled steel plate for bolting to structure with an elastomeric isolator pad attached to the underside. Baseplates shall limit floor load to 500 psig.
- H. Top Plate and Adjustment Bolt: Threaded top plate with adjustment bolt and cap screw to fasten and level equipment.

2.6 HOUSED-SPRING ISOLATORS

- A. Freestanding, Laterally Stable, Open-Spring Isolators in Two-Part Telescoping Housing:
- B. Manufactures:
1. Kinetics Noise Control, Inc.
 2. Korfund
 3. Mason Industries, Inc.
 4. Vibration Eliminator Company
 5. Vibration Isolation
 6. Vibration Mountings & control
 7. Novia; A division of C&P
- C. Outside Spring Diameter: Not less than 80 percent of the compressed height of the spring at rated load.
- D. Minimum Additional Travel: 50 percent of the required deflection at rated load.
- E. Lateral Stiffness: More than 80 percent of rated vertical stiffness.
- F. Overload Capacity: Support 200 percent of rated load, fully compressed, without deformation or failure.
- G. Two-Part Telescoping Housing: A steel top and bottom frame separated by an elastomeric material and enclosing the spring isolators.

1. Drilled base housing for bolting to structure with an elastomeric isolator pad attached to the underside. Bases shall limit floor load to 500 psig.
2. Top housing with elastomeric pad.

2.7 RESTRAINED-SPRING ISOLATORS

- A. Freestanding, Laterally Stable, Open-Spring Isolators with Vertical-Limit Stop Restraint:
- B. Manufactures:
 1. Kinetics Noise Control, Inc.
 2. Korfund
 3. Mason Industries, Inc.
 4. Vibration Eliminator Company
 5. Vibration Isolation
 6. Vibration Mountings & control
 7. Novia; A division of C&P
- C. Housing: Steel housing with vertical-limit stops to prevent spring extension due to weight being removed.
 1. Base with holes for bolting to structure with an elastomeric isolator pad attached to the underside. Bases shall limit floor load to 500 psig.
 2. Top plate with elastomeric pad.
 3. Internal leveling bolt that acts as blocking during installation.
- D. Restraint: Limit stop as required for equipment and authorities having jurisdiction.
- E. Outside Spring Diameter: Not less than 80 percent of the compressed height of the spring at rated load.
- F. Minimum Additional Travel: 50 percent of the required deflection at rated load.
- G. Lateral Stiffness: More than 80 percent of rated vertical stiffness.
- H. Overload Capacity: Support 200 percent of rated load, fully compressed, without deformation or failure.

2.8 HOUSED-RESTRAINED-SPRING ISOLATORS

- A. Freestanding, Steel, Open-Spring Isolators with Vertical-Limit Stop Restraint in Two-Part Telescoping Housing:
- B. Manufactures:
 1. Kinetics Noise Control, Inc.
 2. Korfund
 3. Mason Industries, Inc.
 4. Vibration Eliminator Company
 5. Vibration Isolation
 6. Vibration Mountings & control

7. Novia; A division of C&P

- C. Two-Part Telescoping Housing: A steel top and bottom frame separated by an elastomeric material and enclosing the spring isolators. Housings are equipped with adjustable snubbers to limit vertical movement.
 - 1. Drilled base housing for bolting to structure with an elastomeric isolator pad attached to the underside. Bases shall limit floor load to 500 psig.
 - 2. Threaded top housing with adjustment bolt and cap screw to fasten and level equipment.
- D. Outside Spring Diameter: Not less than 80 percent of the compressed height of the spring at rated load.
- E. Minimum Additional Travel: 50 percent of the required deflection at rated load.
- F. Lateral Stiffness: More than 80 percent of rated vertical stiffness.
- G. Overload Capacity: Support 200 percent of rated load, fully compressed, without deformation or failure.

2.9 PIPE-RISER RESILIENT SUPPORT

- A. Description: All-directional, acoustical pipe anchor consisting of two steel tubes separated by a minimum 1/2-inch thick neoprene.
- B. Manufactures:
 - 1. Kinetics Noise Control, Inc.
 - 2. Korfund
 - 3. Mason Industries, Inc.
 - 4. Vibration Eliminator Company
 - 5. Vibration Isolation
 - 6. Vibration Mountings & control
 - 7. Novia; A division of C&P
- C. Vertical-Limit Stops: Steel and neoprene vertical-limit stops arranged to prevent vertical travel in both directions.
- D. Maximum Load Per Support: 500 psig on isolation material providing equal isolation in all directions.

2.10 RESILIENT PIPE GUIDES

- A. Description: Telescopic arrangement of two steel tubes or post and sleeve arrangement separated by a minimum 1/2-inch thick neoprene.
 - 1. Factory-Set Height Guide with Shear Pin: Shear pin shall be removable and reinsertable to allow for selection of pipe movement. Guides shall be capable of motion to meet location requirements.

2.11 AIR-SPRING ISOLATORS

- A. Freestanding, Single or Multiple, Compressed-Air Bellows:
- B. Manufactures:
 - 1. Kinetics Noise Control, Inc.
 - 2. Korfund
 - 3. Mason Industries, Inc.
 - 4. Vibration Eliminator Company
 - 5. Vibration Isolation
 - 6. Vibration Mountings & control
 - 7. Novia; A division of C&P
 - a. Bellows Assembly: Upper and lower powder-coated steel sections connected by a replaceable, flexible, nylon-reinforced neoprene bellows or similar elastomeric material.
 - b. Maximum Natural Frequency: 3 Hz.
 - c. Operating Pressure Range: 25 to 100 psig.
 - d. Burst Pressure: At least three times manufacturer's published maximum operating pressure.
 - e. Tank valves.

2.12 RESTRAINED-AIR-SPRING ISOLATORS

- A. Freestanding, Single or Multiple, Compressed-Air Bellows with Vertical-Limit Stop Restraint:
- B. Manufactures:
 - 1. Kinetics Noise Control, Inc.
 - 2. Korfund
 - 3. Mason Industries, Inc.
 - 4. Vibration Eliminator Company
 - 5. Vibration Isolation
 - 6. Vibration Mountings & control
 - 7. Novia; A division of C&P
- C. Housing: Steel housing with vertical-limit stops to prevent spring extension due to weight being removed.
- D. Base with holes for bolting to structure with an elastomeric isolator pad attached to the underside. Bases shall limit floor load to 500 psig.
- E. Top plate with elastomeric pad.
- F. Internal leveling bolt that acts as blocking during installation.
- G. Restraint: Limit stop as required for equipment and authorities having jurisdiction.
- H. Outside Spring Diameter: Not less than 80 percent of the compressed height of the spring at rated load.

- I. Minimum Additional Travel: 50 percent of the required deflection at rated load.
- J. Lateral Stiffness: More than 80 percent of rated vertical stiffness.
- K. Overload Capacity: Support 200 percent of rated load, fully compressed, without deformation or failure.
- L. Bellows Assembly: Upper and lower powder-coated steel sections connected by a replaceable, flexible, nylon-reinforced neoprene bellows or similar elastomeric material.
- M. Maximum Natural Frequency: 3 Hz.
- N. Operating Pressure Range: 25 to 100 psig.
- O. Burst Pressure: At least three times manufacturer's published maximum operating pressure.
- P. Tank valves.

2.13 ELASTOMERIC HANGERS

- A. Elastomeric Mount in a Steel Frame with Upper and Lower Steel Hanger Rods:
- B. Manufactures:
 - 1. Kinetics Noise Control, Inc.
 - 2. Korfund
 - 3. Mason Industries, Inc.
 - 4. Vibration Eliminator Company
 - 5. Vibration Isolation
 - 6. Vibration Mountings & control
 - 7. Novia; A division of C&P
- C. Frame: Steel, fabricated with a connection for an upper threaded hanger rod and an opening on the underside to allow for a maximum of 30 degrees of angular lower hanger-rod misalignment without binding or reducing isolation efficiency.
- D. Dampening Element: Molded, oil-resistant rubber, neoprene, or other elastomeric material with a projecting bushing for the underside opening preventing steel to steel contact.

2.14 SPRING HANGERS

- A. Combination Coil-Spring and Elastomeric-Insert Hanger with Spring and Insert in Compression:
- B. Manufactures:
 - 1. Kinetics Noise Control, Inc.
 - 2. Korfund
 - 3. Mason Industries, Inc.
 - 4. Vibration Eliminator Company

5. Vibration Isolation
 6. Vibration Mountings & control
 7. Novia; A division of C&P
- C. Frame: Steel, fabricated for connection to threaded hanger rods and to allow for a maximum of 30 degrees of angular hanger-rod misalignment without binding or reducing isolation efficiency.
 - D. Outside Spring Diameter: Not less than 80 percent of the compressed height of the spring at rated load.
 - E. Minimum Additional Travel: 50 percent of the required deflection at rated load.
 - F. Lateral Stiffness: More than 80 percent of rated vertical stiffness.
 - G. Overload Capacity: Support 200 percent of rated load, fully compressed, without deformation or failure.
 - H. Elastomeric Element: Molded, oil-resistant rubber or neoprene. Steel-washer-reinforced cup to support spring and bushing projecting through bottom of frame.
 - I. Adjustable Vertical Stop: Steel washer with neoprene washer "up-stop" on lower threaded rod.
 - J. Self-centering hanger-rod cap to ensure concentricity between hanger rod and support spring coil.

2.15 SNUBBERS

- A. Manufactures:
 1. Kinetics Noise Control, Inc.
 2. Korfund
 3. Mason Industries, Inc.
 4. Vibration Eliminator Company
 5. Vibration Isolation
 6. Vibration Mountings & control
 7. Novia; A division of C&P
- B. Description: Factory fabricated using welded structural-steel shapes and plates, anchor bolts, and replaceable resilient isolation washers and bushings.
 1. Anchor bolts for attaching to concrete shall be seismic-rated, drill-in, and stud-wedge or female-wedge type.
 2. Resilient Isolation Washers and Bushings: Oil- and water-resistant neoprene.
 3. Maximum 1/4-inch air gap, and minimum 1/4-inch thick resilient cushion.

2.16 RESTRAINT CHANNEL BRACINGS

- A. Manufactures:
 1. Kinetics Noise Control, Inc.

2. Korfund
3. Mason Industries, Inc.
4. Vibration Eliminator Company
5. Vibration Isolation
6. Vibration Mountings & control
7. Novia; A division of C&P

- B. Description: MFMA-4, shop- or field-fabricated bracing assembly made of slotted steel channels with accessories for attachment to braced component at one end and to building structure at the other end and other matching components and with corrosion-resistant coating; rated in tension, compression, and torsion forces.

2.17 RESTRAINT CABLES

A. Manufactures:

1. Kinetics Noise Control, Inc.
2. Korfund
3. Mason Industries, Inc.
4. Vibration Eliminator Company
5. Vibration Isolation
6. Vibration Mountings & control
7. Novia; A division of C&P

- B. Restraint Cables: ASTM A603 galvanized steel cables. End connections made of steel assemblies with thimbles, brackets, swivel, and bolts designed for restraining cable service; with a minimum of two clamping bolts for cable engagement.

2.18 SEISMIC-RESTRAINT ACCESSORIES

A. Manufactures:

1. Kinetics Noise Control, Inc.
2. Korfund
3. Mason Industries, Inc.
4. Vibration Eliminator Company
5. Vibration Isolation
6. Vibration Mountings & control
7. Novia; A division of C&P

- B. Hanger-Rod Stiffener: Steel tube or steel slotted-support-system sleeve with internally bolted connections to hanger rod.

- C. Hinged and Swivel Brace Attachments: Multifunctional steel connectors for attaching hangers to rigid channel bracings and restraint cables.

- D. Bushings for Floor-Mounted Equipment Anchor Bolts: Neoprene bushings designed for rigid equipment mountings, and matched to type and size of anchor bolts and studs.

- E. Bushing Assemblies for Wall-Mounted Equipment Anchorage: Assemblies of neoprene elements and steel sleeves designed for rigid equipment mountings, and matched to type and size of attachment devices used.
- F. Resilient Isolation Washers and Bushings: One-piece, molded, oil- and water-resistant neoprene, with a flat washer face.

2.19 MECHANICAL ANCHOR BOLTS

- A. Manufactures:
 - 1. Kinetics Noise Control, Inc.
 - 2. Korfund
 - 3. Mason Industries, Inc.
 - 4. Vibration Eliminator Company
 - 5. Vibration Isolation
 - 6. Vibration Mountings & control
 - 7. Novia; A division of C&P
- B. Mechanical Anchor Bolts: Drilled-in and stud-wedge or female-wedge type in zinc-coated steel for interior applications and stainless steel for exterior applications. Select anchor bolts with strength required for anchor and as tested according to ASTM E488.

2.20 ADHESIVE ANCHOR BOLTS

- A. Manufactures:
 - 1. Kinetics Noise Control, Inc.
 - 2. Korfund
 - 3. Mason Industries, Inc.
 - 4. Vibration Eliminator Company
 - 5. Vibration Isolation
 - 6. Vibration Mountings & control
 - 7. Novia; A division of C&P
- B. Adhesive Anchor Bolts: Drilled-in and capsule anchor system containing PVC or urethane methacrylate-based resin and accelerator, or injected polymer or hybrid mortar adhesive. Provide anchor bolts and hardware with zinc-coated steel for interior applications and stainless steel for exterior applications. Select anchor bolts with strength required for anchor and as tested according to ASTM E488.

2.21 VIBRATION ISOLATION EQUIPMENT BASES

- A. Manufactures:
 - 1. Kinetics Noise Control, Inc.
 - 2. Korfund
 - 3. Mason Industries, Inc.
 - 4. Vibration Eliminator Company
 - 5. Vibration Isolation

6. Vibration Mountings & control
7. Novia; A division of C&P

B. Steel Rails: Factory-fabricated, welded, structural-steel rails.

1. Design Requirements: Lowest possible mounting height with not less than 1-inch clearance above the floor. Include equipment anchor bolts and auxiliary motor slide rails.
 - a. Include supports for suction and discharge elbows for pumps.
2. Structural Steel: Steel shapes, plates, and bars complying with ASTM A36/A36M. Rails shall have shape to accommodate supported equipment.
3. Support Brackets: Factory-welded steel brackets on frame for outrigger isolation mountings and to provide for anchor bolts and equipment support.

C. Steel Bases: Factory-fabricated, welded, structural-steel bases and rails.

1. Design Requirements: Lowest possible mounting height with not less than 1-inch clearance above the floor. Include equipment anchor bolts and auxiliary motor slide bases or rails.
 - a. Include supports for suction and discharge elbows for pumps.
2. Structural Steel: Steel shapes, plates, and bars complying with ASTM A36/A36M. Bases shall have shape to accommodate supported equipment.
3. Support Brackets: Factory-welded steel brackets on frame for outrigger isolation mountings and to provide for anchor bolts and equipment support.

D. Concrete Inertia Base: Factory-fabricated or field-fabricated, welded, structural-steel bases and rails ready for placement of cast-in-place concrete.

1. Design Requirements: Lowest possible mounting height with not less than 1-inch clearance above the floor. Include equipment anchor bolts and auxiliary motor slide bases or rails.
 - a. Include supports for suction and discharge elbows for pumps.
2. Structural Steel: Steel shapes, plates, and bars complying with ASTM A36/A36M. Bases shall have shape to accommodate supported equipment.
3. Support Brackets: Factory-welded steel brackets on frame for outrigger isolation mountings and to provide for anchor bolts and equipment support.
4. Fabrication: Fabricate steel templates to hold equipment anchor-bolt sleeves and anchors in place during placement of concrete. Obtain anchor-bolt templates from supported equipment manufacturer.

2.22 RESTRAINED ISOLATION ROOF-CURB RAILS

A. Manufactures:

1. Kinetics Noise Control, Inc.

2. Korfund
 3. Mason Industries, Inc.
 4. Vibration Eliminator Company
 5. Vibration Isolation
 6. Vibration Mountings & control
 7. Novia; A division of C&P
- B. Description: Factory-assembled, fully enclosed, insulated, air- and watertight curb rail designed to resiliently support equipment and to withstand seismic and wind forces.
- C. Upper Frame: The upper frame shall provide continuous support for equipment and shall be captive to resiliently resist seismic and wind forces.
- D. Lower Support Assembly: The lower support assembly shall be formed sheet metal section containing adjustable and removable steel springs that support the upper frame. The lower support assembly shall have a means for attaching to building structure and a wood nailer for attaching roof materials, and shall be insulated with a minimum of **2 inches** of rigid, glass-fiber insulation on inside of assembly. Adjustable, restrained-spring isolators shall be mounted on elastomeric vibration isolation pads and shall have access ports, for level adjustment, with removable waterproof covers at all isolator locations. Isolators shall be located so they are accessible for adjustment at any time during the life of the installation without interfering with the integrity of the roof.
- E. Snubber Bushings: All-directional, elastomeric snubber bushings at least **1/4 inch** thick.
- F. Water Seal: Galvanized sheet metal with EPDM seals at corners, attached to upper support frame, extending down past wood nailer of lower support assembly, and counterflashed over roof materials.

PART 3 - EXECUTION

3.1 EXAMINATION

- A. Examine areas and equipment to receive vibration isolation and seismic and wind control devices for compliance with requirements for installation tolerances and other conditions affecting performance of the Work.
- B. Examine roughing-in of reinforcement and cast-in-place anchors to verify actual locations before installation.
- C. Proceed with installation only after unsatisfactory conditions have been corrected.

3.2 APPLICATIONS

- A. Multiple Pipe Supports: Secure pipes to trapeze member with clamps approved for application by an evaluation service member of ICC-ES.

- B. Hanger-Rod Stiffeners: Install hanger-rod stiffeners where indicated or scheduled on Drawings to receive them and where required to prevent buckling of hanger rods due to seismic forces.
- C. Strength of Support and Seismic-Restraint Assemblies: Where not indicated, select sizes of components so strength is adequate to carry present and future static and seismic loads within specified loading limits.

3.3 VIBRATION CONTROL AND SEISMIC-RESTRAINT DEVICE INSTALLATION

- A. Coordinate the location of embedded connection hardware with supported equipment attachment and mounting points and with requirements for concrete reinforcement and formwork specified in Section 033000 "Cast-in-Place Concrete."
- B. Installation of vibration isolators must not cause any change of position of equipment, piping, or ductwork resulting in stresses or misalignment.
- C. Comply with requirements in Section 077200 "Roof Accessories" for installation of roof curbs, equipment supports, and roof penetrations.
- D. Equipment Restraints:
 - 1. Install seismic snubbers on HVAC equipment mounted on vibration isolators. Locate snubbers as close as possible to vibration isolators and bolt to equipment base and supporting structure.
 - 2. Install resilient bolt isolation washers on equipment anchor bolts where clearance between anchor and adjacent surface exceeds 0.125 inch.
 - 3. Install seismic-restraint devices using methods approved by an evaluation service member of ICC-ES that provides required submittals for component.
- E. Piping Restraints:
 - 1. Comply with requirements in MSS SP-127.
 - 2. Space lateral supports a maximum of 40 feet o.c., and longitudinal supports a maximum of 80 feet o.c.
 - 3. Brace a change of direction longer than 12 feet.
- F. Install cables so they do not bend across edges of adjacent equipment or building structure.
- G. Install seismic-restraint devices using methods approved by an evaluation service member of ICC-ES that provides required submittals for component.
- H. Install bushing assemblies for anchor bolts for floor-mounted equipment, arranged to provide resilient media between anchor bolt and mounting hole in concrete base.
- I. Install bushing assemblies for mounting bolts for wall-mounted equipment, arranged to provide resilient media where equipment or equipment-mounting channels are attached to wall.
- J. Attachment to Structure: If specific attachment is not indicated, anchor bracing to structure at flanges of beams, at upper truss chords of bar joists, or at concrete members.

K. Drilled-in Anchors:

1. Identify position of reinforcing steel and other embedded items prior to drilling holes for anchors. Do not damage existing reinforcing or embedded items during coring or drilling. Notify the structural engineer if reinforcing steel or other embedded items are encountered during drilling. Locate and avoid prestressed tendons, electrical and telecommunications conduit, and gas lines.
2. Do not drill holes in concrete or masonry until concrete, mortar, or grout has achieved full design strength.
3. Wedge Anchors: Protect threads from damage during anchor installation. Heavy-duty sleeve anchors shall be installed with sleeve fully engaged in the structural element to which anchor is to be fastened.
4. Adhesive Anchors: Clean holes to remove loose material and drilling dust prior to installation of adhesive. Place adhesive in holes proceeding from the bottom of the hole and progressing toward the surface in such a manner as to avoid introduction of air pockets in the adhesive.
5. Set anchors to manufacturer's recommended torque, using a torque wrench.
6. Install zinc-coated steel anchors for interior and stainless-steel anchors for exterior applications.

3.4 ACCOMMODATION OF DIFFERENTIAL SEISMIC MOTION

- A. Install flexible connections in piping where they cross seismic joints, where adjacent sections or branches are supported by different structural elements, and where the connections terminate with connection to equipment that is anchored to a different structural element from the one supporting the connections as they approach equipment. Comply with requirements in Section 232113 "Hydronic Piping" for piping flexible connections.

3.5 FIELD QUALITY CONTROL

- A. Testing Agency: Engage a qualified testing agency to perform tests and inspections.
- B. Perform tests and inspections.
- C. Tests and Inspections:
 1. Provide evidence of recent calibration of test equipment by a testing agency acceptable to authorities having jurisdiction.
 2. Schedule test with Owner, through Architect, before connecting anchorage device to restrained component (unless postconnection testing has been approved), and with at least seven days' advance notice.
 3. Obtain Architect's approval before transmitting test loads to structure. Provide temporary load-spreading members.
 4. Test at least four of each type and size of installed anchors and fasteners selected by Architect.
 5. Test to 90 percent of rated proof load of device.
 6. Measure isolator restraint clearance.
 7. Measure isolator deflection.

8. Verify snubber minimum clearances.
9. Test and adjust restrained-air-spring isolator controls and safeties.

D. Remove and replace malfunctioning units and retest as specified above.

E. Prepare test and inspection reports.

3.6 ADJUSTING

A. Adjust isolators after piping system is at operating weight.

B. Adjust limit stops on restrained-spring isolators to mount equipment at normal operating height. After equipment installation is complete, adjust limit stops so they are out of contact during normal operation.

3.7 AIR-SPRING ISOLATOR INSTALLATION

A. Independent Isolator Installation:

1. Install tank valve into each air isolator.
2. Inflate each isolator to height and pressure specified on Drawings.

B. Pressure-Regulated Isolator Installation:

1. Coordinate the constant pressure-regulated air supply to air springs with the requirements for piping and connections specified in Section 221513 "General-Service Compressed-Air Piping."
2. Connect all pressure regulators to a single dry, filtered constant air supply.
3. Inflate isolators to height and / or pressure specified on Drawings.

3.8 VIBRATION ISOLATION EQUIPMENT BASES INSTALLATION

A. Coordinate the location of embedded connection hardware with supported equipment attachment and mounting points and with requirements for concrete reinforcement and formwork specified in Section 033000 "Cast-in-Place Concrete."

END OF SECTION 230548

SECTION 230553 - IDENTIFICATION FOR HVAC PIPING AND EQUIPMENT

PART 1 - GENERAL

1.1 RELATED DOCUMENTS*)

- A. Drawings and general provisions of the Contract, including General and Supplementary Conditions and Division 01 Specification Sections, apply to this Section.

1.2 SUMMARY

- A. Section Includes:
 - 1. Equipment labels.
 - 2. Warning signs and labels.
 - 3. Pipe labels.
 - 4. Duct labels.
 - 5. Stencils.
 - 6. Valve tags.
 - 7. Warning tags.

1.3 SUBMITTALS

- A. Product Data: For each type of product indicated.
- B. Samples: For color, letter style, and graphic representation required for each identification material and device.
- C. Equipment Label Schedule: Include a listing of all equipment to be labeled with the proposed content for each label.
- D. Valve numbering scheme.
- E. Valve Schedules: For each piping system to include in maintenance manuals.

1.4 COORDINATION

- A. Coordinate installation of identifying devices with completion of covering and painting of surfaces where devices are to be applied.
- B. Coordinate installation of identifying devices with locations of access panels and doors.
- C. Install identifying devices before installing acoustical ceilings and similar concealment.

PART 2 - PRODUCTS

2.1 EQUIPMENT LABELS

A. Metal Labels for Equipment:

1. Material and Thickness: Brass, 0.032-inch Stainless steel, 0.025-inch Aluminum, 0.032-inch or anodized aluminum, 0.032-inch minimum thickness, and having predrilled or stamped holes for attachment hardware.
2. Minimum Label Size: Length and width vary for required label content, but not less than 2-1/2 by 3/4 inch.
3. Minimum Letter Size: 1/4 inch for name of units if viewing distance is less than 24 inches, 1/2 inch for viewing distances up to 72 inches, and proportionately larger lettering for greater viewing distances. Include secondary lettering two-thirds to three-fourths the size of principal lettering.
4. Fasteners: Stainless-steel self-tapping screws.
5. Adhesive: Contact-type permanent adhesive, compatible with label and with substrate.

B. Plastic Labels for Equipment:

1. Material and Thickness: Multilayer, multicolor, plastic labels for mechanical engraving, 1/8 inch thick, and having predrilled holes for attachment hardware.
2. Letter Color: White.
3. Background Color: Black.
4. Maximum Temperature: Able to withstand temperatures up to 160 deg F.
5. Minimum Label Size: Length and width vary for required label content, but not less than 2-1/2 by 3/4 inch.
6. Minimum Letter Size: 1/4 inch for name of units if viewing distance is less than 24 inches, 1/2 inch for viewing distances up to 72 inches, and proportionately larger lettering for greater viewing distances. Include secondary lettering two-thirds to three-fourths the size of principal lettering.
7. Fasteners: Stainless-steel self-tapping screws.
8. Adhesive: Contact-type permanent adhesive, compatible with label and with substrate.

C. Label Content: Include equipment's Drawing designation or unique equipment number, Drawing numbers where equipment is indicated (plans, details, and schedules), plus the Specification Section number and title where equipment is specified.

D. Equipment Label Schedule: For each item of equipment to be labeled, on 8-1/2-by-11-inch (A4) bond paper. Tabulate equipment identification number and identify Drawing numbers where equipment is indicated (plans, details, and schedules), plus the Specification Section number and title where equipment is specified. Equipment schedule shall be included in operation and maintenance data.

2.2 WARNING SIGNS AND LABELS

A. Material and Thickness: Multilayer, multicolor, plastic labels for mechanical engraving, 1/16 inch 1/8 inch thick, and having predrilled holes for attachment hardware.

- B. Letter Color: Blue.
- C. Background Color: Red.
- D. Maximum Temperature: Able to withstand temperatures up to 160 deg F.
- E. Minimum Label Size: Length and width vary for required label content, but not less than 2-1/2 by 3/4 inch.
- F. Minimum Letter Size: 1/4 inch for name of units if viewing distance is less than 24 inches, 1/2 inch for viewing distances up to 72 inches, and proportionately larger lettering for greater viewing distances. Include secondary lettering two-thirds to three-fourths the size of principal lettering.
- G. Fasteners: Stainless-steel self-tapping screws.
- H. Adhesive: Contact-type permanent adhesive, compatible with label and with substrate.
- I. Label Content: Include caution and warning information, plus emergency notification instructions.

2.3 PIPE LABELS

- A. General Requirements for Manufactured Pipe Labels: Preprinted, color-coded, with lettering indicating service, and showing flow direction.
- B. Pretensioned Pipe Labels: Precoiled, semirigid plastic formed to cover full circumference of pipe and to attach to pipe without fasteners or adhesive.
- C. Self-Adhesive Pipe Labels: Printed plastic with contact-type, permanent-adhesive backing.
- D. Pipe Label Contents: Include identification of piping service using same designations or abbreviations as used on Drawings, pipe size, and an arrow indicating flow direction.
 - 1. Flow-Direction Arrows: Integral with piping system service lettering to accommodate both directions, or as separate unit on each pipe label to indicate flow direction.
 - 2. Lettering Size: At least 1-1/2 inches high.

2.4 DUCT LABELS

- A. Material and Thickness: Multilayer, multicolor, plastic labels for mechanical engraving, 1/8 inch thick, and having predrilled holes for attachment hardware.
- B. Letter Color: Black.
- C. Background Color: White.
- D. Maximum Temperature: Able to withstand temperatures up to 160 deg F.

- E. Minimum Label Size: Length and width vary for required label content, but not less than 2-1/2 by 3/4 inch.
- F. Minimum Letter Size: 1/4 inch for name of units if viewing distance is less than 24 inches, 1/2 inch for viewing distances up to 72 inches, and proportionately larger lettering for greater viewing distances. Include secondary lettering two-thirds to three-fourths the size of principal lettering.
- G. Fasteners: Stainless-steel self-tapping screws.
- H. Adhesive: Contact-type permanent adhesive, compatible with label and with substrate.
- I. Duct Label Contents: Include identification of duct service using same designations or abbreviations as used on Drawings, duct size, and an arrow indicating flow direction.
 - 1. Flow-Direction Arrows: Integral with duct system service lettering to accommodate both directions, or as separate unit on each duct label to indicate flow direction.
 - 2. Lettering Size: At least 1-1/2 inches high.

2.5 STENCILS

- A. Stencils: Prepared with letter sizes according to ASME A13.1 for piping; minimum letter height of 1-1/4 inches for ducts; and minimum letter height of 3/4 inch for access panel and door labels, equipment labels, and similar operational instructions.
 - 1. Stencil Material: Fiberboard or metal.
 - 2. Stencil Paint: Exterior, gloss, acrylic enamel black unless otherwise indicated. Paint may be in pressurized spray-can form.
 - 3. Identification Paint: Exterior, acrylic enamel in colors according to ASME A13.1 unless otherwise indicated.

2.6 VALVE TAGS

- A. Valve Tags: Stamped or engraved with 1/4-inch letters for piping system abbreviation and 1/2-inch numbers.
 - 1. Tag Material: Brass, 0.032-inch or anodized aluminum, 0.032-inch minimum thickness, and having predrilled or stamped holes for attachment hardware.
 - 2. Fasteners: Brass beaded chain; or S-hook beaded chain.
- B. Valve Schedules: For each piping system, on 8-1/2-by-11-inch (A4) bond paper. Tabulate valve number, piping system, system abbreviation (as shown on valve tag), location of valve (room or space), normal-operating position (open, closed, or modulating), and variations for identification. Mark valves for emergency shutoff and similar special uses.
 - 1. Valve-tag schedule shall be included in operation and maintenance data.

2.7 WARNING TAGS

- A. Warning Tags: Preprinted or partially preprinted, accident-prevention tags, of plasticized card stock with matte finish suitable for writing.
 - 1. Size: 3 by 5-1/4 inches minimum Approximately 4 by 7 inches.
 - 2. Fasteners: Reinforced grommet and wire or string.
 - 3. Nomenclature: Large-size primary caption such as "DANGER," "CAUTION," or "DO NOT OPERATE."
 - 4. Color: Yellow background with black lettering.

PART 3 - EXECUTION

3.1 PREPARATION

- A. Clean piping and equipment surfaces of substances that could impair bond of identification devices, including dirt, oil, grease, release agents, and incompatible primers, paints, and encapsulants.

3.2 EQUIPMENT LABEL INSTALLATION

- A. Install or permanently fasten labels on each major item of mechanical equipment.
- B. Locate equipment labels where accessible and visible.

3.3 PIPE LABEL INSTALLATION

- A. Piping Color-Coding: Painting of piping is specified in Division 09 Section "Interior Painting "
- B. Stenciled Pipe Label Option: Stenciled labels may be provided instead of manufactured pipe labels, at Installer's option. Install stenciled pipe labels, complying with ASME A13.1, on each piping system.
 - 1. Identification Paint: Use for contrasting background.
 - 2. Stencil Paint: Use for pipe marking.
- C. Locate pipe labels where piping is exposed or above accessible ceilings in finished spaces; machine rooms; accessible maintenance spaces such as shafts, tunnels, and plenums; and exterior exposed locations as follows:
 - 1. Near each valve and control device.
 - 2. Near each branch connection, excluding short takeoffs for fixtures and terminal units. Where flow pattern is not obvious, mark each pipe at branch.
 - 3. Near penetrations through walls, floors, ceilings, and inaccessible enclosures.
 - 4. At access doors, manholes, and similar access points that permit view of concealed piping.

5. Near major equipment items and other points of origination and termination.
6. Spaced at maximum intervals of 50 feet along each run. Reduce intervals to 25 feet in areas of congested piping and equipment.

D. Pipe Label Color Schedule:

1. Chilled-Water Piping:
 - a. Background Color: Black.
 - b. Letter Color: White.
2. Condenser-Water Piping:
 - a. Background Color: Black.
 - b. Letter Color: White.
3. Heating Water Piping:
 - a. Background Color: Black.
 - b. Letter Color: White.
4. Refrigerant Piping:
 - a. Background Color: Black.
 - b. Letter Color: White.
5. Low-Pressure Steam Piping:
 - a. Background Color: Black.
 - b. Letter Color: White.
6. High-Pressure Steam Piping:
 - a. Background Color: Black.
 - b. Letter Color: White.
7. Steam Condensate Piping:
 - a. Background Color: Black.
 - b. Letter Color: White.

3.4 DUCT LABEL INSTALLATION

- A. Install self-adhesive duct labels with permanent adhesive on air ducts in the following color codes:
 1. Blue: For cold-air supply ducts.
 2. Yellow: For hot-air supply ducts.
 3. Green: For exhaust-, outside-, relief-, return-, and mixed-air ducts.
 4. ASME A13.1 Colors and Designs: For hazardous material exhaust.

- B. Stenciled Duct Label Option: Stenciled labels, showing service and flow direction, may be provided instead of plastic-laminated duct labels, at Installer's option, if lettering larger than 1 inch high is needed for proper identification because of distance from normal location of required identification.
- C. Locate labels near points where ducts enter into concealed spaces and at maximum intervals of 50 feet in each space where ducts are exposed or concealed by removable ceiling system.

3.5 VALVE-TAG INSTALLATION

- A. Install tags on valves and control devices in piping systems, except check valves; valves within factory-fabricated equipment units; shutoff valves; faucets; convenience and lawn-watering hose connections; and HVAC terminal devices and similar roughing-in connections of end-use fixtures and units. List tagged valves in a valve schedule.
- B. Valve-Tag Application Schedule: Tag valves according to size, shape, and color scheme and with captions similar to those indicated in the following subparagraphs:

1. Valve-Tag Size and Shape:

- a. Chilled Water: 1-1/2 inches square.
- b. Condenser Water: 1-1/2 inches square.
- c. Refrigerant: 1-1/2 inches square.
- d. Hot Water: 1-1/2 inches square.
- e. Gas: 1-1/2 inches square.
- f. Low-Pressure Steam: 1-1/2 inches square.
- g. High-Pressure Steam: 1-1/2 inches square.
- h. Steam Condensate: 1-1/2 inches square.

2. Valve-Tag Color:

- a. Chilled Water: Natural.
- b. Condenser Water: Natural.
- c. Refrigerant: Natural.
- d. Hot Water: Natural.
- e. Gas: Natural.
- f. Low-Pressure Steam: Natural.
- g. High-Pressure Steam: Natural.
- h. Steam Condensate: Natural.

3. Letter Color:

- a. Chilled Water: Black.
- b. Condenser Water: Black.
- c. Refrigerant: Black.
- d. Hot Water: Black.
- e. Gas: Black.
- f. Low-Pressure Steam: Black.
- g. High-Pressure Steam: Black.

- h. Steam Condensate: Black.

3.6 WARNING-TAG INSTALLATION

- A. Write required message on, and attach warning tags to, equipment and other items where required.

END OF SECTION 230553

SECTION 230593 - TESTING, ADJUSTING, AND BALANCING FOR HVAC

PART 1 - GENERAL

1.1 RELATED DOCUMENTS

- A. Drawings and general provisions of the Contract, including General and Supplementary Conditions and Division 01 Specification Sections, apply to this Section.

1.2 SUMMARY

- A. Section Includes:
 - 1. Balancing Air Systems:
 - a. Constant-volume air systems.
 - b. Dual-duct systems.
 - c. Variable-air-volume systems.
 - d. Multizone systems.
 - e. Induction-unit systems.
 - 2. Balancing Hydronic Piping Systems:
 - a. Constant-flow hydronic systems.
 - b. Variable-flow hydronic systems.
 - c. Primary-secondary hydronic systems.

1.3 DEFINITIONS

- A. AABC: Associated Air Balance Council.
- B. NEBB: National Environmental Balancing Bureau.
- C. TAB: Testing, adjusting, and balancing.
- D. TABB: Testing, Adjusting, and Balancing Bureau.
- E. TAB Specialist: An entity engaged to perform TAB Work.

1.4 SUBMITTALS

- A. Qualification Data: Within 15 days of Contractor's Notice to Proceed, submit documentation that the TAB contractor and this Project's TAB team members meet the qualifications specified in "Quality Assurance" Article.

- B. Contract Documents Examination Report: Within 15 days of Contractor's Notice to Proceed, submit the Contract Documents review report as specified in Part 3.
- C. Strategies and Procedures Plan: Within 30 days of Contractor's Notice to Proceed, submit TAB strategies and step-by-step procedures as specified in "Preparation" Article.
- D. Certified TAB reports.
- E. Sample report forms.
- F. Instrument calibration reports, to include the following:
 - 1. Instrument type and make.
 - 2. Serial number.
 - 3. Application.
 - 4. Dates of use.
 - 5. Dates of calibration.

1.5 QUALITY ASSURANCE

- A. TAB Contractor Qualifications: Engage a TAB entity certified by AABC or TABB.
 - 1. TAB Field Supervisor: Employee of the TAB contractor and certified by AABC or TABB.
 - 2. TAB Technician: Employee of the TAB contractor and who is certified by AABC or TABB as a TAB technician.
- B. TAB Conference: Meet with Construction Manager on approval of the TAB strategies and procedures plan to develop a mutual understanding of the details. Require the participation of the TAB field supervisor and technicians. Provide seven days' advance notice of scheduled meeting time and location.
 - 1. Agenda Items:
 - a. The Contract Documents examination report.
 - b. The TAB plan.
 - c. Coordination and cooperation of trades and subcontractors.
 - d. Coordination of documentation and communication flow.
- C. Certify TAB field data reports and perform the following:
 - 1. Review field data reports to validate accuracy of data and to prepare certified TAB reports.
 - 2. Certify that the TAB team complied with the approved TAB plan and the procedures specified and referenced in this Specification.
- D. TAB Report Forms: Use standard TAB contractor's forms approved by Construction Manager.

- E. Instrumentation Type, Quantity, Accuracy, and Calibration: As described in ASHRAE 111, Section 5, "Instrumentation."

1.6 PROJECT CONDITIONS

- A. Full Owner Occupancy: Owner will occupy the site and existing building during entire TAB period. Cooperate with Owner during TAB operations to minimize conflicts with Owner's operations.
- B. Partial Owner Occupancy: Owner may occupy completed areas of building before Substantial Completion. Cooperate with Owner during TAB operations to minimize conflicts with Owner's operations.

1.7 COORDINATION

- A. Notice: Provide seven days' advance notice for each test. Include scheduled test dates and times.
- B. Perform TAB after leakage and pressure tests on air and water distribution systems have been satisfactorily completed.

PART 2 - PRODUCTS (Not Applicable)

PART 3 - EXECUTION

3.1 TAB SPECIALISTS

- A. Subject to compliance with requirements, available TAB contractors that may be engaged include, but are not limited to, the following:

3.2 ACCESS REQUIREMENTS

- A. It is the testing and balancing contractor's responsibility the project site prior to taking any measurements to confirm there is enough access to make each and every measurement. "Access Not Available" and similar comments noted in the testing and balancing report are not acceptable.
- B. It shall be the responsibility of the general and mechanical contractor to provide access to the system components that will be tested and balanced again, with no additional charges to the University.

3.3 PRESSURE PROFILES

- A. Static pressure profiles are required for air handling units.

- B. Static pressure profiles are required for ductwork systems.

3.4 EXAMINATION

- A. Examine the Contract Documents to become familiar with Project requirements and to discover conditions in systems' designs that may preclude proper TAB of systems and equipment.
- B. Examine systems for installed balancing devices, such as test ports, gage cocks, thermometer wells, flow-control devices, balancing valves and fittings, and manual volume dampers. Verify that locations of these balancing devices are accessible.
- C. Examine the approved submittals for HVAC systems and equipment.
- D. Examine design data including HVAC system descriptions, statements of design assumptions for environmental conditions and systems' output, and statements of philosophies and assumptions about HVAC system and equipment controls.
- E. Examine ceiling plenums and underfloor air plenums used for supply, return, or relief air to verify that they meet the leakage class of connected ducts as specified in Division 23 Section "Metal Ducts" and are properly separated from adjacent areas. Verify that penetrations in plenum walls are sealed and fire-stopped if required.
- F. Examine equipment performance data including fan and pump curves.
 - 1. Relate performance data to Project conditions and requirements, including system effects that can create undesired or unpredicted conditions that cause reduced capacities in all or part of a system.
 - 2. Calculate system-effect factors to reduce performance ratings of HVAC equipment when installed under conditions different from the conditions used to rate equipment performance. To calculate system effects for air systems, use tables and charts found in AMCA 201, "Fans and Systems," or in SMACNA's "HVAC Systems - Duct Design." Compare results with the design data and installed conditions.
- G. Examine system and equipment installations and verify that field quality-control testing, cleaning, and adjusting specified in individual Sections have been performed.
- H. Examine test reports specified in individual system and equipment Sections.
- I. Examine HVAC equipment and filters and verify that bearings are greased, belts are aligned and tight, and equipment with functioning controls is ready for operation.
- J. Examine terminal units, such as variable-air-volume boxes, and verify that they are accessible and their controls are connected and functioning.
- K. Examine strainers. Verify that startup screens are replaced by permanent screens with indicated perforations.
- L. Examine three-way valves for proper installation for their intended function of diverting or mixing fluid flows.

- M. Examine heat-transfer coils for correct piping connections and for clean and straight fins.
- N. Examine system pumps to ensure absence of entrained air in the suction piping.
- O. Examine operating safety interlocks and controls on HVAC equipment.
- P. Report deficiencies discovered before and during performance of TAB procedures. Observe and record system reactions to changes in conditions. Record default set points if different from indicated values.

3.5 PREPARATION

- A. Prepare a TAB plan that includes strategies and step-by-step procedures.
- B. Complete system-readiness checks and prepare reports. Verify the following:
 - 1. Permanent electrical-power wiring is complete.
 - 2. Hydronic systems are filled, clean, and free of air.
 - 3. Automatic temperature-control systems are operational.
 - 4. Equipment and duct access doors are securely closed.
 - 5. Balance, smoke, and fire dampers are open.
 - 6. Isolating and balancing valves are open and control valves are operational.
 - 7. Ceilings are installed in critical areas where air-pattern adjustments are required and access to balancing devices is provided.
 - 8. Windows and doors can be closed so indicated conditions for system operations can be met.

3.6 GENERAL PROCEDURES FOR TESTING AND BALANCING

- A. Perform testing and balancing procedures on each system according to the procedures contained in AABC's "National Standards for Total System Balance" and in this Section.
 - 1. Comply with requirements in ASHRAE 62.1-2004, Section 7.2.2, "Air Balancing."
- B. Cut insulation, ducts, pipes, and equipment cabinets for installation of test probes to the minimum extent necessary for TAB procedures.
 - 1. After testing and balancing, patch probe holes in ducts with same material and thickness as used to construct ducts.
 - 2. After testing and balancing, install test ports and duct access doors that comply with requirements in Division 23 Section "Air Duct Accessories."
 - 3. Install and join new insulation that matches removed materials. Restore insulation, coverings, vapor barrier, and finish according to Division 23 Section "HVAC Insulation."
- C. Test port

1. Galvanized test port with gasket to seal at penetration Nominal 2 ½" tall with 5/8" test port with threaded steel cap.
 2. Basis of design Ventlok 699-2 Instrument Test Hole.
- D. Mark equipment and balancing devices, including damper-control positions, valve position indicators, fan-speed-control levers, and similar controls and devices, with paint or other suitable, permanent identification material to show final settings.
- E. Take and report testing and balancing measurements in inch-pound (IP) units.

3.7 GENERAL PROCEDURES FOR BALANCING AIR SYSTEMS

- A. Prepare test reports for both fans and outlets. Obtain manufacturer's outlet factors and recommended testing procedures. Crosscheck the summation of required outlet volumes with required fan volumes.
- B. Prepare schematic diagrams of systems' "as-built" duct layouts.
- C. For variable-air-volume systems, develop a plan to simulate diversity.
- D. Determine the best locations in main and branch ducts for accurate duct-airflow measurements.
- E. Check airflow patterns from the outdoor-air louvers and dampers and the return- and exhaust-air dampers through the supply-fan discharge and mixing dampers.
- F. Locate start-stop and disconnect switches, electrical interlocks, and motor starters.
- G. Verify that motor starters are equipped with properly sized thermal protection.
- H. Check dampers for proper position to achieve desired airflow path.
- I. Check for airflow blockages.
- J. Check condensate drains for proper connections and functioning.
- K. Check for proper sealing of air-handling-unit components.
- L. Verify that air duct system is sealed as specified in Division 23 Section "Metal Ducts."

3.8 PROCEDURES FOR CONSTANT-VOLUME AIR SYSTEMS

- A. Adjust fans to deliver total indicated airflows within the maximum allowable fan speed listed by fan manufacturer.
1. Measure total airflow.

- a. Where sufficient space in ducts is unavailable for Pitot-tube traverse measurements, measure airflow at terminal outlets and inlets and calculate the total airflow.
 2. Measure fan static pressures as follows to determine actual static pressure:
 - a. Measure outlet static pressure as far downstream from the fan as practical and upstream from restrictions in ducts such as elbows and transitions.
 - b. Measure static pressure directly at the fan outlet or through the flexible connection.
 - c. Measure inlet static pressure of single-inlet fans in the inlet duct as near the fan as possible, upstream from the flexible connection, and downstream from duct restrictions.
 - d. Measure inlet static pressure of double-inlet fans through the wall of the plenum that houses the fan.
 3. Measure static pressure across each component that makes up an air-handling unit, rooftop unit, and other air-handling and -treating equipment.
 - a. Report the cleanliness status of filters and the time static pressures are measured.
 4. Measure static pressures entering and leaving other devices, such as sound traps, heat-recovery equipment, and air washers, under final balanced conditions.
 5. Review Record Documents to determine variations in design static pressures versus actual static pressures. Calculate actual system-effect factors. Recommend adjustments to accommodate actual conditions.
 6. Obtain approval from Construction Manager for adjustment of fan speed higher or lower than indicated speed. Comply with requirements in Division 23 Sections for air-handling units for adjustment of fans, belts, and pulley sizes to achieve indicated air-handling-unit performance.
 7. Do not make fan-speed adjustments that result in motor overload. Consult equipment manufacturers about fan-speed safety factors. Modulate dampers and measure fan-motor amperage to ensure that no overload will occur. Measure amperage in full-cooling, full-heating, economizer, and any other operating mode to determine the maximum required brake horsepower.
- B. Adjust volume dampers for main duct, submain ducts, and major branch ducts to indicated airflows within specified tolerances.
1. Measure airflow of submain and branch ducts.
 - a. Where sufficient space in submain and branch ducts is unavailable for Pitot-tube traverse measurements, measure airflow at terminal outlets and inlets and calculate the total airflow for that zone.
 2. Measure static pressure at a point downstream from the balancing damper, and adjust volume dampers until the proper static pressure is achieved.
 3. Remeasure each submain and branch duct after all have been adjusted. Continue to adjust submain and branch ducts to indicated airflows within specified tolerances.
- C. Measure air outlets and inlets without making adjustments.

1. Measure terminal outlets using a direct-reading hood or outlet manufacturer's written instructions and calculating factors.
- D. Adjust air outlets and inlets for each space to indicated airflows within specified tolerances of indicated values. Make adjustments using branch volume dampers rather than extractors and the dampers at air terminals.
 1. Adjust each outlet in same room or space to within specified tolerances of indicated quantities without generating noise levels above the limitations prescribed by the Contract Documents.
 2. Adjust patterns of adjustable outlets for proper distribution without drafts.
- E. Where Pressure Independent Laboratory air terminal units are installed verify calibration at Max and Min airflow along with factory trained technician. Support programming of calibration factors into the building automation system.

3.9 PROCEDURES FOR DUAL-DUCT SYSTEMS

- A. Verify that the cooling coil is capable of full-system airflow, and set mixing boxes at full-cold airflow position for fan volume.
- B. Measure static pressure in both hot and cold ducts at the end of the longest duct run to determine that sufficient static pressure exists to operate controls of mixing boxes and to overcome resistance in the ducts and outlets downstream from mixing boxes.
 1. If insufficient static pressure exists, increase airflow at the fan.
- C. Test and adjust the constant-volume mixing boxes as follows:
 1. Verify both hot and cold operations by adjusting the thermostat and observing changes in air temperature and volume.
 2. Verify sufficient inlet static pressure before making volume adjustments.
 3. Adjust mixing boxes to indicated airflows within specified tolerances. Measure airflow by Pitot-tube traverse readings or by measuring static pressure at mixing-box taps if provided by mixing-box manufacturer.
- D. Do not overpressurize ducts.
- E. Remeasure static pressure in both hot and cold ducts at the end of the longest duct run to determine that sufficient static pressure exists to operate controls of mixing boxes and to overcome resistance in the ducts and outlets downstream from mixing boxes.
- F. Adjust variable-air-volume, dual-duct systems in the same way as constant-volume, dual-duct systems; adjust maximum- and minimum-airflow setting of each mixing box.

3.10 PROCEDURES FOR VARIABLE-AIR-VOLUME SYSTEMS

- A. Compensating for Diversity: When the total airflow of all terminal units is more than the indicated airflow of the fan, place a selected number of terminal units at a minimum set-point airflow with the remainder at maximum-airflow condition until the total airflow of the terminal units equals the indicated airflow of the fan. Select the reduced-airflow terminal units so they are distributed evenly among the branch ducts.
- B. Pressure-Independent, Variable-Air-Volume Systems: After the fan systems have been adjusted, adjust the variable-air-volume systems as follows:
1. Set outdoor-air dampers at minimum, and set return- and exhaust-air dampers at a position that simulates full-cooling load.
 2. Select the terminal unit that is most critical to the supply-fan airflow and static pressure. Measure static pressure. Adjust system static pressure so the entering static pressure for the critical terminal unit is not less than the sum of the terminal-unit manufacturer's recommended minimum inlet static pressure plus the static pressure needed to overcome terminal-unit discharge system losses.
 3. Measure total system airflow. Adjust to within indicated airflow.
 4. Set terminal units at maximum airflow and adjust controller or regulator to deliver the designed maximum airflow. Use terminal-unit manufacturer's written instructions to make this adjustment. When total airflow is correct, balance the air outlets downstream from terminal units the same as described for constant-volume air systems.
 5. Set terminal units at minimum airflow and adjust controller or regulator to deliver the designed minimum airflow. Check air outlets for a proportional reduction in airflow the same as described for constant-volume air systems.
 - a. If air outlets are out of balance at minimum airflow, report the condition but leave outlets balanced for maximum airflow.
 6. Remeasure the return airflow to the fan while operating at maximum return airflow and minimum outdoor airflow.
 - a. Adjust the fan and balance the return-air ducts and inlets the same as described for constant-volume air systems.
 7. Measure static pressure at the most critical terminal unit and adjust the static-pressure controller at the main supply-air sensing station to ensure that adequate static pressure is maintained at the most critical unit.
 8. Record final fan-performance data.
- C. Pressure-Dependent, Variable-Air-Volume Systems without Diversity: After the fan systems have been adjusted, adjust the variable-air-volume systems as follows:
1. Balance variable-air-volume systems the same as described for constant-volume air systems.
 2. Set terminal units and supply fan at full-airflow condition.
 3. Adjust inlet dampers of each terminal unit to indicated airflow and verify operation of the static-pressure controller. When total airflow is correct, balance the air outlets downstream from terminal units the same as described for constant-volume air systems.

4. Readjust fan airflow for final maximum readings.
 5. Measure operating static pressure at the sensor that controls the supply fan if one is installed, and verify operation of the static-pressure controller.
 6. Set supply fan at minimum airflow if minimum airflow is indicated. Measure static pressure to verify that it is being maintained by the controller.
 7. Set terminal units at minimum airflow and adjust controller or regulator to deliver the designed minimum airflow. Check air outlets for a proportional reduction in airflow the same as described for constant-volume air systems.
 - a. If air outlets are out of balance at minimum airflow, report the condition but leave the outlets balanced for maximum airflow.
 8. Measure the return airflow to the fan while operating at maximum return airflow and minimum outdoor airflow.
 - a. Adjust the fan and balance the return-air ducts and inlets the same as described for constant-volume air systems.
- D. Pressure-Dependent, Variable-Air-Volume Systems with Diversity: After the fan systems have been adjusted, adjust the variable-air-volume systems as follows:
1. Set system at maximum indicated airflow by setting the required number of terminal units at minimum airflow. Select the reduced-airflow terminal units so they are distributed evenly among the branch ducts.
 2. Adjust supply fan to maximum indicated airflow with the variable-airflow controller set at maximum airflow.
 3. Set terminal units at full-airflow condition.
 4. Adjust terminal units starting at the supply-fan end of the system and continuing progressively to the end of the system. Adjust inlet dampers of each terminal unit to indicated airflow. When total airflow is correct, balance the air outlets downstream from terminal units the same as described for constant-volume air systems.
 5. Adjust terminal units for minimum airflow.
 6. Measure static pressure at the sensor.
 7. Measure the return airflow to the fan while operating at maximum return airflow and minimum outdoor airflow. Adjust the fan and balance the return-air ducts and inlets the same as described for constant-volume air systems.
- E. Where Pressure Independent Laboratory air terminal units are installed verify calibration at Max and Min airflow along with factory trained technician. Support programming of calibration factors into the building automation system.
- ### 3.11 PROCEDURES FOR MULTIZONE SYSTEMS
- A. Set unit at maximum airflow through the cooling coil.
 - B. Adjust each zone's balancing damper to achieve indicated airflow within the zone.

3.12 GENERAL PROCEDURES FOR HYDRONIC SYSTEMS

- A. Prepare test reports with pertinent design data, and number in sequence starting at pump to end of system. Check the sum of branch-circuit flows against the approved pump flow rate. Correct variations that exceed plus or minus 5 percent.
- B. Prepare schematic diagrams of systems' "as-built" piping layouts.
- C. Prepare hydronic systems for testing and balancing according to the following, in addition to the general preparation procedures specified above:
 - 1. Open all manual valves for maximum flow.
 - 2. Check liquid level in expansion tank.
 - 3. Check makeup water-station pressure gage for adequate pressure for highest vent.
 - 4. Check flow-control valves for specified sequence of operation, and set at indicated flow.
 - 5. Set differential-pressure control valves at the specified differential pressure. Do not set at fully closed position when pump is positive-displacement type unless several terminal valves are kept open.
 - 6. Set system controls so automatic valves are wide open to heat exchangers.
 - 7. Check pump-motor load. If motor is overloaded, throttle main flow-balancing device so motor nameplate rating is not exceeded.
 - 8. Check air vents for a forceful liquid flow exiting from vents when manually operated.

3.13 PROCEDURES FOR CONSTANT-FLOW HYDRONIC SYSTEMS

- A. Measure water flow at pumps. Use the following procedures except for positive-displacement pumps:
 - 1. Verify impeller size by operating the pump with the discharge valve closed. Read pressure differential across the pump. Convert pressure to head and correct for differences in gage heights. Note the point on manufacturer's pump curve at zero flow and verify that the pump has the intended impeller size.
 - a. If impeller sizes must be adjusted to achieve pump performance, obtain approval from Construction Manager and comply with requirements in Division 23 Section "Hydronic Pumps."
 - 2. Check system resistance. With all valves open, read pressure differential across the pump and mark pump manufacturer's head-capacity curve. Adjust pump discharge valve until indicated water flow is achieved.
 - a. Monitor motor performance during procedures and do not operate motors in overload conditions.
 - 3. Verify pump-motor brake horsepower. Calculate the intended brake horsepower for the system based on pump manufacturer's performance data. Compare calculated brake horsepower with nameplate data on the pump motor. Report conditions where actual amperage exceeds motor nameplate amperage.
 - 4. Report flow rates that are not within plus or minus 10 percent of design.

- B. Measure flow at all automatic flow control valves to verify that valves are functioning as designed.
- C. Measure flow at all pressure-independent characterized control valves, with valves in fully open position, to verify that valves are functioning as designed.
- D. Set calibrated balancing valves, if installed, at calculated presettings.
- E. Measure flow at all stations and adjust, where necessary, to obtain first balance.
 - 1. System components that have Cv rating or an accurately cataloged flow-pressure-drop relationship may be used as a flow-indicating device.
- F. Measure flow at main balancing station and set main balancing device to achieve flow that is 5 percent greater than indicated flow.
- G. Adjust balancing stations to within specified tolerances of indicated flow rate as follows:
 - 1. Determine the balancing station with the highest percentage over indicated flow.
 - 2. Adjust each station in turn, beginning with the station with the highest percentage over indicated flow and proceeding to the station with the lowest percentage over indicated flow.
 - 3. Record settings and mark balancing devices.
- H. Measure pump flow rate and make final measurements of pump amperage, voltage, rpm, pump heads, and systems' pressures and temperatures including outdoor-air temperature.
- I. Measure the differential-pressure-control-valve settings existing at the conclusion of balancing.
- J. Check settings and operation of each safety valve. Record settings.

3.14 PROCEDURES FOR VARIABLE-FLOW HYDRONIC SYSTEMS

- A. Balance systems with automatic two- and three-way control valves by setting systems at maximum flow through heat-exchange terminals and proceed as specified above for hydronic systems.

3.15 PROCEDURES FOR PRIMARY-SECONDARY HYDRONIC SYSTEMS

- A. Balance the primary circuit flow first and then balance the secondary circuits.

3.16 PROCEDURES FOR STEAM SYSTEMS

- A. Measure and record upstream and downstream pressure of each piece of equipment.
- B. Measure and record upstream and downstream steam pressure of pressure-reducing valves.

- C. Check settings and operation of automatic temperature-control valves, self-contained control valves, and pressure-reducing valves. Record final settings.
- D. Check settings and operation of each safety valve. Record settings.
- E. Verify the operation of each steam trap.

3.17 PROCEDURES FOR HEAT EXCHANGERS

- A. Measure water flow through all circuits.
- B. Adjust water flow to within specified tolerances.
- C. Measure inlet and outlet water temperatures.
- D. Measure inlet steam pressure.
- E. Check settings and operation of safety and relief valves. Record settings.

3.18 PROCEDURES FOR MOTORS

- A. Motors, 1/2 HP and Larger: Test at final balanced conditions and record the following data:
 - 1. Manufacturer's name, model number, and serial number.
 - 2. Motor horsepower rating.
 - 3. Motor rpm.
 - 4. Efficiency rating.
 - 5. Nameplate and measured voltage, each phase.
 - 6. Nameplate and measured amperage, each phase.
 - 7. Starter thermal-protection-element rating.
- B. Motors Driven by Variable-Frequency Controllers: Test for proper operation at speeds varying from minimum to maximum. Test the manual bypass of the controller to prove proper operation. Record observations including name of controller manufacturer, model number, serial number, and nameplate data.

3.19 PROCEDURES FOR CHILLERS

- A. Balance water flow through each evaporator and condenser to within specified tolerances of indicated flow with all pumps operating. With only one chiller operating in a multiple chiller installation, do not exceed the flow for the maximum tube velocity recommended by the chiller manufacturer. Measure and record the following data with each chiller operating at design conditions:
 - 1. Evaporator-water entering and leaving temperatures, pressure drop, and water flow.
 - 2. For water-cooled chillers, condenser-water entering and leaving temperatures, pressure drop, and water flow.

3. Evaporator and condenser refrigerant temperatures and pressures, using instruments furnished by chiller manufacturer.
4. Power factor if factory-installed instrumentation is furnished for measuring kilowatts.
5. Kilowatt input if factory-installed instrumentation is furnished for measuring kilowatts.
6. Capacity: Calculate in tons of cooling.
7. For air-cooled chillers, verify condenser-fan rotation and record fan and motor data including number of fans and entering- and leaving-air temperatures.

3.20 PROCEDURES FOR COOLING TOWERS

- A. Shut off makeup water for the duration of the test, and verify that makeup and blowdown systems are fully operational after tests and before leaving the equipment. Perform the following tests and record the results:
 1. Measure condenser-water flow to each cell of the cooling tower.
 2. Measure entering- and leaving-water temperatures.
 3. Measure wet- and dry-bulb temperatures of entering air.
 4. Measure wet- and dry-bulb temperatures of leaving air.
 5. Measure condenser-water flow rate recirculating through the cooling tower.
 6. Measure cooling-tower spray pump discharge pressure.
 7. Adjust water level and feed rate of makeup water system.
 8. Measure flow through bypass.

3.21 PROCEDURES FOR CONDENSING UNITS

- A. Verify proper rotation of fans.
- B. Measure entering- and leaving-air temperatures.
- C. Record compressor data.

3.22 PROCEDURES FOR BOILERS

- A. Hydronic Boilers: Measure and record entering- and leaving-water temperatures and water flow.
- B. Steam Boilers: Measure and record entering-water temperature and flow and leaving-steam pressure, temperature, and flow.

3.23 PROCEDURES FOR HEAT-TRANSFER COILS

- A. Measure, adjust, and record the following data for each water coil:
 1. Entering- and leaving-water temperature.
 2. Water flow rate.
 3. Water pressure drop.

4. Dry-bulb temperature of entering and leaving air.
5. Wet-bulb temperature of entering and leaving air for cooling coils.
6. Airflow.
7. Air pressure drop.

B. Measure, adjust, and record the following data for each electric heating coil:

1. Nameplate data.
2. Airflow.
3. Entering- and leaving-air temperature at full load.
4. Voltage and amperage input of each phase at full load and at each incremental stage.
5. Calculated kilowatt at full load.
6. Fuse or circuit-breaker rating for overload protection.

C. Measure, adjust, and record the following data for each steam coil:

1. Dry-bulb temperature of entering and leaving air.
2. Airflow.
3. Air pressure drop.
4. Inlet steam pressure.

D. Measure, adjust, and record the following data for each refrigerant coil:

1. Dry-bulb temperature of entering and leaving air.
2. Wet-bulb temperature of entering and leaving air.
3. Airflow.
4. Air pressure drop.
5. Refrigerant suction pressure and temperature.

3.24 PROCEDURES FOR TESTING, ADJUSTING, AND BALANCING EXISTING SYSTEMS

A. Perform a preconstruction inspection of existing equipment that is to remain and be reused.

1. Measure and record the operating speed, airflow, and static pressure of each fan.
2. Measure motor voltage and amperage. Compare the values to motor nameplate information.
3. Check the refrigerant charge.
4. Check the condition of filters.
5. Check the condition of coils.
6. Check the operation of the drain pan and condensate-drain trap.
7. Check bearings and other lubricated parts for proper lubrication.
8. Report on the operating condition of the equipment and the results of the measurements taken. Report deficiencies.

B. Before performing testing and balancing of existing systems, inspect existing equipment that is to remain and be reused to verify that existing equipment has been cleaned and refurbished. Verify the following:

1. New filters are installed.

2. Coils are clean and fins combed.
 3. Drain pans are clean.
 4. Fans are clean.
 5. Bearings and other parts are properly lubricated.
 6. Deficiencies noted in the preconstruction report are corrected.
- C. Perform testing and balancing of existing systems to the extent that existing systems are affected by the renovation work.
1. Compare the indicated airflow of the renovated work to the measured fan airflows, and determine the new fan speed and the face velocity of filters and coils.
 2. Verify that the indicated airflows of the renovated work result in filter and coil face velocities and fan speeds that are within the acceptable limits defined by equipment manufacturer.
 3. If calculations increase or decrease the air flow rates and water flow rates by more than 5 percent, make equipment adjustments to achieve the calculated rates. If increase or decrease is 5 percent or less, equipment adjustments are not required.
 4. Balance each air outlet.

3.25 TOLERANCES

- A. Set HVAC system's air flow rates and water flow rates within the following tolerances:
1. Supply, Return, and Exhaust Fans and Equipment with Fans: Plus or minus 10 percent.
 2. Air Outlets and Inlets: Plus or minus 10 percent
 3. Heating-Water Flow Rate: Plus or minus 10 percent
 4. Cooling-Water Flow Rate: Plus or minus 10 percent

3.26 REPORTING

- A. Initial Construction-Phase Report: Based on examination of the Contract Documents as specified in "Examination" Article, prepare a report on the adequacy of design for systems' balancing devices. Recommend changes and additions to systems' balancing devices to facilitate proper performance measuring and balancing. Recommend changes and additions to HVAC systems and general construction to allow access for performance measuring and balancing devices.
- B. Status Reports: Prepare biweekly progress reports to describe completed procedures, procedures in progress, and scheduled procedures. Include a list of deficiencies and problems found in systems being tested and balanced. Prepare a separate report for each system and each building floor for systems serving multiple floors.

3.27 FINAL REPORT

- A. General: Prepare a certified written report; tabulate and divide the report into separate sections for tested systems and balanced systems.

1. Include a certification sheet at the front of the report's binder, signed and sealed by the certified testing and balancing engineer.
 2. Include a list of instruments used for procedures, along with proof of calibration.
- B. Final Report Contents: In addition to certified field-report data, include the following:
1. Pump curves.
 2. Fan curves.
 3. Manufacturers' test data.
 4. Field test reports prepared by system and equipment installers.
 5. Other information relative to equipment performance; do not include Shop Drawings and product data.
- C. General Report Data: In addition to form titles and entries, include the following data:
1. Title page.
 2. Name and address of the TAB contractor.
 3. Project name.
 4. Project location.
 5. Architect's name and address.
 6. Engineer's name and address.
 7. Contractor's name and address.
 8. Report date.
 9. Signature of TAB supervisor who certifies the report.
 10. Table of Contents with the total number of pages defined for each section of the report. Number each page in the report.
 11. Summary of contents including the following:
 - a. Indicated versus final performance.
 - b. Notable characteristics of systems.
 - c. Description of system operation sequence if it varies from the Contract Documents.
 12. Nomenclature sheets for each item of equipment.
 13. Data for terminal units, including manufacturer's name, type, size, and fittings.
 14. Notes to explain why certain final data in the body of reports vary from indicated values.
 15. Test conditions for fans and pump performance forms including the following:
 - a. Settings for outdoor-, return-, and exhaust-air dampers.
 - b. Conditions of filters.
 - c. Cooling coil, wet- and dry-bulb conditions.
 - d. Face and bypass damper settings at coils.
 - e. Fan drive settings including settings and percentage of maximum pitch diameter.
 - f. Inlet vane settings for variable-air-volume systems.
 - g. Settings for supply-air, static-pressure controller.
 - h. Other system operating conditions that affect performance.
- D. System Diagrams: Include schematic layouts of air and hydronic distribution systems. Present each system with single-line diagram and include the following:

1. Quantities of outdoor, supply, return, and exhaust airflows.
 2. Water and steam flow rates.
 3. Duct, outlet, and inlet sizes.
 4. Pipe and valve sizes and locations.
 5. Terminal units.
 6. Balancing stations.
 7. Position of balancing devices.
- E. Air-Handling-Unit Test Reports: For air-handling units with coils, include the following:
1. Unit Data:
 - a. Unit identification.
 - b. Location.
 - c. Make and type.
 - d. Model number and unit size.
 - e. Manufacturer's serial number.
 - f. Unit arrangement and class.
 - g. Discharge arrangement.
 - h. Sheave make, size in inches (mm), and bore.
 - i. Center-to-center dimensions of sheave, and amount of adjustments in inches (mm).
 - j. Number, make, and size of belts.
 - k. Number, type, and size of filters.
 2. Motor Data:
 - a. Motor make, and frame type and size.
 - b. Horsepower and rpm.
 - c. Volts, phase, and hertz.
 - d. Full-load amperage and service factor.
 - e. Sheave make, size in inches, and bore.
 - f. Center-to-center dimensions of sheave, and amount of adjustments in inches
 3. Test Data (Indicated and Actual Values):
 - a. Total air flow rate in cfm .
 - b. Total system static pressure in inches wg .
 - c. Fan rpm.
 - d. Discharge static pressure in inches wg .
 - e. Filter static-pressure differential in inches wg .
 - f. Preheat-coil static-pressure differential in inches wg .
 - g. Cooling-coil static-pressure differential in inches wg .
 - h. Heating-coil static-pressure differential in inches wg .
 - i. Outdoor airflow in cfm .
 - j. Return airflow in cfm .
 - k. Outdoor-air damper position.
 - l. Return-air damper position.
 - m. Vortex damper position.
- F. Apparatus-Coil Test Reports:

1. Coil Data:

- a. System identification.
- b. Location.
- c. Coil type.
- d. Number of rows.
- e. Fin spacing in fins per inch o.c.
- f. Make and model number.
- g. Face area in sq. ft. .
- h. Tube size in NPS .
- i. Tube and fin materials.
- j. Circuiting arrangement.

2. Test Data (Indicated and Actual Values):

- a. Air flow rate in cfm .
- b. Average face velocity in fpm.
- c. Air pressure drop in inches wg .
- d. Outdoor-air, wet- and dry-bulb temperatures in deg F.
- e. Return-air, wet- and dry-bulb temperatures in deg F.
- f. Entering-air, wet- and dry-bulb temperatures in deg F.
- g. Leaving-air, wet- and dry-bulb temperatures in deg F.
- h. Water flow rate in gpm .
- i. Water pressure differential in feet of head or psig.
- j. Entering-water temperature in deg F.
- k. Leaving-water temperature in deg F.
- l. Refrigerant expansion valve and refrigerant types.
- m. Refrigerant suction pressure in psig.
- n. Refrigerant suction temperature in deg F.
- o. Inlet steam pressure in psig.

G. Gas- and Oil-Fired Heat Apparatus Test Reports: In addition to manufacturer's factory startup equipment reports, include the following:

1. Unit Data:

- a. System identification.
- b. Location.
- c. Make and type.
- d. Model number and unit size.
- e. Manufacturer's serial number.
- f. Fuel type in input data.
- g. Output capacity in Btu/h.
- h. Ignition type.
- i. Burner-control types.
- j. Motor horsepower and rpm.
- k. Motor volts, phase, and hertz.
- l. Motor full-load amperage and service factor.
- m. Sheave make, size in inches, and bore.
- n. Center-to-center dimensions of sheave, and amount of adjustments in inches (mm).

2. Test Data (Indicated and Actual Values):
 - a. Total air flow rate in cfm .
 - b. Entering-air temperature in deg F.
 - c. Leaving-air temperature in deg F.
 - d. Air temperature differential in deg F.
 - e. Entering-air static pressure in inches wg .
 - f. Leaving-air static pressure in inches wg .
 - g. Air static-pressure differential in inches wg .
 - h. Low-fire fuel input in Btu/h.
 - i. High-fire fuel input in Btu/h.
 - j. Manifold pressure in psig).
 - k. High-temperature-limit setting in deg F.
 - l. Operating set point in Btu/h.
 - m. Motor voltage at each connection.
 - n. Motor amperage for each phase.
 - o. Heating value of fuel in Btu/h.

- H. Electric-Coil Test Reports: For electric furnaces, duct coils, and electric coils installed in central-station air-handling units, include the following:
 1. Unit Data:
 - a. System identification.
 - b. Location.
 - c. Coil identification.
 - d. Capacity in Btu/h .
 - e. Number of stages.
 - f. Connected volts, phase, and hertz.
 - g. Rated amperage.
 - h. Air flow rate in cfm .
 - i. Face area in sq. ft. .
 - j. Minimum face velocity in fpm.

 2. Test Data (Indicated and Actual Values):
 - a. Heat output in Btu/h.
 - b. Air flow rate in cfm .
 - c. Air velocity in fpm.
 - d. Entering-air temperature in deg F.
 - e. Leaving-air temperature in deg F.
 - f. Voltage at each connection.
 - g. Amperage for each phase.

- I. Fan Test Reports: For supply, return, and exhaust fans, include the following:
 1. Fan Data:
 - a. System identification.
 - b. Location.

- c. Make and type.
 - d. Model number and size.
 - e. Manufacturer's serial number.
 - f. Arrangement and class.
 - g. Sheave make, size in inches, and bore.
 - h. Center-to-center dimensions of sheave, and amount of adjustments in inches (mm).
 2. Motor Data:
 - a. Motor make, and frame type and size.
 - b. Horsepower and rpm.
 - c. Volts, phase, and hertz.
 - d. Full-load amperage and service factor.
 - e. Sheave make, size in inches, and bore.
 - f. Center-to-center dimensions of sheave, and amount of adjustments in inches (mm).
 - g. Number, make, and size of belts.
 3. Test Data (Indicated and Actual Values):
 - a. Total airflow rate in cfm.
 - b. Total system static pressure in inches wg.
 - c. Fan rpm.
 - d. Discharge static pressure in inches wg.
 - e. Suction static pressure in inches wg.
- J. Round, Flat-Oval, and Rectangular Duct Traverse Reports: Include a diagram with a grid representing the duct cross-section and record the following:
 1. Report Data:
 - a. System and air-handling-unit number.
 - b. Location and zone.
 - c. Traverse air temperature in deg F.
 - d. Duct static pressure in inches wg.
 - e. Duct size in inches.
 - f. Duct area in sq. ft. .
 - g. Indicated air flow rate in cfm.
 - h. Indicated velocity in fpm.
 - i. Actual air flow rate in cfm .
 - j. Actual average velocity in fpm.
 - k. Barometric pressure in psig.
- K. Air-Terminal-Device Reports:
 1. Unit Data:
 - a. System and air-handling unit identification.
 - b. Location and zone.
 - c. Apparatus used for test.
 - d. Area served.

- e. Make.
 - f. Number from system diagram.
 - g. Type and model number.
 - h. Size.
 - i. Effective area in sq. ft. .
 2. Test Data (Indicated and Actual Values):
 - a. Air flow rate in cfm.
 - b. Air velocity in fpm.
 - c. Preliminary air flow rate as needed in cfm .
 - d. Preliminary velocity as needed in fpm.
 - e. Final air flow rate in cfm .
 - f. Final velocity in fpm.
 - g. Space temperature in deg F.
- L. System-Coil Reports: For reheat coils and water coils of terminal units, include the following:
 1. Unit Data:
 - a. System and air-handling-unit identification.
 - b. Location and zone.
 - c. Room or riser served.
 - d. Coil make and size.
 - e. Flowmeter type.
 2. Test Data (Indicated and Actual Values):
 - a. Air flow rate in cfm .
 - b. Entering-water temperature in deg F.
 - c. Leaving-water temperature in deg F.
 - d. Water pressure drop in feet of head or psig.
 - e. Entering-air temperature in deg F.
 - f. Leaving-air temperature in deg F.
- M. Pump Test Reports: Calculate impeller size by plotting the shutoff head on pump curves and include the following:
 1. Unit Data:
 - a. Unit identification.
 - b. Location.
 - c. Service.
 - d. Make and size.
 - e. Model number and serial number.
 - f. Water flow rate in gpm.
 - g. Water pressure differential in feet of head or psig.
 - h. Required net positive suction head in feet of head or psig.
 - i. Pump rpm.
 - j. Impeller diameter in inches.

- k. Motor make and frame size.
 - l. Motor horsepower and rpm.
 - m. Voltage at each connection.
 - n. Amperage for each phase.
 - o. Full-load amperage and service factor.
 - p. Seal type.
2. Test Data (Indicated and Actual Values):
- a. Static head in feet of head or psig.
 - b. Pump shutoff pressure in feet of head or psig.
 - c. Actual impeller size in inches.
 - d. Full-open flow rate in gpm .
 - e. Full-open pressure in feet of head or psig.
 - f. Final discharge pressure in feet of head or psig.
 - g. Final suction pressure in feet of head or psig.
 - h. Final total pressure in feet of head or psig.
 - i. Final water flow rate in gpm.
 - j. Voltage at each connection.
 - k. Amperage for each phase.

N. Instrument Calibration Reports:

1. Report Data:
- a. Instrument type and make.
 - b. Serial number.
 - c. Application.
 - d. Dates of use.
 - e. Dates of calibration.

3.28 INSPECTIONS

A. Initial Inspection:

1. After testing and balancing are complete, operate each system and randomly check measurements to verify that the system is operating according to the final test and balance readings documented in the final report.
2. Check the following for each system:
 - a. Measure airflow of at least 10 percent of air outlets.
 - b. Measure water flow of at least 5 percent of terminals.
 - c. Measure room temperature at each thermostat/temperature sensor. Compare the reading to the set point.
 - d. Verify that balancing devices are marked with final balance position.
 - e. Note deviations from the Contract Documents in the final report.

B. Final Inspection:

1. After initial inspection is complete and documentation by random checks verifies that testing and balancing are complete and accurately documented in the final report, request that a final inspection be made by Construction Manager.
 2. The TAB contractor's test and balance engineer shall conduct the inspection in the presence of Construction Manager.
 3. Construction Manager shall randomly select measurements, documented in the final report, to be rechecked. Rechecking shall be limited to either 10 percent of the total measurements recorded or the extent of measurements that can be accomplished in a normal 8-hour business day.
 4. If rechecks yield measurements that differ from the measurements documented in the final report by more than the tolerances allowed, the measurements shall be noted as "FAILED."
 5. If the number of "FAILED" measurements is greater than 10 percent of the total measurements checked during the final inspection, the testing and balancing shall be considered incomplete and shall be rejected.
- C. TAB Work will be considered defective if it does not pass final inspections. If TAB Work fails, proceed as follows:
1. Recheck all measurements and make adjustments. Revise the final report and balancing device settings to include all changes; resubmit the final report and request a second final inspection.
 2. If the second final inspection also fails, Owner may contract the services of another TAB contractor to complete TAB Work according to the Contract Documents and deduct the cost of the services from the original TAB contractor's final payment.
- D. Prepare test and inspection reports.

3.29 ADDITIONAL TESTS

- A. Within 90 days of completing TAB, perform additional TAB to verify that balanced conditions are being maintained throughout and to correct unusual conditions.
- B. Seasonal Periods: If initial TAB procedures were not performed during near-peak summer and winter conditions, perform additional TAB during near-peak summer and winter conditions.

END OF SECTION 230593

SECTION 230700 - HVAC INSULATION

PART 1 - GENERAL

1.1 RELATED DOCUMENTS

- A. Drawings and general provisions of the Contract, including General and Supplementary Conditions and Division 01 Specification Sections, apply to this Section.

1.2 SUMMARY

- A. Section Includes:

1. Insulation Materials:
 - a. Cellular glass.
 - b. Flexible elastomeric.
 - c. Mineral fiber.
2. Fire-rated insulation systems.
3. Adhesives.
4. Mastics.
5. Sealants.
6. Field-applied jackets.
7. Tapes.
8. Securements.
9. Corner angles.

- B. Related Sections:

1. Division 22 Section "Plumbing Insulation."
2. Division 23 Section "Metal Ducts" for duct liners.

1.3 SUBMITTALS

- A. Product Data: For each type of product indicated. Include thermal conductivity, thickness, and jackets (both factory and field applied, if any).
- B. Shop Drawings:
 - 1. Detail application of protective shields, saddles, and inserts at hangers for each type of insulation and hanger.
 - 2. Detail attachment and covering of heat tracing inside insulation.
 - 3. Detail insulation application at pipe expansion joints for each type of insulation.
 - 4. Detail insulation application at elbows, fittings, flanges, valves, and specialties for each type of insulation.
 - 5. Detail removable insulation at piping specialties, equipment connections, and access panels.
 - 6. Detail application of field-applied jackets.
 - 7. Detail application at linkages of control devices.
 - 8. Detail field application for each equipment type.
- C. Samples: For each type of insulation and jacket indicated. Identify each Sample, describing product and intended use.
 - 1. Sample Sizes:
 - a. Preformed Pipe Insulation Materials: 12 inches long by NPS.
 - b. Sheet Form Insulation Materials: 12 inches square.
 - c. Jacket Materials for Pipe: 12 inches long by NPS 2.
 - d. Sheet Jacket Materials: 12 inches square.
 - e. Manufacturer's Color Charts: For products where color is specified, show the full range of colors available for each type of finish material.
- D. Qualification Data: For qualified Installer.
- E. Material Test Reports: From a qualified testing agency acceptable to authorities having jurisdiction indicating, interpreting, and certifying test results for compliance of insulation materials, sealers, attachments, cements, and jackets, with requirements indicated. Include dates of tests and test methods employed.
- F. Field quality-control reports.

1.4 QUALITY ASSURANCE

- A. Installer Qualifications: Skilled mechanics who have successfully completed an apprenticeship program or another craft training program certified by the Department of Labor, Bureau of Apprenticeship and Training.
- B. Fire-Test-Response Characteristics: Insulation and related materials shall have fire-test-response characteristics indicated, as determined by testing identical products per ASTM E 84, by a testing and inspecting agency acceptable to authorities having jurisdiction. Factory label insulation and jacket materials and adhesive, mastic, tapes, and cement material containers, with appropriate markings of applicable testing and inspecting agency.
 - 1. Insulation Installed Indoors: Flame-spread index of 25 or less, and smoke-developed index of 50 or less.
 - 2. Insulation Installed Outdoors: Flame-spread index of 75 or less, and smoke-developed index of 150 or less.

1.5 DELIVERY, STORAGE, AND HANDLING

- A. Packaging: Insulation material containers shall be marked by manufacturer with appropriate ASTM standard designation, type and grade, and maximum use temperature.

1.6 COORDINATION

- A. Coordinate size and location of supports, hangers, and insulation shields specified in Division 23 Section "Hangers and Supports for HVAC Piping and Equipment."
- B. Coordinate clearance requirements with piping Installer for piping insulation application, duct Installer for duct insulation application, and equipment Installer for equipment insulation application. Before preparing piping and ductwork Shop Drawings, establish and maintain clearance requirements for installation of insulation and field-applied jackets and finishes and for space required for maintenance.
- C. Coordinate installation and testing of heat tracing.

1.7 SCHEDULING

- A. Schedule insulation application after pressure testing systems and, where required, after installing and testing heat tracing. Insulation application may begin on segments that have satisfactory test results.
- B. Complete installation and concealment of plastic materials as rapidly as possible in each area of construction.

PART 2 - PRODUCTS

2.1 INSULATION MATERIALS

- A. Comply with requirements in Part 3 schedule articles for where insulating materials shall be applied.
- B. Products shall not contain asbestos, lead, mercury, or mercury compounds.
- C. Products that come in contact with stainless steel shall have a leachable chloride content of less than 50 ppm when tested according to ASTM C 871.
- D. Insulation materials for use on austenitic stainless steel shall be qualified as acceptable according to ASTM C 795.
- E. Foam insulation materials shall not use CFC or HCFC blowing agents in the manufacturing process.
- F. Cellular Glass: Inorganic, incombustible, foamed or cellulated glass with annealed, rigid, hermetically sealed cells. Factory-applied jacket requirements are specified in "Factory-Applied Jackets" Article.
 - 1. Products: Subject to compliance with requirements, provide one of the following:
 - a. Cell-U-Foam Corporation; Ultra-CUF.
 - b. Pittsburgh Corning Corporation; Foamglas Super K.
 - 2. Board Insulation: ASTM C 552, Type IV.
 - 3. Preformed Pipe Insulation with Factory-Applied ASJ-SSL: Comply with ASTM C 552, Type II, Class 2.
 - 4. Factory fabricate shapes according to ASTM C 450 and ASTM C 585.
- G. Flexible Elastomeric: Closed-cell, sponge- or expanded-rubber materials. Comply with ASTM C 534, Type I for tubular materials and Type II for sheet materials.
 - 1. Products: Subject to compliance with requirements, provide one of the following:
 - a. Aeroflex USA Inc.; Aerocel.
 - b. Armacell LLC; AP Armaflex.
 - c. RBX Corporation; Insul-Sheet 1800 and Insul-Tube 180.
- H. Mineral-Fiber Blanket Insulation: Mineral or glass fibers bonded with a thermosetting resin. Comply with ASTM C 547, Type I and ASTM C 795, Type II with factory-applied vinyl jacket. Factory-applied jacket requirements are specified in "Factory-Applied Jackets" Article.

1. Products: Subject to compliance with requirements, provide one of the following:
 - a. CertainTeed Corp.; Duct Wrap.
 - b. Johns Manville; Microlite.
 - c. Knauf Insulation; Duct Wrap.
 - d. Manson Insulation Inc.; Alley Wrap.
 - e. Owens Corning; All-Service Duct Wrap.

- I. High-Temperature, Mineral-Fiber Blanket Insulation: Mineral or glass fibers bonded with a thermosetting resin. Comply with ASTM C 553, Type V, without factory-applied jacket.
 1. Products: Subject to compliance with requirements, provide one of the following:
 - a. Johns Manville; HTB 23 Spin-Glas.
 - b. Owens Corning; High Temperature Flexible Batt Insulations.

- J. Mineral-Fiber Board Insulation: Mineral or glass fibers bonded with a thermosetting resin. Comply with ASTM C 612, Type IA or Type IB. For duct and plenum applications, provide insulation with factory-applied ASJ. For equipment applications, provide insulation with factory-applied ASJ. Factory-applied jacket requirements are specified in "Factory-Applied Jackets" Article.
 1. Products: Subject to compliance with requirements, provide one of the following:
 - a. CertainTeed Corp.; Commercial Board.
 - b. Fibrex Insulations Inc.; FBX.
 - c. Johns Manville; 800 Series Spin-Glas.
 - d. Knauf Insulation; Insulation Board.
 - e. Manson Insulation Inc.; AK Board.
 - f. Owens Corning; Fiberglas 700 Series.

- K. High-Temperature, Mineral-Fiber Board Insulation: Mineral or glass fibers bonded with a thermosetting resin. Comply with ASTM C 612, Type III, without factory-applied jacket.
 1. Products: Subject to compliance with requirements, provide one of the following:
 - a. Fibrex Insulations Inc.; FBX.
 - b. Johns Manville; 1000 Series Spin-Glas.
 - c. Owens Corning; High Temperature Industrial Board Insulations.

- d. Rock Wool Manufacturing Company; Delta Board.
 - e. Roxul Inc.; Roxul RW.
 - f. Thermafiber; Thermafiber Industrial Felt.
- L. Mineral-Fiber, Preformed Pipe Insulation:
- 1. Products: Subject to compliance with requirements, provide one of the following:
 - a. Fibrex Insulations Inc.; Coreplus 1200.
 - b. Johns Manville; Micro-Lok.
 - c. Knauf Insulation; 1000 Pipe Insulation.
 - d. Manson Insulation Inc.; Alley-K.
 - e. Owens Corning; Fiberglas Pipe Insulation.
- M. Mineral-Fiber, Pipe Insulation Wicking System: Preformed pipe insulation complying with ASTM C 547, Type I, Grade A, with absorbent cloth factory applied to the entire inside surface of preformed pipe insulation and extended through the longitudinal joint to outside surface of insulation under insulation jacket. Factory apply a white, polymer, vapor-retarder jacket with self-sealing adhesive tape seam and evaporation holes running continuously along the longitudinal seam, exposing the absorbent cloth.
- 1. Products: Subject to compliance with requirements, provide one of the following:
 - a. Knauf Insulation; Permawick Pipe Insulation.
 - b. Owens Corning; VaporWick Pipe Insulation.
- N. Mineral-Fiber, Pipe and Tank Insulation: Mineral or glass fibers bonded with a thermosetting resin. Semirigid board material with factory-applied FSK jacket complying with ASTM C 1393, Type II or Type IIIA Category 2, or with properties similar to ASTM C 612, Type IB. Nominal density is 2.5 lb/cu. ft. or more. Thermal conductivity (k-value) at 100 deg F is 0.29 Btu x in./h x sq. ft. x deg F or less. Factory-applied jacket requirements are specified in "Factory-Applied Jackets" Article.
- 1. Products: Subject to compliance with requirements, provide one of the following:
 - a. CertainTeed Corp.; CrimpWrap.
 - b. Johns Manville; MicroFlex.
 - c. Knauf Insulation; Pipe and Tank Insulation.
 - d. Manson Insulation Inc.; AK Flex.
 - e. Owens Corning; Fiberglas Pipe and Tank Insulation.

2.2 FIRE-RATED INSULATION SYSTEMS

- A. Fire-Rated Board: Structural-grade, press-molded, xonolite calcium silicate, fireproofing board suitable for operating temperatures up to 1700 deg F. Comply with ASTM C 656, Type II, Grade 6. tested and certified to provide a 1 2-hour fire rating by a NRTL acceptable to authority having jurisdiction.
 - 1. Products: Subject to compliance with requirements, provide one of the following:
 - a. Johns Manville; Super Firetemp M.
- B. Fire-Rated Blanket: High-temperature, flexible, blanket insulation with FSK jacket that is tested and certified to provide a 1 2-hour fire rating by a NRTL acceptable to authority having jurisdiction.
 - 1. Products: Subject to compliance with requirements, provide one of the following:
 - a. CertainTeed Corp.; FlameChek.
 - b. Johns Manville; Firetemp Wrap.
 - c. Nelson Firestop Products; Nelson FSB Flameshield Blanket.
 - d. Thermal Ceramics; FireMaster Duct Wrap.
 - e. 3M; Fire Barrier Wrap Products.
 - f. Unifrax Corporation; FyreWrap.
 - g. Vesuvius; PYROSCAT FP FASTR Duct Wrap.

2.3 INSULATING CEMENTS

- A. Mineral-Fiber Insulating Cement: Comply with ASTM C 195.
 - 1. Products: Subject to compliance with requirements, provide one of the following:
 - a. Insulco, Division of MFS, Inc.; Triple I.
 - b. P. K. Insulation Mfg. Co., Inc.; Super-Stik.
- B. Expanded or Exfoliated Vermiculite Insulating Cement: Comply with ASTM C 196.
 - 1. Products: Subject to compliance with requirements, provide one of the following:
 - a. P. K. Insulation Mfg. Co., Inc.; Thermal-V-Kote.
- C. Mineral-Fiber, Hydraulic-Setting Insulating and Finishing Cement: Comply with ASTM C 449/C 449M.

1. Products: Subject to compliance with requirements, provide one of the following:
 - a. Insulco, Division of MFS, Inc.; SmoothKote.
 - b. P. K. Insulation Mfg. Co., Inc.; PK No. 127, and Quik-Cote.
 - c. Rock Wool Manufacturing Company; Delta One Shot.

2.4 ADHESIVES

- A. Materials shall be compatible with insulation materials, jackets, and substrates and for bonding insulation to itself and to surfaces to be insulated, unless otherwise indicated.
- B. Calcium Silicate Adhesive: Fibrous, sodium-silicate-based adhesive with a service temperature range of 50 to 800 deg F.
 1. Products: Subject to compliance with requirements, provide one of the following:
 - a. Childers Products, Division of ITW; CP-97.
 - b. Foster Products Corporation, H. B. Fuller Company; 81-27/81-93.
 - c. Marathon Industries, Inc.; 290.
 - d. Mon-Eco Industries, Inc.; 22-30.
 - e. Vimasco Corporation; 760.
 2. For indoor applications, use adhesive that has a VOC content of 80 g/L or less when calculated according to 40 CFR 59, Subpart D (EPA Method 24).
- C. Cellular-Glass, Phenolic, Polyisocyanurate, and Polystyrene Adhesive: Solvent-based resin adhesive, with a service temperature range of minus 75 to plus 300 deg F.
 1. Products: Subject to compliance with requirements, provide one of the following:
 - a. Childers Products, Division of ITW; CP-96.
 - b. Foster Products Corporation, H. B. Fuller Company; 81-33.
 2. For indoor applications, use adhesive that has a VOC content of 50 g/L or less when calculated according to 40 CFR 59, Subpart D (EPA Method 24).
- D. Flexible Elastomeric and Polyolefin Adhesive: Comply with MIL-A-24179A, Type II, Class I.
 1. Products: Subject to compliance with requirements, provide one of the following:
 - a. Aeroflex USA Inc.; AeroSeal.
 - b. Armacell LCC; 520 Adhesive.

- c. Foster Products Corporation, H. B. Fuller Company; 85-75.
 - d. RBX Corporation; Rubatex Contact Adhesive.
 2. For indoor applications, use adhesive that has a VOC content of 50 g/L or less when calculated according to 40 CFR 59, Subpart D (EPA Method 24).
- E. Mineral-Fiber Adhesive: Comply with MIL-A-3316C, Class 2, Grade A.
 1. Products: Subject to compliance with requirements, provide one of the following:
 - a. Childers Products, Division of ITW; CP-82.
 - b. Foster Products Corporation, H. B. Fuller Company; 85-20.
 - c. ITW TACC, Division of Illinois Tool Works; S-90/80.
 - d. Marathon Industries, Inc.; 225.
 - e. Mon-Eco Industries, Inc.; 22-25.
 2. For indoor applications, use adhesive that has a VOC content of 80 g/L or less when calculated according to 40 CFR 59, Subpart D (EPA Method 24).
- F. Polystyrene Adhesive: Solvent- or water-based, synthetic resin adhesive with a service temperature range of minus 20 to plus 140 deg F.
 1. Products: Subject to compliance with requirements, provide one of the following:
 - a. Childers Products, Division of ITW; CP-96.
 - b. Foster Products Corporation, H. B. Fuller Company; 97-13.
- G. ASJ Adhesive, and FSK and PVDC Jacket Adhesive: Comply with MIL-A-3316C, Class 2, Grade A for bonding insulation jacket lap seams and joints.
 1. Products: Subject to compliance with requirements, provide one of the following:
 - a. Childers Products, Division of ITW; CP-82.
 - b. Foster Products Corporation, H. B. Fuller Company; 85-20.
 - c. ITW TACC, Division of Illinois Tool Works; S-90/80.
 - d. Marathon Industries, Inc.; 225.
 - e. Mon-Eco Industries, Inc.; 22-25.
 2. For indoor applications, use adhesive that has a VOC content of 50 g/L or less when calculated according to 40 CFR 59, Subpart D (EPA Method 24).

H. PVC Jacket Adhesive: Compatible with PVC jacket.

1. Products: Subject to compliance with requirements, provide one of the following:
 - a. Dow Chemical Company (The); 739, Dow Silicone.
 - b. Johns-Manville; Zeston Perma-Weld, CEEL-TITE Solvent Welding Adhesive.
 - c. P.I.C. Plastics, Inc.; Welding Adhesive.
 - d. Speedline Corporation; Speedline Vinyl Adhesive.
2. For indoor applications, use adhesive that has a VOC content of 50 g/L or less when calculated according to 40 CFR 59, Subpart D (EPA Method 24).

2.5 MASTICS

A. Materials shall be compatible with insulation materials, jackets, and substrates; comply with MIL-C-19565C, Type II.

1. For indoor applications, use mastics that have a VOC content of 80 g/L or less when calculated according to 40 CFR 59, Subpart D (EPA Method 24).

B. Vapor-Barrier Mastic: Water based; suitable for indoor and outdoor use on below ambient services.

1. Products: Subject to compliance with requirements, provide one of the following:
 - a. Childers Products, Division of ITW; CP-35.
 - b. Foster Products Corporation, H. B. Fuller Company; 30-90.
 - c. ITW TACC, Division of Illinois Tool Works; CB-50.
 - d. Marathon Industries, Inc.; 590.
 - e. Mon-Eco Industries, Inc.; 55-40.
 - f. Vimasco Corporation; 749.
2. Water-Vapor Permeance: ASTM E 96, Procedure B, 0.013 perm at 43-mil dry film thickness.
3. Service Temperature Range: Minus 20 to plus 180 deg F.
4. Solids Content: ASTM D 1644, 59 percent by volume and 71 percent by weight.
5. Color: White.

C. Vapor-Barrier Mastic: Solvent based; suitable for indoor use on below ambient services.

1. Products: Subject to compliance with requirements, provide one of the following:
 - a. Childers Products, Division of ITW; CP-30.
 - b. Foster Products Corporation, H. B. Fuller Company; 30-35.
 - c. ITW TACC, Division of Illinois Tool Works; CB-25.
 - d. Marathon Industries, Inc.; 501.
 - e. Mon-Eco Industries, Inc.; 55-10.
 2. Water-Vapor Permeance: ASTM F 1249, 0.05 perm at 35-mil dry film thickness.
 3. Service Temperature Range: 0 to 180 deg F.
 4. Solids Content: ASTM D 1644, 44 percent by volume and 62 percent by weight.
 5. Color: White.
- D. Vapor-Barrier Mastic: Solvent based; suitable for outdoor use on below ambient services.
1. Products: Subject to compliance with requirements, provide one of the following:
 - a. Childers Products, Division of ITW; Encacel.
 - b. Foster Products Corporation, H. B. Fuller Company; 60-95/60-96.
 - c. Marathon Industries, Inc.; 570.
 - d. Mon-Eco Industries, Inc.; 55-70.
 2. Water-Vapor Permeance: ASTM F 1249, 0.05 perm at 30-mil dry film thickness.
 3. Service Temperature Range: Minus 50 to plus 220 deg F.
 4. Solids Content: ASTM D 1644, 33 percent by volume and 46 percent by weight.
 5. Color: White.
- E. Breather Mastic: Water based; suitable for indoor and outdoor use on above ambient services.
1. Products: Subject to compliance with requirements, provide one of the following:
 - a. Childers Products, Division of ITW; CP-10.
 - b. Foster Products Corporation, H. B. Fuller Company; 35-00.
 - c. ITW TACC, Division of Illinois Tool Works; CB-05/15.
 - d. Marathon Industries, Inc.; 550.

- e. Mon-Eco Industries, Inc.; 55-50.
- f. Vimasco Corporation; WC-1/WC-5.
2. Water-Vapor Permeance: ASTM F 1249, 3 perms at 0.0625-inch dry film thickness.
3. Service Temperature Range: Minus 20 to plus 200 deg F.
4. Solids Content: 63 percent by volume and 73 percent by weight.
5. Color: White.

2.6 SEALANTS

A. Joint Sealants:

1. Joint Sealants for Cellular-Glass, Phenolic, and Polyisocyanurate Products: Subject to compliance with requirements, provide one of the following:
 - a. Childers Products, Division of ITW; CP-76.
 - b. Foster Products Corporation, H. B. Fuller Company; 30-45.
 - c. Marathon Industries, Inc.; 405.
 - d. Mon-Eco Industries, Inc.; 44-05.
 - e. Pittsburgh Corning Corporation; Pittseal 444.
 - f. Vimasco Corporation; 750.
2. Joint Sealants for Polystyrene Products: Subject to compliance with requirements, provide one of the following:
 - a. Childers Products, Division of ITW; CP-70.
 - b. Foster Products Corporation, H. B. Fuller Company; 30-45/30-46.
 - c. Marathon Industries, Inc.; 405.
 - d. Mon-Eco Industries, Inc.; 44-05.
 - e. Vimasco Corporation; 750.
3. Materials shall be compatible with insulation materials, jackets, and substrates.
4. Permanently flexible, elastomeric sealant.
5. Service Temperature Range: Minus 100 to plus 300 deg F.

6. Color: White or gray.
7. For indoor applications, use sealants that have a VOC content of 250 g/L or less when calculated according to 40 CFR 59, Subpart D (EPA Method 24).

B. ASJ Flashing Sealants, and Vinyl, PVDC, and PVC Jacket Flashing Sealants:

1. Products: Subject to compliance with requirements, provide one of the following:
 - a. Childers Products, Division of ITW; CP-76.
2. Materials shall be compatible with insulation materials, jackets, and substrates.
3. Fire- and water-resistant, flexible, elastomeric sealant.
4. Service Temperature Range: Minus 40 to plus 250 deg F.
5. Color: White.
6. For indoor applications, use sealants that have a VOC content of 250 g/L or less when calculated according to 40 CFR 59, Subpart D (EPA Method 24).

2.7 FACTORY-APPLIED JACKETS

A. Insulation system schedules indicate factory-applied jackets on various applications. When factory-applied jackets are indicated, comply with the following:

1. ASJ: White, kraft-paper, fiberglass-reinforced scrim with aluminum-foil backing; complying with ASTM C 1136, Type I.
2. ASJ-SSL: ASJ with self-sealing, pressure-sensitive, acrylic-based adhesive covered by a removable protective strip; complying with ASTM C 1136, Type I.
3. PVDC Jacket for Indoor Applications: 4-mil-thick, white PVDC biaxially oriented barrier film with a permeance at 0.02 perms when tested according to ASTM E 96 and with a flame-spread index of 5 and a smoke-developed index of 20 when tested according to ASTM E 84.
 - a. Products: Subject to compliance with requirements, provide one of the following:
 - 1) Dow Chemical Company (The); Saran 540 Vapor Retarder Film and Saran 560 Vapor Retarder Film.
4. PVDC Jacket for Outdoor Applications: 6-mil-thick, white PVDC biaxially oriented barrier film with a permeance at 0.01 perms when tested according to ASTM E 96 and with a flame-spread index of 5 and a smoke-developed index of 25 when tested according to ASTM E 84.
 - a. Products: Subject to compliance with requirements, provide one of the following:

- 1) Dow Chemical Company (The); Saran 540 Vapor Retarder Film and Saran 560 Vapor Retarder Film.
5. PVDC-SSL Jacket: PVDC jacket with a self-sealing, pressure-sensitive, acrylic-based adhesive covered by a removable protective strip.
 - a. Products: Subject to compliance with requirements, provide one of the following:
 - 1) Dow Chemical Company (The); Saran 540 Vapor Retarder Film and Saran 560 Vapor Retarder Film.
6. Vinyl Jacket: White vinyl with a permeance of 1.3 perms when tested according to ASTM E 96, Procedure A, and complying with NFPA 90A and NFPA 90B.

2.8 FIELD-APPLIED FABRIC-REINFORCING MESH

- A. Woven Glass-Fiber Fabric for Pipe Insulation: Approximately 2 oz./sq. yd. with a thread count of 10 strands by 10 strands/sq. inch for covering pipe and pipe fittings.
 1. Products: Subject to compliance with requirements, provide one of the following:
 - a. Vimasco Corporation; Elastafab 894.
- B. Woven Glass-Fiber Fabric for Duct and Equipment Insulation: Approximately 6 oz./sq. yd. with a thread count of 5 strands by 5 strands/sq. inch for covering equipment.
 1. Products: Subject to compliance with requirements, provide one of the following:
 - a. Childers Products, Division of ITW; Chil-Glas No. 5.
- C. Woven Polyester Fabric: Approximately 1 oz./sq. yd. with a thread count of 10 strands by 10 strands/sq. inch, in a Leno weave, for duct, equipment, and pipe.
 1. Products: Subject to compliance with requirements, provide one of the following:
 - a. Foster Products Corporation, H. B. Fuller Company; Mast-A-Fab.
 - b. Vimasco Corporation; Elastafab 894.

2.9 FIELD-APPLIED CLOTHS

- A. Woven Glass-Fiber Fabric: Comply with MIL-C-20079H, Type I, plain weave, and presized a minimum of 8 oz./sq. yd..
 1. Products: Subject to compliance with requirements, provide one of the following:
 - a. Alpha Associates, Inc.; Alpha-Maritex 84215 and 84217/9485RW, Luben 59.

2.10 FIELD-APPLIED JACKETS

- A. Field-applied jackets shall comply with ASTM C 921, Type I, unless otherwise indicated.
- B. FSK Jacket: Aluminum-foil-face, fiberglass-reinforced scrim with kraft-paper backing.
- C. PVC Jacket: High-impact-resistant, UV-resistant PVC complying with ASTM D 1784, Class 16354-C; thickness as scheduled; roll stock ready for shop or field cutting and forming. Thickness is indicated in field-applied jacket schedules.
 - 1. Products: Subject to compliance with requirements, provide one of the following:
 - a. Johns Manville; Zeston.
 - b. P.I.C. Plastics, Inc.; FG Series.
 - c. Proto PVC Corporation; LoSmoke.
 - d. Speedline Corporation; SmokeSafe.
 - 2. Adhesive: As recommended by jacket material manufacturer.
 - 3. Color: White.
 - 4. Factory-fabricated fitting covers to match jacket if available; otherwise, field fabricate.
 - a. Shapes: 45- and 90-degree, short- and long-radius elbows, tees, valves, flanges, unions, reducers, end caps, soil-pipe hubs, traps, mechanical joints, and P-trap and supply covers for lavatories.
 - 5. Factory-fabricated tank heads and tank side panels.
- D. PVDC Jacket for Indoor Applications: 4-mil-thick, white PVDC biaxially oriented barrier film with a permeance at 0.02 perms when tested according to ASTM E 96 and with a flame-spread index of 5 and a smoke-developed index of 20 when tested according to ASTM E 84.
 - 1. Products: Subject to compliance with requirements, provide the following provide one of the following available products that may be incorporated into the Work include, but are not limited to, the following:
 - a. Dow Chemical Company (The), Saran 540 Vapor Retarder Film.
- E. PVDC Jacket for Outdoor Applications: 6-mil-thick, white PVDC biaxially oriented barrier film with a permeance at 0.01 perms when tested according to ASTM E 96 and with a flame-spread index of 5 and a smoke-developed index of 25 when tested according to ASTM E 84.
 - 1. Products: Subject to compliance with requirements, provide one of the following:
 - a. Dow Chemical Company (The), Saran 560 Vapor Retarder Film.

- F. PVDC-SSL Jacket: PVDC jacket with a self-sealing, pressure-sensitive, acrylic-based adhesive covered by a removable protective strip.
 - 1. Products: Subject to compliance with requirements, provide one of the following:
 - a. Dow Chemical Company (The); Saran 540 Vapor Retarder Film and Saran 560 Vapor Retarder Film.

2.11 TAPES

- A. ASJ Tape: White vapor-retarder tape matching factory-applied jacket with acrylic adhesive, complying with ASTM C 1136.
 - 1. Products: Subject to compliance with requirements, provide one of the following:
 - a. Avery Dennison Corporation, Specialty Tapes Division; Fasson 0835.
 - b. Compac Corp.; 104 and 105.
 - c. Ideal Tape Co., Inc., an American Biltrite Company; 428 AWF ASJ.
 - d. Venture Tape; 1540 CW Plus, 1542 CW Plus, and 1542 CW Plus/SQ.
 - 2. Width: 3 inches.
 - 3. Thickness: 11.5 mils.
 - 4. Adhesion: 90 ounces force/inch in width.
 - 5. Elongation: 2 percent.
 - 6. Tensile Strength: 40 lbf/inch in width.
 - 7. ASJ Tape Disks and Squares: Precut disks or squares of ASJ tape.
- B. PVC Tape: White vapor-retarder tape matching field-applied PVC jacket with acrylic adhesive. Suitable for indoor and outdoor applications.
 - 1. Products: Subject to compliance with requirements, provide one of the following:
 - a. Avery Dennison Corporation, Specialty Tapes Division; Fasson 0555.
 - b. Compac Corp.; 130.
 - c. Ideal Tape Co., Inc., an American Biltrite Company; 370 White PVC tape.
 - d. Venture Tape; 1506 CW NS.
 - 2. Width: 2 inches.

3. Thickness: 6 mils.
 4. Adhesion: 64 ounces force/inch in width.
 5. Elongation: 500 percent.
 6. Tensile Strength: 18 lbf/inch in width.
- C. Aluminum-Foil Tape: Vapor-retarder tape with acrylic adhesive.
1. Products: Subject to compliance with requirements, provide one of the following:
 - a. Avery Dennison Corporation, Specialty Tapes Division; Fasson 0800.
 - b. Compac Corp.; 120.
 - c. Ideal Tape Co., Inc., an American Biltrite Company; 488 AWF.
 - d. Venture Tape; 3520 CW.
 2. Width: 2 inches.
 3. Thickness: 3.7 mils.
 4. Adhesion: 100 ounces force/inch in width.
 5. Elongation: 5 percent.
 6. Tensile Strength: 34 lbf/inch in width.
- D. PVDC Tape for Indoor Applications: White vapor-retarder PVDC tape with acrylic adhesive.
1. Products: Subject to compliance with requirements, provide one of the following:
 - a. Dow Chemical Company (The); Saran 540 Vapor Retarder Tape.
 2. Width: 3 inches.
 3. Film Thickness: 4 mils.
 4. Adhesive Thickness: 1.5 mils.
 5. Elongation at Break: 145 percent.
 6. Tensile Strength: 55 lbf/inch in width.
- E. PVDC Tape for Outdoor Applications: White vapor-retarder PVDC tape with acrylic adhesive.
1. Products: Subject to compliance with requirements, provide one of the following:
 - a. Dow Chemical Company (The); Saran 560 Vapor Retarder Tape.

2. Width: 3 inches.
3. Film Thickness: 6 mils.
4. Adhesive Thickness: 1.5 mils.
5. Elongation at Break: 145 percent.
6. Tensile Strength: 55 lbf/inch in width.

2.12 SECUREMENTS

A. Bands:

1. Products: Subject to compliance with requirements, provide one of the following:
 - a. Childers Products; Bands.
 - b. PABCO Metals Corporation; Bands.
 - c. RPR Products, Inc.; Bands.
2. Stainless Steel: ASTM A 167 or ASTM A 240/A 240M, Type 304; 0.015 inch thick, 1/2 inch, 3/4 inch wide with wing seal.
3. Aluminum: ASTM B 209 (ASTM B 209M), Alloy 3003, 3005, 3105, or 5005; Temper H-14, 0.020 inch thick, 1/2 inch, 3/4 inch wide with wing seal.
4. Springs: Twin spring set constructed of stainless steel with ends flat and slotted to accept metal bands. Spring size determined by manufacturer for application.

B. Staples: Outward-clinching insulation staples, nominal 3/4-inch wide, stainless steel or Monel.

C. Wire: 0.080-inch nickel-copper alloy, 0.062-inch soft-annealed, stainless steel, 0.062-inch soft-annealed, galvanized steel.

1. Manufacturers: Subject to compliance with requirements, provide products by one of the following:
 - a. C & F Wire.
 - b. Childers Products.
 - c. PABCO Metals Corporation.
 - d. RPR Products, Inc.

2.13 CORNER ANGLES

- A. PVC Corner Angles: 30 mils thick, minimum 1 by 1 inch, PVC according to ASTM D 1784, Class 16354-C. White or color-coded to match adjacent surface.
- B. Aluminum Corner Angles: 0.040 inch thick, minimum 1 by 1 inch, aluminum according to ASTM B 209 (ASTM B 209M), Alloy 3003, 3005, 3105 or 5005; Temper H-14.
- C. Stainless-Steel Corner Angles: 0.024 inch thick, minimum 1 by 1 inch, stainless steel according to ASTM A 167 or ASTM A 240/A 240M, Type 304.

PART 3 - EXECUTION

3.1 EXAMINATION

- A. Examine substrates and conditions for compliance with requirements for installation and other conditions affecting performance of insulation application.
 - 1. Verify that systems and equipment to be insulated have been tested and are free of defects.
 - 2. Verify that surfaces to be insulated are clean and dry.
 - 3. Proceed with installation only after unsatisfactory conditions have been corrected.

3.2 PREPARATION

- A. Surface Preparation: Clean and dry surfaces to receive insulation. Remove materials that will adversely affect insulation application.
- B. Surface Preparation: Clean and prepare surfaces to be insulated. Before insulating, apply a corrosion coating to insulated surfaces as follows:
 - 1. Stainless Steel: Coat 300 series stainless steel with an epoxy primer 5 mils thick and an epoxy finish 5 mils thick if operating in a temperature range between 140 and 300 deg F. Consult coating manufacturer for appropriate coating materials and application methods for operating temperature range.
 - 2. Carbon Steel: Coat carbon steel operating at a service temperature between 32 and 300 deg F with an epoxy coating. Consult coating manufacturer for appropriate coating materials and application methods for operating temperature range.
- C. Coordinate insulation installation with the trade installing heat tracing. Comply with requirements for heat tracing that apply to insulation.

3.3 GENERAL INSTALLATION REQUIREMENTS

- A. Install insulation materials, accessories, and finishes with smooth, straight, and even surfaces; free of voids throughout the length of equipment, ducts and fittings, and piping including fittings, valves, and specialties.
- B. Install insulation materials, forms, vapor barriers or retarders, jackets, and thicknesses required for each item of equipment, duct system, and pipe system as specified in insulation system schedules.
- C. Install accessories compatible with insulation materials and suitable for the service. Install accessories that do not corrode, soften, or otherwise attack insulation or jacket in either wet or dry state.
- D. Install insulation with longitudinal seams at top and bottom of horizontal runs.
- E. Install multiple layers of insulation with longitudinal and end seams staggered.
- F. Do not weld brackets, clips, or other attachment devices to piping, fittings, and specialties.
- G. Keep insulation materials dry during application and finishing.
- H. Install insulation with tight longitudinal seams and end joints. Bond seams and joints with adhesive recommended by insulation material manufacturer.
- I. Install insulation with least number of joints practical.
- J. Where vapor barrier is indicated, seal joints, seams, and penetrations in insulation at hangers, supports, anchors, and other projections with vapor-barrier mastic.
 - 1. Install insulation continuously through hangers and around anchor attachments.
 - 2. For insulation application where vapor barriers are indicated, extend insulation on anchor legs from point of attachment to supported item to point of attachment to structure. Taper and seal ends at attachment to structure with vapor-barrier mastic.
 - 3. Install insert materials and install insulation to tightly join the insert. Seal insulation to insulation inserts with adhesive or sealing compound recommended by insulation material manufacturer.
 - 4. Cover inserts with jacket material matching adjacent pipe insulation. Install shields over jacket, arranged to protect jacket from tear or puncture by hanger, support, and shield.
- K. Apply adhesives, mastics, and sealants at manufacturer's recommended coverage rate and wet and dry film thicknesses.
- L. Install insulation with factory-applied jackets as follows:
 - 1. Draw jacket tight and smooth.

2. Cover circumferential joints with 3-inch-wide strips, of same material as insulation jacket. Secure strips with adhesive and outward clinching staples along both edges of strip, spaced 4 inches o.c.
 3. Overlap jacket longitudinal seams at least 1-1/2 inches. Install insulation with longitudinal seams at bottom of pipe. Clean and dry surface to receive self-sealing lap. Staple laps with outward clinching staples along edge at 2 inches, 4 inches o.c.
 - a. For below ambient services, apply vapor-barrier mastic over staples.
 4. Cover joints and seams with tape as recommended by insulation material manufacturer to maintain vapor seal.
 5. Where vapor barriers are indicated, apply vapor-barrier mastic on seams and joints and at ends adjacent to duct and pipe flanges and fittings.
- M. Cut insulation in a manner to avoid compressing insulation more than 75 percent of its nominal thickness.
- N. Finish installation with systems at operating conditions. Repair joint separations and cracking due to thermal movement.
- O. Repair damaged insulation facings by applying same facing material over damaged areas. Extend patches at least 4 inches beyond damaged areas. Adhere, staple, and seal patches similar to butt joints.
- P. For above ambient services, do not install insulation to the following:
1. Vibration-control devices.
 2. Testing agency labels and stamps.
 3. Nameplates and data plates.
 4. Handholes.
 5. Cleanouts.
- ### 3.4 PENETRATIONS
- A. Insulation Installation at Roof Penetrations: Install insulation continuously through roof penetrations.
1. Seal penetrations with flashing sealant.
 2. For applications requiring only indoor insulation, terminate insulation above roof surface and seal with joint sealant. For applications requiring indoor and outdoor insulation, install insulation for outdoor applications tightly joined to indoor insulation ends. Seal joint with joint sealant.

3. Extend jacket of outdoor insulation outside roof flashing at least 2 inches below top of roof flashing.
 4. Seal jacket to roof flashing with flashing sealant.
- B. Insulation Installation at Underground Exterior Wall Penetrations: Terminate insulation flush with sleeve seal. Seal terminations with flashing sealant.
- C. Insulation Installation at Aboveground Exterior Wall Penetrations: Install insulation continuously through wall penetrations.
1. Seal penetrations with flashing sealant.
 2. For applications requiring only indoor insulation, terminate insulation inside wall surface and seal with joint sealant. For applications requiring indoor and outdoor insulation, install insulation for outdoor applications tightly joined to indoor insulation ends. Seal joint with joint sealant.
 3. Extend jacket of outdoor insulation outside wall flashing and overlap wall flashing at least 2 inches.
 4. Seal jacket to wall flashing with flashing sealant.
- D. Insulation Installation at Interior Wall and Partition Penetrations (That Are Not Fire Rated): Install insulation continuously through walls and partitions.
- E. Insulation Installation at Fire-Rated Wall and Partition Penetrations: Install insulation continuously through penetrations of fire-rated walls and partitions. Terminate insulation at fire damper sleeves for fire-rated wall and partition penetrations. Externally insulate damper sleeves to match adjacent insulation and overlap duct insulation at least 2 inches.
1. Comply with requirements in Division 07 Section "Penetration Firestopping" firestopping and fire-resistive joint sealers.
- F. Insulation Installation at Floor Penetrations:
1. Duct: Install insulation continuously through floor penetrations that are not fire rated. For penetrations through fire-rated assemblies, terminate insulation at fire damper sleeves and externally insulate damper sleeve beyond floor to match adjacent duct insulation. Overlap damper sleeve and duct insulation at least 2 inches.
 2. Pipe: Install insulation continuously through floor penetrations.
 3. Seal penetrations through fire-rated assemblies. Comply with requirements in Division 07 Section "Penetration Firestopping."

3.5 EQUIPMENT, TANK, AND VESSEL INSULATION INSTALLATION

- A. Mineral Fiber, Pipe and Tank Insulation Installation for Tanks and Vessels: Secure insulation with adhesive and anchor pins and speed washers.
1. Apply adhesives according to manufacturer's recommended coverage rates per unit area, for 100 percent coverage of tank and vessel surfaces.
 2. Groove and score insulation materials to fit as closely as possible to equipment, including contours. Bevel insulation edges for cylindrical surfaces for tight joints. Stagger end joints.
 3. Protect exposed corners with secured corner angles.
 4. Install adhesively attached or self-sticking insulation hangers and speed washers on sides of tanks and vessels as follows:
 - a. Do not weld anchor pins to ASME-labeled pressure vessels.
 - b. Select insulation hangers and adhesive that are compatible with service temperature and with substrate.
 - c. On tanks and vessels, maximum anchor-pin spacing is 3 inches from insulation end joints, and 16 inches o.c. in both directions.
 - d. Do not overcompress insulation during installation.
 - e. Cut and miter insulation segments to fit curved sides and domed heads of tanks and vessels.
 - f. Impale insulation over anchor pins and attach speed washers.
 - g. Cut excess portion of pins extending beyond speed washers or bend parallel with insulation surface. Cover exposed pins and washers with tape matching insulation facing.
 5. Secure each layer of insulation with stainless-steel or aluminum bands. Select band material compatible with insulation materials.
 6. Where insulation hangers on equipment and vessels are not permitted or practical and where insulation support rings are not provided, install a girdle network for securing insulation. Stretch prestressed aircraft cable around the diameter of vessel and make taut with clamps, turnbuckles, or breather springs. Place one circumferential girdle around equipment approximately 6 inches from each end. Install wire or cable between two circumferential girdles 12 inches o.c. Install a wire ring around each end and around outer periphery of center openings, and stretch prestressed aircraft cable radially from the wire ring to nearest circumferential girdle. Install additional circumferential girdles along the body of equipment or tank at a minimum spacing of 48 inches o.c. Use this network for securing insulation with tie wire or bands.

7. Stagger joints between insulation layers at least 3 inches.
 8. Install insulation in removable segments on equipment access doors, manholes, handholes, and other elements that require frequent removal for service and inspection.
 9. Bevel and seal insulation ends around manholes, handholes, ASME stamps, and nameplates.
 10. For equipment with surface temperatures below ambient, apply mastic to open ends, joints, seams, breaks, and punctures in insulation.
- B. Flexible Elastomeric Thermal Insulation Installation for Tanks and Vessels: Install insulation over entire surface of tanks and vessels.
1. Apply 100 percent coverage of adhesive to surface with manufacturer's recommended adhesive.
 2. Seal longitudinal seams and end joints.
- C. Insulation Installation on Pumps:
1. Fabricate metal boxes lined with insulation. Fit boxes around pumps and coincide box joints with splits in pump casings. Fabricate joints with outward bolted flanges. Bolt flanges on 6-inch centers, starting at corners. Install 3/8-inch diameter fasteners with wing nuts. Alternatively, secure the box sections together using a latching mechanism.
 2. Fabricate boxes from galvanized steel, at least 0.050 inch thick.
 3. For below ambient services, install a vapor barrier at seams, joints, and penetrations. Seal between flanges with replaceable gasket material to form a vapor barrier.

3.6 GENERAL PIPE INSULATION INSTALLATION

- A. Requirements in this article generally apply to all insulation materials except where more specific requirements are specified in various pipe insulation material installation articles.
- B. Insulation Installation on Fittings, Valves, Strainers, Flanges, and Unions:
1. Install insulation over fittings, valves, strainers, flanges, unions, and other specialties with continuous thermal and vapor-retarder integrity, unless otherwise indicated.
 2. Insulate pipe elbows using preformed fitting insulation or mitered fittings made from same material and density as adjacent pipe insulation. Each piece shall be butted tightly against adjoining piece and bonded with adhesive. Fill joints, seams, voids, and irregular surfaces with insulating cement finished to a smooth, hard, and uniform contour that is uniform with adjoining pipe insulation.

3. Insulate tee fittings with preformed fitting insulation or sectional pipe insulation of same material and thickness as used for adjacent pipe. Cut sectional pipe insulation to fit. Butt each section closely to the next and hold in place with tie wire. Bond pieces with adhesive.
 4. Insulate valves using preformed fitting insulation or sectional pipe insulation of same material, density, and thickness as used for adjacent pipe. Overlap adjoining pipe insulation by not less than two times the thickness of pipe insulation, or one pipe diameter, whichever is thicker. For valves, insulate up to and including the bonnets, valve stuffing-box studs, bolts, and nuts. Fill joints, seams, and irregular surfaces with insulating cement.
 5. Insulate strainers using preformed fitting insulation or sectional pipe insulation of same material, density, and thickness as used for adjacent pipe. Overlap adjoining pipe insulation by not less than two times the thickness of pipe insulation, or one pipe diameter, whichever is thicker. Fill joints, seams, and irregular surfaces with insulating cement. Insulate strainers so strainer basket flange or plug can be easily removed and replaced without damaging the insulation and jacket. Provide a removable reusable insulation cover. For below ambient services, provide a design that maintains vapor barrier.
 6. Insulate flanges and unions using a section of oversized preformed pipe insulation. Overlap adjoining pipe insulation by not less than two times the thickness of pipe insulation, or one pipe diameter, whichever is thicker.
 7. Cover segmented insulated surfaces with a layer of finishing cement and coat with a mastic. Install vapor-barrier mastic for below ambient services and a breather mastic for above ambient services. Reinforce the mastic with fabric-reinforcing mesh. Trowel the mastic to a smooth and well-shaped contour.
 8. For services not specified to receive a field-applied jacket except for flexible elastomeric and polyolefin, install fitted PVC cover over elbows, tees, strainers, valves, flanges, and unions. Terminate ends with PVC end caps. Tape PVC covers to adjoining insulation facing using PVC tape.
 9. Stencil or label the outside insulation jacket of each union with the word "UNION." Match size and color of pipe labels.
- C. Insulate instrument connections for thermometers, pressure gages, pressure temperature taps, test connections, flow meters, sensors, switches, and transmitters on insulated pipes, vessels, and equipment. Shape insulation at these connections by tapering it to and around the connection with insulating cement and finish with finishing cement, mastic, and flashing sealant.
- D. Install removable insulation covers at locations indicated. Installation shall conform to the following:
1. Make removable flange and union insulation from sectional pipe insulation of same thickness as that on adjoining pipe. Install same insulation jacket as adjoining pipe insulation.
 2. When flange and union covers are made from sectional pipe insulation, extend insulation from flanges or union long at least two times the insulation thickness over adjacent pipe

insulation on each side of flange or union. Secure flange cover in place with stainless-steel or aluminum bands. Select band material compatible with insulation and jacket.

3. Construct removable valve insulation covers in same manner as for flanges except divide the two-part section on the vertical center line of valve body.
4. When covers are made from block insulation, make two halves, each consisting of mitered blocks wired to stainless-steel fabric. Secure this wire frame, with its attached insulation, to flanges with tie wire. Extend insulation at least 2 inches over adjacent pipe insulation on each side of valve. Fill space between flange or union cover and pipe insulation with insulating cement. Finish cover assembly with insulating cement applied in two coats. After first coat is dry, apply and trowel second coat to a smooth finish.
5. Unless a PVC jacket is indicated in field-applied jacket schedules, finish exposed surfaces with a metal jacket.

3.7 CELLULAR-GLASS INSULATION INSTALLATION

A. Insulation Installation on Straight Pipes and Tubes:

1. Secure each layer of insulation to pipe with wire or bands and tighten bands without deforming insulation materials.
2. Where vapor barriers are indicated, seal longitudinal seams, end joints, and protrusions with vapor-barrier mastic and joint sealant.
3. For insulation with factory-applied jackets on above ambient services, secure laps with outward clinched staples at 6 inches o.c.
4. For insulation with factory-applied jackets on below ambient services, do not staple longitudinal tabs but secure tabs with additional adhesive as recommended by insulation material manufacturer and seal with vapor-barrier mastic and flashing sealant.

B. Insulation Installation on Pipe Flanges:

1. Install preformed pipe insulation to outer diameter of pipe flange.
2. Make width of insulation section same as overall width of flange and bolts, plus twice the thickness of pipe insulation.
3. Fill voids between inner circumference of flange insulation and outer circumference of adjacent straight pipe segments with cut sections of cellular-glass block insulation of same thickness as pipe insulation.
4. Install jacket material with manufacturer's recommended adhesive, overlap seams at least 1 inch, and seal joints with flashing sealant.

C. Insulation Installation on Pipe Fittings and Elbows:

1. Install preformed sections of same material as straight segments of pipe insulation when available. Secure according to manufacturer's written instructions.
2. When preformed sections of insulation are not available, install mitered sections of cellular-glass insulation. Secure insulation materials with wire or bands.

D. Insulation Installation on Valves and Pipe Specialties:

1. Install preformed sections of cellular-glass insulation to valve body.
2. Arrange insulation to permit access to packing and to allow valve operation without disturbing insulation.
3. Install insulation to flanges as specified for flange insulation application.

3.8 FLEXIBLE ELASTOMERIC INSULATION INSTALLATION

A. Seal longitudinal seams and end joints with manufacturer's recommended adhesive to eliminate openings in insulation that allow passage of air to surface being insulated.

B. Insulation Installation on Pipe Flanges:

1. Install pipe insulation to outer diameter of pipe flange.
2. Make width of insulation section same as overall width of flange and bolts, plus twice the thickness of pipe insulation.
3. Fill voids between inner circumference of flange insulation and outer circumference of adjacent straight pipe segments with cut sections of sheet insulation of same thickness as pipe insulation.
4. Secure insulation to flanges and seal seams with manufacturer's recommended adhesive to eliminate openings in insulation that allow passage of air to surface being insulated.

C. Insulation Installation on Pipe Fittings and Elbows:

1. Install mitered sections of pipe insulation.
2. Secure insulation materials and seal seams with manufacturer's recommended adhesive to eliminate openings in insulation that allow passage of air to surface being insulated.

D. Insulation Installation on Valves and Pipe Specialties:

1. Install preformed valve covers manufactured of same material as pipe insulation when available.
2. When preformed valve covers are not available, install cut sections of pipe and sheet insulation to valve body. Arrange insulation to permit access to packing and to allow valve operation without disturbing insulation.

3. Install insulation to flanges as specified for flange insulation application.
4. Secure insulation to valves and specialties and seal seams with manufacturer's recommended adhesive to eliminate openings in insulation that allow passage of air to surface being insulated.

3.9 MINERAL-FIBER INSULATION INSTALLATION

A. Insulation Installation on Straight Pipes and Tubes:

1. Secure each layer of preformed pipe insulation to pipe with wire or bands and tighten bands without deforming insulation materials.
2. Where vapor barriers are indicated, seal longitudinal seams, end joints, and protrusions with vapor-barrier mastic and joint sealant.
3. For insulation with factory-applied jackets on above ambient surfaces, secure laps with outward clinched staples at 6 inches o.c.
4. For insulation with factory-applied jackets on below ambient surfaces, do not staple longitudinal tabs but secure tabs with additional adhesive as recommended by insulation material manufacturer and seal with vapor-barrier mastic and flashing sealant.

B. Insulation Installation on Pipe Flanges:

1. Install preformed pipe insulation to outer diameter of pipe flange.
2. Make width of insulation section same as overall width of flange and bolts, plus twice the thickness of pipe insulation.
3. Fill voids between inner circumference of flange insulation and outer circumference of adjacent straight pipe segments with mineral-fiber blanket insulation.
4. Install jacket material with manufacturer's recommended adhesive, overlap seams at least 1 inch, and seal joints with flashing sealant.

C. Insulation Installation on Pipe Fittings and Elbows:

1. Install preformed sections of same material as straight segments of pipe insulation when available.
2. When preformed insulation elbows and fittings are not available, install mitered sections of pipe insulation, to a thickness equal to adjoining pipe insulation. Secure insulation materials with wire or bands.

D. Insulation Installation on Valves and Pipe Specialties:

1. Install preformed sections of same material as straight segments of pipe insulation when available.

2. When preformed sections are not available, install mitered sections of pipe insulation to valve body.
 3. Arrange insulation to permit access to packing and to allow valve operation without disturbing insulation.
 4. Install insulation to flanges as specified for flange insulation application.
- E. Blanket Insulation Installation on Ducts and Plenums: Secure with adhesive and insulation pins.
1. Apply adhesives according to manufacturer's recommended coverage rates per unit area, for 100 percent coverage of duct and plenum surfaces.
 2. Apply adhesive to entire circumference of ducts and to all surfaces of fittings and transitions.
 3. Install either capacitor-discharge-weld pins and speed washers or cupped-head, capacitor-discharge-weld pins on sides and bottom of horizontal ducts and sides of vertical ducts as follows:
 - a. On duct sides with dimensions 18 inches and smaller, place pins along longitudinal centerline of duct. Space 3 inches maximum from insulation end joints, and 16 inches o.c.
 - b. On duct sides with dimensions larger than 18 inches, place pins 16 inches o.c. each way, and 3 inches maximum from insulation joints. Install additional pins to hold insulation tightly against surface at cross bracing.
 - c. Pins may be omitted from top surface of horizontal, rectangular ducts and plenums.
 - d. Do not overcompress insulation during installation.
 - e. Impale insulation over pins and attach speed washers.
 - f. Cut excess portion of pins extending beyond speed washers or bend parallel with insulation surface. Cover exposed pins and washers with tape matching insulation facing.
 4. For ducts and plenums with surface temperatures below ambient, install a continuous unbroken vapor barrier. Create a facing lap for longitudinal seams and end joints with insulation by removing 2 inches from 1 edge and 1 end of insulation segment. Secure laps to adjacent insulation section with 1/2-inch outward-clinching staples, 1 inch o.c. Install vapor barrier consisting of factory- or field-applied jacket, adhesive, vapor-barrier mastic, and sealant at joints, seams, and protrusions.
 - a. Repair punctures, tears, and penetrations with tape or mastic to maintain vapor-barrier seal.
 - b. Install vapor stops for ductwork and plenums operating below 50 deg F at 18-foot intervals. Vapor stops shall consist of vapor-barrier mastic applied in a Z-shaped

pattern over insulation face, along butt end of insulation, and over the surface. Cover insulation face and surface to be insulated a width equal to 2 times the insulation thickness but not less than 3 inches.

5. Overlap unfaced blankets a minimum of 2 inches on longitudinal seams and end joints. At end joints, secure with steel bands spaced a maximum of 18 inches o.c.
 6. Install insulation on rectangular duct elbows and transitions with a full insulation section for each surface. Install insulation on round and flat-oval duct elbows with individually mitered gores cut to fit the elbow.
 7. Insulate duct stiffeners, hangers, and flanges that protrude beyond insulation surface with 6-inch-wide strips of same material used to insulate duct. Secure on alternating sides of stiffener, hanger, and flange with pins spaced 6 inches o.c.
- F. Board Insulation Installation on Ducts and Plenums: Secure with adhesive and insulation pins.
1. Apply adhesives according to manufacturer's recommended coverage rates per unit area, for 100 percent coverage of duct and plenum surfaces.
 2. Apply adhesive to entire circumference of ducts and to all surfaces of fittings and transitions.
 3. Install either capacitor-discharge-weld pins and speed washers or cupped-head, capacitor-discharge-weld pins on sides and bottom of horizontal ducts and sides of vertical ducts as follows:
 - a. On duct sides with dimensions 18 inches and smaller, place pins along longitudinal centerline of duct. Space 3 inches maximum from insulation end joints, and 16 inches o.c.
 - b. On duct sides with dimensions larger than 18 inches, space pins 16 inches o.c. each way, and 3 inches maximum from insulation joints. Install additional pins to hold insulation tightly against surface at cross bracing.
 - c. Pins may be omitted from top surface of horizontal, rectangular ducts and plenums.
 - d. Do not overcompress insulation during installation.
 - e. Cut excess portion of pins extending beyond speed washers or bend parallel with insulation surface. Cover exposed pins and washers with tape matching insulation facing.
 4. For ducts and plenums with surface temperatures below ambient, install a continuous unbroken vapor barrier. Create a facing lap for longitudinal seams and end joints with insulation by removing 2 inches from 1 edge and 1 end of insulation segment. Secure laps to adjacent insulation section with 1/2-inch outward-clinching staples, 1 inch o.c. Install vapor barrier consisting of factory- or field-applied jacket, adhesive, vapor-barrier mastic, and sealant at joints, seams, and protrusions.

- a. Repair punctures, tears, and penetrations with tape or mastic to maintain vapor-barrier seal.
 - b. Install vapor stops for ductwork and plenums operating below 50 deg F at 18-foot intervals. Vapor stops shall consist of vapor-barrier mastic applied in a Z-shaped pattern over insulation face, along butt end of insulation, and over the surface. Cover insulation face and surface to be insulated a width equal to 2 times the insulation thickness but not less than 3 inches.
5. Install insulation on rectangular duct elbows and transitions with a full insulation section for each surface. Groove and score insulation to fit as closely as possible to outside and inside radius of elbows. Install insulation on round and flat-oval duct elbows with individually mitered gores cut to fit the elbow.
 6. Insulate duct stiffeners, hangers, and flanges that protrude beyond insulation surface with 6-inch-wide strips of same material used to insulate duct. Secure on alternating sides of stiffener, hanger, and flange with pins spaced 6 inches o.c.

3.10 FIELD-APPLIED JACKET INSTALLATION

- A. Where glass-cloth jackets are indicated, install directly over bare insulation or insulation with factory-applied jackets.
 1. Draw jacket smooth and tight to surface with 2-inch overlap at seams and joints.
 2. Embed glass cloth between two 0.062-inch- thick coats of lagging adhesive.
 3. Completely encapsulate insulation with coating, leaving no exposed insulation.
- B. Where PVC jackets are indicated, install with 1-inch overlap at longitudinal seams and end joints; for horizontal applications, install with longitudinal seams along top and bottom of tanks and vessels. Seal with manufacturer's recommended adhesive.
 1. Apply two continuous beads of adhesive to seams and joints, one bead under lap and the finish bead along seam and joint edge.
- C. Where metal jackets are indicated, install with 2-inch overlap at longitudinal seams and end joints. Overlap longitudinal seams arranged to shed water. Seal end joints with weatherproof sealant recommended by insulation manufacturer. Secure jacket with stainless-steel bands 12 inches o.c. and at end joints.
- D. Where PVDC jackets are indicated, install as follows:
 1. Apply three separate wraps of filament tape per insulation section to secure pipe insulation to pipe prior to installation of PVDC jacket.
 2. Wrap factory-presize jackets around individual pipe insulation sections with one end overlapping the previously installed sheet. Install presize jacket with an approximate overlap at butt joint of 2 inches over the previous section. Adhere lap seal using adhesive

or SSL, and then apply 1-1/4 circumferences of appropriate PVDC tape around overlapped butt joint.

3. Continuous jacket can be spiral wrapped around a length of pipe insulation. Apply adhesive or PVDC tape at overlapped spiral edge. When electing to use adhesives, refer to manufacturer's written instructions for application of adhesives along this spiral edge to maintain a permanent bond.
4. Jacket can be wrapped in cigarette fashion along length of roll for insulation systems with an outer circumference of 33-1/2 inches or less. The 33-1/2-inch- circumference limit allows for 2-inch- overlap seal. Using the length of roll allows for longer sections of jacket to be installed at one time. Use adhesive on the lap seal. Visually inspect lap seal for "fishmouthing," and use PVDC tape along lap seal to secure joint.
5. Repair holes or tears in PVDC jacket by placing PVDC tape over the hole or tear and wrapping a minimum of 1-1/4 circumferences to avoid damage to tape edges.

3.11 FIRE-RATED INSULATION SYSTEM INSTALLATION

- A. Where fire-rated insulation system is indicated, secure system to ducts and duct hangers and supports to maintain a continuous fire rating.
- B. Insulate duct access panels and doors to achieve same fire rating as duct.
- C. Install firestopping at penetrations through fire-rated assemblies. Fire-stop systems are specified in Division 07 Section "Penetration Firestopping."

3.12 FINISHES

- A. Duct, Equipment, and Pipe Insulation with ASJ, Glass-Cloth, or Other Paintable Jacket Material: Paint jacket with paint system identified below and as specified in Division 09 painting Sections.
 1. Flat Acrylic Finish: Two finish coats over a primer that is compatible with jacket material and finish coat paint. Add fungicidal agent to render fabric mildew proof.
 - a. Finish Coat Material: Interior, flat, latex-emulsion size.
- B. Flexible Elastomeric Thermal Insulation: After adhesive has fully cured, apply two coats of insulation manufacturer's recommended protective coating.
- C. Color: Final color as selected by Architect. Vary first and second coats to allow visual inspection of the completed Work.
- D. Do not field paint aluminum or stainless-steel jackets.

3.13 FIELD QUALITY CONTROL

- A. Testing Agency: Engage a qualified testing agency to perform tests and inspections.

- B. Perform tests and inspections.
- C. Tests and Inspections:
 - 1. Inspect ductwork, randomly selected by Architect, by removing field-applied jacket and insulation in layers in reverse order of their installation. Extent of inspection shall be limited to one location(s) for each duct system defined in the "Duct Insulation Schedule, General" Article.
 - 2. Inspect field-insulated equipment, randomly selected by Architect, by removing field-applied jacket and insulation in layers in reverse order of their installation. Extent of inspection shall be limited to one location(s) for each type of equipment defined in the "Equipment Insulation Schedule" Article. For large equipment, remove only a portion adequate to determine compliance.
 - 3. Inspect pipe, fittings, strainers, and valves, randomly selected by Architect, by removing field-applied jacket and insulation in layers in reverse order of their installation. Extent of inspection shall be limited to three locations of straight pipe, three locations of threaded fittings, three locations of welded fittings, two locations of threaded strainers, two locations of welded strainers, three locations of threaded valves, and three locations of flanged valves for each pipe service defined in the "Piping Insulation Schedule, General" Article.
- D. All insulation applications will be considered defective Work if sample inspection reveals noncompliance with requirements.

3.14 BOILER BREECHING INSULATION SCHEDULE

- A. Round, exposed breeching and connector insulation shall be one of the following:
 - 1. High-Temperature Mineral-Fiber Blanket: 3 inches thick and 3-lb/cu. ft. nominal density.
 - 2. High-Temperature Mineral-Fiber Board: 3 inches thick and 6-lb/cu. ft. nominal density.
- B. Round, concealed breeching and connector insulation shall be one of the following:
 - 1. High-Temperature Mineral-Fiber Blanket: 3 inches thick and 3-lb/cu. ft. nominal density.
 - 2. High-Temperature Mineral-Fiber Board: 3 inches thick and 6-lb/cu. ft. nominal density.
- C. Rectangular, exposed breeching and connector insulation shall be one of the following:
 - 1. High-Temperature Mineral-Fiber Blanket: 3 inches thick and 3-lb/cu. ft. nominal density.
 - 2. High-Temperature Mineral-Fiber Board: 3 inches thick and 6-lb/cu. ft. nominal density.
- D. Rectangular, concealed breeching and connector insulation shall be one of the following:
 - 1. High-Temperature Mineral-Fiber Blanket: 3 inches thick and 3-lb/cu. ft. nominal density.
 - 2. High-Temperature Mineral-Fiber Board: 3 inches thick and 6-lb/cu. ft. nominal density.

3.15 DUCT INSULATION SCHEDULE, GENERAL

A. Plenums and Ducts Requiring Insulation:

1. Indoor, concealed supply and outdoor air.
2. Indoor, exposed supply and outdoor air.
3. Indoor, concealed return located in nonconditioned space.
4. Indoor, exposed return located in nonconditioned space.
5. Indoor, concealed, Type I, commercial, kitchen hood exhaust.
6. Indoor, exposed, Type I, commercial, kitchen hood exhaust.
7. Indoor, concealed oven and warewash exhaust.
8. Indoor, exposed oven and warewash exhaust.
9. Indoor, concealed exhaust between isolation damper and penetration of building exterior.
10. Indoor, exposed exhaust between isolation damper and penetration of building exterior.
11. Outdoor, concealed supply and return.
12. Outdoor, exposed supply and return.
13. Exhaust Ductwork Upstream of Heat Recovery Device.

B. Items Not Insulated:

1. Fibrous-glass ducts.
2. Metal ducts with duct liner of sufficient thickness to comply with energy code and ASHRAE/IESNA 90.1.
3. Factory-insulated flexible ducts.
4. Factory-insulated plenums and casings.
5. Flexible connectors.
6. Vibration-control devices.
7. Factory-insulated access panels and doors.

3.16 INDOOR DUCT AND PLENUM INSULATION SCHEDULE

A. Concealed, round and flat-oval, supply-air duct insulation shall be one of the following:

1. Mineral-Fiber Blanket: 2 inches thick and 1.5-lb/cu. ft. nominal density.
 2. Mineral-Fiber Board: 2 inches thick and 3-lb/cu. ft. nominal density.
- B. Concealed, round and flat-oval, return-air duct insulation shall be one of the following:
1. Mineral-Fiber Blanket: 2 inches thick and 1.5-lb/cu. ft. nominal density.
 2. Mineral-Fiber Board: 2 inches thick and 3-lb/cu. ft. nominal density.
- C. Concealed, round and flat-oval, outdoor-air duct insulation shall be one of the following:
1. Mineral-Fiber Blanket: 3 inches thick and 3-lb/cu. ft. nominal density.
 2. Mineral-Fiber Board: 3 inches thick and 6-lb/cu. ft. nominal density.
- D. Concealed, round and flat-oval, exhaust-air duct insulation shall be one of the following:
1. Mineral-Fiber Blanket: 2 inches thick and 1.5-lb/cu. ft. nominal density.
 2. Mineral-Fiber Board: 2 inches thick and 3-lb/cu. ft. nominal density.
- E. Concealed, rectangular, supply-air duct insulation shall be one of the following:
1. Mineral-Fiber Blanket: 2 inches thick and 1.5-lb/cu. ft. nominal density.
 2. Mineral-Fiber Board: 2 inches thick and 3-lb/cu. ft. nominal density.
- F. Concealed, rectangular, return-air duct insulation shall be one of the following:
1. Mineral-Fiber Blanket: 2 inches thick and 1.5-lb/cu. ft. nominal density.
 2. Mineral-Fiber Board: 2 inches thick and 3-lb/cu. ft. nominal density.
- G. Concealed, rectangular, outdoor-air duct insulation shall be one of the following:
1. Mineral-Fiber Blanket: 2 inches thick and 3-lb/cu. ft. nominal density.
 2. Mineral-Fiber Board: 2 inches thick and 6-lb/cu. ft. nominal density.
- H. Concealed, rectangular, exhaust-air duct insulation between isolation damper and penetration of building exterior shall be one of the following:
1. Mineral-Fiber Blanket: 1-1/2 inches thick and 1.5-lb/cu. ft. nominal density.
 2. Mineral-Fiber Board: 1-1/2 inches thick and 2-lb/cu. ft. nominal density.
- I. Concealed, Type I, Commercial, Kitchen Hood Exhaust Duct and Plenum Insulation: Fire-rated board; thickness as required to achieve 2-hour fire rating.
- J. Concealed, supply-air plenum insulation shall be one of the following:

1. Mineral-Fiber Board: 2 inches thick and 3-lb/cu. ft. nominal density.
- K. Concealed, return-air plenum insulation shall be one of the following:
1. Mineral-Fiber Blanket: 2 inches thick and 3-lb/cu. ft. nominal density.
 2. Mineral-Fiber Board: 2 inches thick and 3-lb/cu. ft. nominal density.
- L. Concealed, outdoor-air plenum insulation shall be one of the following:
1. Mineral-Fiber Blanket: 1-1/2 inches thick and 1.5-lb/cu. ft. nominal density.
 2. Mineral-Fiber Board: 1-1/2 inches thick and 3-lb/cu. ft. nominal density.
- M. Concealed, exhaust-air plenum insulation shall be one of the following:
1. Mineral-Fiber Blanket: 1-1/2 inches thick and 1.5-lb/cu. ft. nominal density.
 2. Mineral-Fiber Board: 1-1/2 inches thick and 3-lb/cu. ft. nominal density.
- N. Exposed, round and flat-oval, supply-air duct insulation shall be one of the following:
1. Mineral-Fiber Blanket: 1-1/2 inches thick and 1.5-lb/cu. ft. nominal density.
 2. Mineral-Fiber Board: 1-1/2 inches thick and 3-lb/cu. ft. nominal density.
- O. Exposed, round and flat-oval, return-air duct insulation shall be one of the following:
1. Mineral-Fiber Blanket: 1-1/2 inches thick and 1.5-lb/cu. ft. nominal density.
 2. Mineral-Fiber Board: 1-1/2 inches thick and 3-lb/cu. ft. nominal density.
- P. Exposed, round and flat-oval, outdoor-air duct insulation shall be one of the following:
1. Mineral-Fiber Blanket: 1-1/2 inches thick and 1.5-lb/cu. ft. nominal density.
 2. Mineral-Fiber Board: 1-1/2 inches thick and 3-lb/cu. ft. nominal density.
- Q. Exposed, round and flat-oval, exhaust-air duct insulation shall be one of the following:
1. Mineral-Fiber Blanket: 2 inches thick and 1.5-lb/cu. ft. nominal density.
 2. Mineral-Fiber Board: 1-1/2 inches thick and 3-lb/cu. ft. nominal density.
- R. Exposed, rectangular, supply-air duct insulation shall be one of the following:
1. Mineral-Fiber Blanket: 1-1/2 inches thick and 1.5-lb/cu. ft. nominal density.
 2. Mineral-Fiber Board: 1-1/2 inches thick and 3-lb/cu. ft. nominal density.
- S. Exposed, rectangular, return-air duct insulation shall be one of the following:

1. Mineral-Fiber Blanket: 2 inches thick and 3-lb/cu. ft. nominal density.
 2. Mineral-Fiber Board: 2 inches thick and 3-lb/cu. ft. nominal density.
- T. Exposed, rectangular, outdoor-air duct insulation shall be one of the following:
1. Mineral-Fiber Blanket: 1-1/2 inches thick and 1.5-lb/cu. ft. nominal density.
 2. Mineral-Fiber Board: 1-1/2 inches thick and 3-lb/cu. ft. nominal density.
- U. Exposed, rectangular, exhaust-air duct insulation shall be one of the following:
1. Mineral-Fiber Blanket: 1-1/2 inches thick and 1.5-lb/cu. ft. nominal density.
 2. Mineral-Fiber Board: 1-1/2 inches thick and 3-lb/cu. ft. nominal density.
- V. Exposed, Type I, Commercial, Kitchen Hood Exhaust Duct and Plenum Insulation: Fire-rated board; thickness as required to achieve 2-hour fire rating.
- W. Exposed, supply-air plenum insulation shall be one of the following:
1. Mineral-Fiber Board: 2 inches thick and 3-lb/cu. ft. nominal density.
- X. Exposed, return-air plenum insulation shall be one of the following:
1. Mineral-Fiber Blanket: 2 inches thick and 1.5-lb/cu. ft. nominal density.
 2. Mineral-Fiber Board: 2 inches thick and 3-lb/cu. ft. nominal density.
- Y. Exposed, outdoor-air plenum insulation shall be one of the following:
1. Mineral-Fiber Blanket: 2 inches thick and 1.5-lb/cu. ft. nominal density.
 2. Mineral-Fiber Board: 1-1/2 inches thick and 3-lb/cu. ft. nominal density.
- Z. Exposed, exhaust-air plenum insulation shall be one of the following:
1. Mineral-Fiber Blanket: 1-1/2 inches thick and 1.5-lb/cu. ft. nominal density.
 2. Mineral-Fiber Board: 1-1/2 inches thick and 3-lb/cu. ft. nominal density.
- 3.17 ABOVEGROUND, OUTDOOR DUCT AND PLENUM INSULATION SCHEDULE
- A. Insulation materials and thicknesses are identified below. All outdoor ductwork shall be constructed with polyfoam board to fill gaps between the duct flanges with an additional layer of foam insulation on top of the duct (as applicable) that is tapered to shed water. If more than one material is listed for a duct system, selection from materials listed is Contractor's option.
- B. Concealed, round and flat-oval, supply-air duct insulation shall be one of the following:

1. Mineral-Fiber Blanket: 2 inches thick and 3-lb/cu. ft. nominal density.
 2. Mineral-Fiber Board: 2 inches thick and 3-lb/cu. ft. nominal density.
- C. Concealed, round and flat-oval, return-air duct insulation shall be one of the following:
1. Mineral-Fiber Blanket: 2 inches thick and 1.5-lb/cu. ft. nominal density.
 2. Mineral-Fiber Board: 2 inches thick and 3-lb/cu. ft. nominal density.
- D. Concealed, round and flat-oval, outdoor-air duct insulation shall be one of the following:
1. Mineral-Fiber Blanket: 2 inches thick and 1.5-lb/cu. ft. nominal density.
 2. Mineral-Fiber Board: 2 inches thick and 3-lb/cu. ft. nominal density.
- E. Concealed, rectangular, supply-air duct insulation shall be one of the following:
1. Mineral-Fiber Blanket: 2 inches thick and 3-lb/cu. ft. nominal density.
 2. Mineral-Fiber Board: 2 inches thick and 3-lb/cu. ft. nominal density.
- F. Concealed, rectangular, return-air duct insulation shall be one of the following:
1. Mineral-Fiber Blanket: 2 inches thick and 1.5-lb/cu. ft. nominal density.
 2. Mineral-Fiber Board: 2 inches thick and 3-lb/cu. ft. nominal density.
- G. Concealed, supply-air plenum insulation shall be one of the following:
1. Mineral-Fiber Blanket: 2 inches thick and 1.5-lb/cu. ft. nominal density.
 2. Mineral-Fiber Board: 2 inches thick and 3-lb/cu. ft. nominal density.
- H. Concealed, return-air plenum insulation shall be one of the following:
1. Mineral-Fiber Board: 2 inches thick and 3-lb/cu. ft. nominal density.
- I. Exposed, round and flat-oval, supply-air duct insulation shall be one of the following:
1. Mineral-Fiber Blanket: 3 inches thick and 3-lb/cu. ft. nominal density.
- J. Exposed, round and flat-oval, return-air duct insulation shall be one of the following:
1. Mineral-Fiber Blanket: 2 inches thick and 1.5-lb/cu. ft..
- K. Exposed, rectangular, supply-air duct insulation shall be one of the following:
1. Mineral-Fiber Blanket: 2 inches thick and 1.5-lb/cu. ft. nominal density.
 2. Mineral-Fiber Board: 2 inches thick and 3-lb/cu. ft. nominal density.

- L. Exposed, rectangular, return-air duct insulation shall be one of the following:
 - 1. Mineral-Fiber Blanket: 2 inches thick and 1.5-lb/cu. ft. nominal density.
 - 2. Mineral-Fiber Board: 2 inches thick and 3-lb/cu. ft. nominal density.
- M. Exposed, supply-air plenum insulation shall be one of the following:
 - 1. Mineral-Fiber Board: 2 inches thick and 3-lb/cu. ft. nominal density.
- N. Exposed, return-air plenum insulation shall be one of the following:
 - 1. Mineral-Fiber Board: 2 inches thick and 3-lb/cu. ft. nominal density.

3.18 EQUIPMENT INSULATION SCHEDULE

- A. Insulation materials and thicknesses are identified below. If more than one material is listed for a type of equipment, selection from materials listed is Contractor's option.
- B. Insulate indoor and outdoor equipment in paragraphs below that is not factory insulated.
- C. Chillers: Insulate cold surfaces on chillers, including, but not limited to, evaporator bundles, condenser bundles, heat-recovery bundles, suction piping, compressor inlets, tube sheets, water boxes, and nozzles with one of the following:
 - 1. Cellular Glass: 2 inches thick.
 - 2. Mineral-Fiber Board: 1 inch thick and 6-lb/cu. ft. nominal density.
 - 3. Mineral-Fiber Pipe and Tank: 1 inch thick.
- D. Heat-exchanger (water-to-water for cooling service) insulation shall be one of the following:
 - 1. Cellular Glass: 2 inches thick.
 - 2. Mineral-Fiber Board: 1 inch thick and 3-lb/cu. ft. nominal density.
 - 3. Mineral-Fiber Pipe and Tank: 1 inch thick.
- E. Heat-exchanger (water-to-water for heating service) insulation shall be one of the following:
 - 1. Cellular Glass: 3 inches thick.
 - 2. Mineral-Fiber Board: 2 inches thick and 6-lb/cu. ft. nominal density.
 - 3. Mineral-Fiber Pipe and Tank: 2 inches thick.
- F. Steam-to-hot-water converter insulation shall be one of the following:
 - 1. Cellular Glass: 3 inches thick.

2. Mineral-Fiber Board: 2 inches thick and 6-lb/cu. ft. nominal density.
 3. Mineral-Fiber Pipe and Tank: 2 inches thick.
- G. Hot-water-to-steam converter insulation shall be one of the following:
1. Cellular Glass: 3 inches thick.
 2. Mineral-Fiber Board: 2 inches thick and 6-lb/cu. ft. nominal density.
 3. Mineral-Fiber Pipe and Tank: 2 inches thick.
- H. Chilled-water pump insulation shall be one of the following:
1. Cellular Glass: 3 inches thick.
 2. Mineral-Fiber Board: 2 inches thick and 6-lb/cu. ft. nominal density.
- I. Condenser-water pump insulation shall be one of the following:
1. Cellular Glass: 2 inches thick.
 2. Mineral-Fiber Board: 1 inch thick and 6-lb/cu. ft. nominal density.
- J. Dual-service heating and cooling pump insulation shall be one of the following:
1. Cellular Glass: 3 inches thick.
 2. Mineral-Fiber Board: 2 inches thick and 6-lb/cu. ft. nominal density.
- K. Heating-hot-water pump insulation shall be one of the following:
1. Cellular Glass: 3 inches thick.
 2. Mineral-Fiber Board: 2 inches thick and 6-lb/cu. ft. nominal density.
- L. Heat-recovery pump insulation shall be one of the following:
1. Cellular Glass: 2 inches thick.
 2. Mineral-Fiber Board: 2 inches thick and 6-lb/cu. ft. nominal density.
- M. Steam condensate pump and boiler feedwater pump insulation shall be one of the following:
1. Cellular Glass: 3 inches thick.
 2. Mineral-Fiber Board: 2 inches thick and 6-lb/cu. ft. nominal density.
 3. Mineral-Fiber Pipe and Tank: 2 inches thick.
- N. Chilled-water expansion/compression tank insulation shall be one of the following:

1. Cellular Glass: 1-1/2 inches thick.
 2. Mineral-Fiber Board: 1 inch thick and 6-lb/cu. ft. nominal density.
 3. Mineral-Fiber Pipe and Tank: 1 inch thick.
- O. Condenser-water expansion/compression tank insulation shall be one of the following:
1. Cellular Glass: 1-1/2 inches thick.
 2. Mineral-Fiber Board: 1 inch thick and 6-lb/cu. ft. nominal density.
 3. Mineral-Fiber Pipe and Tank: 1 inch thick.
- P. Dual-service heating and cooling expansion/compression tank insulation shall be one of the following:
1. Cellular Glass: 1-1/2 inches thick.
 2. Mineral-Fiber Board: 1 inch thick and 6-lb/cu. ft. nominal density.
 3. Mineral-Fiber Pipe and Tank: 1 inch thick.
- Q. Heating-hot-water expansion/compression tank insulation shall be one of the following:
1. Cellular Glass: 1-1/2 inches thick.
 2. Mineral-Fiber Board: 1 inch thick and 6-lb/cu. ft. nominal density.
 3. Mineral-Fiber Pipe and Tank: 1 inch thick.
- R. Heat-recovery expansion/compression tank insulation shall be one of the following:
1. Cellular Glass: 1-1/2 inches thick.
 2. Mineral-Fiber Board: 1 inch thick and 6-lb/cu. ft. nominal density.
 3. Mineral-Fiber Pipe and Tank: 1 inch thick.
- S. Chilled-water air-separator insulation shall be one of the following:
1. Cellular Glass: 2 inches thick.
 2. Mineral-Fiber Board: 1 inch thick and 6-lb/cu. ft. nominal density.
 3. Mineral-Fiber Pipe and Tank: 1 inch thick.
- T. Condenser-water air-separator insulation shall be one of the following:
1. Cellular Glass: 2 inches thick.

2. Mineral-Fiber Board: 1 inch thick and 6-lb/cu. ft. nominal density.
 3. Mineral-Fiber Pipe and Tank: 1 inch thick.
- U. Dual-service heating and cooling air-separator insulation shall be one of the following:
1. Cellular Glass: 2 inches thick.
 2. Mineral-Fiber Board: 1 inch thick and 6-lb/cu. ft. nominal density.
 3. Mineral-Fiber Pipe and Tank: 1 inch thick.
- V. Heating-hot-water air-separator insulation shall be one of the following:
1. Cellular Glass: 3 inches thick.
 2. Mineral-Fiber Board: 2 inches thick and 6-lb/cu. ft. nominal density.
 3. Mineral-Fiber Pipe and Tank: 2 inches thick.
- W. Heat-recovery air-separator insulation shall be one of the following:
1. Cellular Glass: 2 inches thick.
 2. Mineral-Fiber Board: 1 inch thick and 6-lb/cu. ft. nominal density.
 3. Mineral-Fiber Pipe and Tank: 1 inch thick.
- X. Thermal storage tank (brine, water, ice) insulation shall be one of the following:
1. Cellular Glass: 4 inches thick.
 2. Mineral-Fiber Board: 3 inches thick and 6-lb/cu. ft. nominal density.
 3. Mineral-Fiber Pipe and Tank: 3 inches thick.
- Y. Deaerator insulation shall be one of the following:
1. Cellular Glass: 3 inches thick.
 2. Mineral-Fiber Board: 2 inches thick and 6-lb/cu. ft. nominal density.
 3. Mineral-Fiber Pipe and Tank: 2 inches thick.
- Z. Steam condensate tank and receiver insulation shall be one of the following:
1. Cellular Glass: 3 inches thick.
 2. Mineral-Fiber Board: 2 inches thick and 6-lb/cu. ft. nominal density.
 3. Mineral-Fiber Pipe and Tank: 2 inches thick.

AA. Steam flash-tank, flash-separator, and blow-off-tank insulation shall be one of the following:

1. Cellular Glass: 3 inches thick.
2. Mineral-Fiber Board: 2 inches thick and 6-lb/cu. ft. nominal density.
3. Mineral-Fiber Pipe and Tank: 2 inches thick.

BB. Piping system filter-housing insulation shall be one of the following:

1. Cellular Glass: 3 inches thick.
2. Mineral-Fiber Board: 2 inches thick and 6-lb/cu. ft. nominal density.
3. Mineral-Fiber Pipe and Tank: 2 inches thick.

CC. Outdoor, aboveground, heated, fuel-oil storage tank insulation shall be one of the following:

1. Cellular Glass: 3 inches thick.
2. Mineral-Fiber Board: 2 inches thick and 6-lb/cu. ft. nominal density.
3. Mineral-Fiber Pipe and Tank: 2 inches thick.

3.19 PIPING INSULATION SCHEDULE, GENERAL

- A. Acceptable preformed pipe and tubular insulation materials and thicknesses are identified for each piping system and pipe size range. If more than one material is listed for a piping system, selection from materials listed is Contractor's option.
- B. For interior piping and ductwork sealing a water based mastic shall be utilized.
- C. Items Not Insulated: Unless otherwise indicated, do not install insulation on the following:
 1. Drainage piping located in crawl spaces.
 2. Underground piping.
 3. Chrome-plated pipes and fittings unless there is a potential for personnel injury.

3.20 INDOOR PIPING INSULATION SCHEDULE

- A. Condensate and Equipment Drain Water below 60 Deg F:
 1. All Pipe Sizes: Insulation shall be one of the following:
 - a. Cellular Glass: 1-1/2 inches thick.
 - b. Mineral-Fiber, Preformed Pipe Insulation, Type I: 1 inch thick.

- B. Condenser-Water Supply and Return:
 - 1. All Pipe Sizes: Insulation shall be one of the following:
 - a. Cellular Glass: 1-1/2 inches thick.
 - b. Flexible Elastomeric: 1-1/2 inches thick.
 - c. Mineral-Fiber, Preformed Pipe Insulation, Type I: 1 inches thick.
- C. Chilled Water and Brine, 40 Deg F and below:
 - 1. NPS 3 and Smaller: Insulation shall be one of the following:
 - a. Cellular Glass: 2 inches thick.
 - b. Mineral-Fiber, Preformed Pipe, Type I 2 inches thick.
 - 2. NPS 4 to NPS 12: Insulation shall be one of the following:
 - a. Cellular Glass: 2 inches thick.
 - b. Mineral-Fiber, Preformed Pipe, Type I2 inches thick.
 - 3. NPS 14 and Larger: Insulation shall be one of the following:
 - a. Cellular Glass: 3 inches thick.
 - b. Mineral-Fiber, Preformed Pipe, Type I 3 inches thick.
- D. Chilled Water and Brine, above 40 Deg F:
 - 1. NPS 12 and Smaller: Insulation shall be one of the following:
 - a. Cellular Glass: 2 inches thick.
 - b. See Evaluations for discussion of pipe insulation wicking system.
 - c. Mineral-Fiber, Preformed Pipe, Type I 2 inches thick.
- E. Heating-Hot-Water Supply and Return, above 200 Deg F:
 - 1. NPS 3/4 and Smaller: Insulation shall be one of the following:
 - a. Cellular Glass: 2 inches thick.
 - b. Mineral-Fiber, Preformed Pipe, Type I or II: 2 inches thick.
 - 2. NPS 1 and Larger: Insulation shall be one of the following:
 - a. Cellular Glass: 2 inches thick.

- b. Mineral-Fiber, Preformed Pipe, Type I or II: 2 inches thick.
- F. Steam and Steam Condensate, 350 Deg F and below:
 - 1. NPS 1 and Smaller: Insulation shall be one of the following:
 - a. Mineral-Fiber, Preformed Pipe, Type I or II: 2 inches thick.
 - 2. NPS 1-1/4 and Larger: Insulation shall be one of the following:
 - a. Mineral-Fiber, Preformed Pipe, Type I or II: 2-1/2 inches thick.
- G. Steam and Steam Condensate, above 350 Deg F:
 - 1. NPS 3/4 and Smaller: Insulation shall be one of the following:
 - a. Calcium Silicate: 2 inches thick.
 - b. Cellular Glass: 2 inches thick.
 - c. Mineral-Fiber, Preformed Pipe, Type I or II: 2 inches thick.
 - 2. NPS 1 and Larger: Insulation shall be one of the following:
 - a. Cellular Glass: 3 inches thick.
 - b. Mineral-Fiber, Preformed Pipe, Type I or II: 3 inches thick.
- H. Refrigerant Suction and Hot-Gas Piping:
 - 1. All Pipe Sizes: Insulation shall be one of the following:
 - a. Cellular Glass: 1-1/2 inches thick.
 - b. Flexible Elastomeric: 1 inch thick.
 - c. Mineral-Fiber, Preformed Pipe Insulation, Type I: 1 inch thick.
- I. Refrigerant Suction and Hot-Gas Flexible Tubing:
 - 1. All Pipe Sizes: Insulation shall be one of the following:
 - a. Flexible Elastomeric: 1 inch thick.
 - b. Polyolefin: 1 inch thick.
- J. Heat-Recovery Piping:
 - 1. All Pipe Sizes: Insulation shall be one of the following:
 - a. Cellular Glass: 1-1/2 inches thick.

- b. Mineral-Fiber, Preformed Pipe Insulation, Type I: 1 inch thick.

K. Hot Service Drains:

- 1. All Pipe Sizes: Insulation shall be one of the following:

- a. Cellular Glass: 1-1/2 inches thick.
- b. Mineral-Fiber, Preformed Pipe, Type I or II: 1 inch thick.

L. Hot Service Vents:

- 1. All Pipe Sizes: Insulation shall be one of the following:

- a. Cellular Glass: 1-1/2 inches thick.
- b. Mineral-Fiber, Preformed Pipe, Type I or II: 1 inch thick.

3.21 OUTDOOR, ABOVEGROUND PIPING INSULATION SCHEDULE

A. Chilled Water and Brine:

- 1. All Pipe Sizes: Insulation shall be one of the following:

- a. Cellular Glass: 3 inches thick.
- b. Flexible Elastomeric: 3 inches thick.
- c. Mineral-Fiber, Preformed Pipe Insulation, Type I: 3 inches thick.

B. Condenser-Water Supply and Return:

- 1. All Pipe Sizes: Insulation shall be one of the following:

- a. Cellular Glass: 2 inches thick.
- b. Flexible Elastomeric: 2 inches thick.
- c. Mineral-Fiber, Preformed Pipe Insulation, Type I: 1 inches thick.

C. Chilled Beam Supply:

- 1. All Pipe Sizes: Insulation shall be one of the following:

- a. Flexible Elastomeric: 1 inches thick.
- b. Mineral-Fiber, Preformed Pipe Insulation, Type I: 1 inches thick.

- 2. Chilled beam return may be un-insulated.

- D. Heating-Hot-Water Supply and Return, 200 Deg F and below:
 - 1. All Pipe Sizes: Insulation shall be one of the following:
 - a. Cellular Glass: 3 inches thick.
 - b. Mineral-Fiber, Preformed Pipe Insulation, Type I: 2 inches thick.
- E. Heating-Hot-Water Supply and Return, above 200 Deg F:
 - 1. All Pipe Sizes: Insulation shall be one of the following:
 - a. Cellular Glass: 3 inches thick.
 - b. Mineral-Fiber, Preformed Pipe Insulation, Type I or II: 2 inches thick.
- F. Steam and Steam Condensate, 350 Deg F and below:
 - 1. All Pipe Sizes: Insulation shall be one of the following:
 - a. Cellular Glass: 4 inches thick.
 - b. Mineral-Fiber, Preformed Pipe Insulation, Type I or II: 3 inches thick.
- G. Steam and Steam Condensate, above 350 Deg F:
 - 1. All Pipe Sizes: Insulation shall be one of the following:
 - a. Cellular Glass: 5 inches thick.
 - b. Mineral-Fiber, Preformed Pipe Insulation, Type I or II: 4 inches thick.
- H. Refrigerant Suction and Hot-Gas Piping:
 - 1. All Pipe Sizes: Insulation shall be one of the following:
 - a. Cellular Glass: 2 inches thick.
 - b. Flexible Elastomeric: 2 inches thick.
 - c. Mineral-Fiber, Preformed Pipe Insulation, Type I: 2 inches thick.
- I. Refrigerant Suction and Hot-Gas Flexible Tubing:
 - 1. All Pipe Sizes: Insulation shall be one of the following:
 - a. Flexible Elastomeric: 2 inches thick.
- J. Heat-Recovery Piping:
 - 1. All Pipe Sizes: Insulation shall be one of the following:

- a. Cellular Glass: 2 inches thick.
- b. Flexible Elastomeric: 2 inches thick.
- c. Mineral-Fiber, Preformed Pipe Insulation, Type I: 2 inches thick.

K. Dual-Service Heating and Cooling:

- 1. All Pipe Sizes: Insulation shall be one of the following:
 - a. Cellular Glass: 3 inches thick.
 - b. Mineral-Fiber, Preformed Pipe Insulation, Type I: 2 inches thick.

L. Hot Service Drains:

- 1. All Pipe Sizes: Insulation shall be one of the following:
 - a. Calcium Silicate: 1-1/2 inches thick.
 - b. Cellular Glass: 1-1/2 inches thick.
 - c. Mineral-Fiber, Preformed Pipe Insulation, Type I: 1 inch thick.

M. Hot Service Vents:

- 1. All Pipe Sizes: Insulation shall be one of the following:
 - a. Cellular Glass: 1-1/2 inches thick.
 - b. Mineral-Fiber, Preformed Pipe Insulation, Type II: 1 inch thick.

3.22 OUTDOOR, UNDERGROUND PIPING INSULATION SCHEDULE

- A. Chilled Water, All Sizes: Cellular glass, 2 inches thick.
- B. Condenser-Water Supply and Return, All Sizes: Cellular glass, 2 inches thick.
- C. Heating-Hot-Water Supply and Return, All Sizes, 200 Deg F and below: Cellular glass, 3 inches thick.
- D. Heating-Hot-Water Supply and Return, All Sizes, above 200 Deg F:
 - 1. Cellular Glass: 3 inches thick.
- E. Steam and Steam Condensate, All Sizes, 350 Deg F and below:
 - 1. Cellular Glass: 4 inches thick.
- F. Steam and Steam Condensate, All Sizes, above 350 Deg F:

1. Cellular Glass: 5 inches thick.

G. Dual-Service Heating and Cooling, All Sizes, 40 to 200 Deg F: Cellular glass, 3 inches thick.

3.23 INDOOR, FIELD-APPLIED JACKET SCHEDULE

A. Install jacket over insulation material. For insulation with factory-applied jacket, install the field-applied jacket over the factory-applied jacket. Refer to specification section 230553 Identification for HVAC Piping and Equipment for service identification and jacket colors.

B. If more than one material is listed, selection from materials listed is Contractor's option.

C. Ducts and Plenums, Concealed:

1. PVC: 20 mils thick.

2. Aluminum, Smooth: 0.020 inch thick.

3. Painted Aluminum, Smooth: 0.020 inch thick.

D. Ducts and Plenums, Exposed:

1. PVC: 20 mils thick.

2. Aluminum, Smooth: 0.020 inch thick.

3. Painted Aluminum, Smooth: 0.020 inch thick.

E. Equipment, Concealed:

1. Aluminum, Corrugated: 0.032 inch thick.

2. Painted Aluminum, Corrugated: 0.032 inch thick.

F. Equipment, Exposed, up to 48 Inches in Diameter or with Flat Surfaces up to 72 Inches:

1. Aluminum, Corrugated: 0.032 inch thick.

2. Painted Aluminum, Corrugated: 0.032 inch thick.

G. Piping, Concealed:

1. PVC: 20 mils thick.

2. Aluminum, Smooth: 0.020 inch thick.

3. Painted Aluminum, Smooth: 0.020 inch thick.

H. Piping, Exposed:

1. Aluminum, Smooth: 0.020 inch thick.
2. Painted Aluminum, Smooth: 0.020 inch thick.

3.24 OUTDOOR, FIELD-APPLIED JACKET SCHEDULE

- A. Install jacket over insulation material. For insulation with factory-applied jacket, install the field-applied jacket over the factory-applied jacket.
- B. If more than one material is listed, selection from materials listed is Contractor's option.
- C. Ducts and Plenums, Concealed:
 1. None.
 2. PVC: 30 mils thick.
 3. Aluminum, Smooth: 0.024 inch thick.
 4. Painted Aluminum, Smooth: 0.016 inch 0.024 inch thick.
- D. Ducts and Plenums, Exposed, up to 48 Inches in Diameter or with Flat Surfaces up to 72 Inches:
 1. Aluminum, Corrugated: 0.032 inch thick.
 2. Painted Aluminum, Corrugated: 0.032 inch thick.
- E. Ducts and Plenums, Exposed, Larger Than 48 Inches in Diameter or with Flat Surfaces Larger Than 72 Inches:
 1. Painted Aluminum, Stucco Embossed with 2-1/2-Inch- Deep Corrugations Box Ribs: 0.040 inch thick.
- F. Equipment, Concealed:
 1. PVC: 30 mils thick.
 2. Aluminum, Smooth: 0.024 inch thick.
 3. Painted Aluminum, Smooth: 0.024 inch thick.
- G. Equipment, Exposed, up to 48 Inches in Diameter or with Flat Surfaces up to 72 Inches:
 1. Painted Aluminum, Smooth with Z-Shaped Locking Seam: 0.024 inch thick.
- H. Equipment, Exposed, Larger Than 48 Inches in Diameter or with Flat Surfaces Larger Than 72 Inches:
 1. Painted Aluminum, 2-1/2-Inch- Deep Corrugations Box Ribs: 0.040 inch thick.

- I. Piping, Concealed:
 - 1. PVC: 20 mils thick.
 - 2. Aluminum, Smooth: 0.024 inch thick.
 - 3. Painted Aluminum, Smooth: 0.024 inch thick.

- J. Piping, Exposed:
 - 1. PVC: 30 mils thick.
 - 2. Painted Aluminum, Smooth with Z-Shaped Locking Seam: 0.024 inch thick.

3.25 UNDERGROUND, FIELD-INSTALLED INSULATION JACKET

- A. For underground direct-buried piping applications, install underground direct-buried jacket over insulation material.

END OF SECTION 230700

SECTION 230800 - COMMISSIONING OF HVAC

PART 1 - GENERAL

1.1 RELATED DOCUMENTS

- A. Drawings and general provisions of the Contract, including General and Supplementary Conditions and other Division 01 Specification Sections, apply to this Section.

1.2 SUMMARY

- A. Section includes commissioning process requirements for HVAC&R systems, assemblies, and equipment.
- B. Related Sections:
 - 1. Division 01 Section "General Commissioning Requirements" for general commissioning process requirements.

1.3 DEFINITIONS

- A. Commissioning Plan: A document that outlines the organization, schedule, allocation of resources, and documentation requirements of the commissioning process.
- B. CxA: Commissioning Authority.
- C. HVAC&R: Heating, Ventilating, Air Conditioning, and Refrigeration.
- D. Systems, Subsystems, Equipment, and Components: Where these terms are used together or separately, they shall mean "as-built" systems, subsystems, equipment, and components.

1.4 ALLOWANCES

- A. Labor, instrumentation, tools, and equipment costs for technicians for the performance of commissioning testing are covered by the "Schedule of Allowances" Article in Division 01 Section "Allowances."

1.5 UNIT PRICES

- A. Commissioning testing allowance may be adjusted up or down by the "List of Unit Prices" Article in Division 01 Section "Unit Prices" when actual man-hours are computed at the end of commissioning testing.

1.6 CONTRACTOR'S RESPONSIBILITIES

- A. Perform commissioning tests at the direction of the CxA.
- B. Attend construction phase controls coordination meeting.
- C. Attend testing, adjusting, and balancing review and coordination meeting.
- D. Participate in HVAC&R systems, assemblies, equipment, and component maintenance orientation and inspection as directed by the CxA.
- E. Provide information requested by the CxA for final commissioning documentation.
- F. Provide measuring instruments and logging devices to record test data, and provide data acquisition equipment to record data for the complete range of testing for the required test period.

1.7 CxA'S RESPONSIBILITIES

- A. Provide Project-specific construction checklists and commissioning process test procedures for actual HVAC&R systems, assemblies, equipment, and components to be furnished and installed as part of the construction contract.
- B. Direct commissioning testing.
- C. Verify testing, adjusting, and balancing of Work are complete.
- D. Provide test data, inspection reports, and certificates in Systems Manual.

1.8 COMMISSIONING DOCUMENTATION

- A. Provide the following information to the CxA for inclusion in the commissioning plan:
 - 1. Plan for delivery and review of submittals, systems manuals, and other documents and reports.
 - 2. Identification of installed systems, assemblies, equipment, and components including design changes that occurred during the construction phase.
 - 3. Process and schedule for completing construction checklists and manufacturer's prestart and startup checklists for HVAC&R systems, assemblies, equipment, and components to be verified and tested.
 - 4. Certificate of completion certifying that installation, prestart checks, and startup procedures have been completed.
 - 5. Certificate of readiness certifying that HVAC&R systems, subsystems, equipment, and associated controls are ready for testing.
 - 6. Test and inspection reports and certificates.
 - 7. Corrective action documents.
 - 8. Verification of testing, adjusting, and balancing reports.

9. Training schedule with completion dates, training agendas, list of training materials and sign in sheets.

1.9 SUBMITTALS

- A. Certificates of readiness.
- B. Certificates of completion of installation, prestart, and startup activities.
- C. Commissioning Plan
 1. Commissioning Plan shall identify systems in the contract documents to be tested. Scope of HVAC&R testing shall include entire HVAC&R installation, from central equipment for heat generation and refrigeration through distribution systems to each conditioned space. Testing shall include measuring capacities and effectiveness of operational and control functions. At a minimum the following systems should be included as applicable for the project:
 - a. Air Handling Equipment and associated exhaust or return fans.
 - b. Humidification equipment.
 - c. Terminal Heating /Cooling units (Supply and Return/Exhaust VAV's, FCU's, Chilled Beams, Unit Heaters, etc.)
 - d. Fume hoods
 - e. Chilled water plant equipment including pumps and heat exchangers
 - f. Refrigerant Monitor and associated fans.
 - g. Heating water plant equipment including pumps and heat exchangers
 - h. Meters (include scaling and integration to BAS).
 - i. Water heaters and plumbing pumps
 - j. Building Automation System
- D. Prefunctional Tests
- E. Functional Performance Tests
- F. Final Cx Report
 1. Final Cx Report shall provide a summary of project and at minimum include the following sections:
 - a. Start up reports for equipment indicated to be tested.
 - b. Duct and piping pressure test reports, weld inspection reports
 - c. Site Visit Reports by CxA
 - d. Prefunctional test checklists
 - e. Functional Performance tests with a separate cover indicating exceptions taken during field testing.
 - f. Deficiency log with disposition on each item.
 - g. Final Testing and Balancing report
 - h. Warranty Certificates

PART 2 - PRODUCTS (Not Used)

PART 3 - EXECUTION

3.1 TESTING PREPARATION

- A. Certify that HVAC&R systems, subsystems, and equipment have been installed, calibrated, and started and are operating according to the Contract Documents.
- B. Certify that HVAC&R instrumentation and control systems have been completed and calibrated, that they are operating according to the Contract Documents, and that pretest set points have been recorded.
- C. Certify that testing, adjusting, and balancing procedures have been completed and that testing, adjusting, and balancing reports have been submitted, discrepancies corrected, and corrective work approved.
- D. Set systems, subsystems, and equipment into operating mode to be tested (e.g., normal shutdown, normal auto position, normal manual position, unoccupied cycle, emergency power, and alarm conditions).
- E. Inspect and verify the position of each device and interlock identified on checklists.
- F. Ensure communication between each device on the pint list and establish trends and alarms for points identified. Trends to be available to CxA during Functional Performance Tests.
- G. Check safety cutouts, alarms, and interlocks with smoke control and life-safety systems during each mode of operation.
- H. Testing Instrumentation: Install measuring instruments and logging devices to record test data as directed by the CxA.

3.2 Testing AND BALANCING VERIFICATION

- A. Prior to performance of testing and balancing Work, provide copies of reports, sample forms, checklists, and certificates to the CxA.
- B. Notify the CxA at least 10 days in advance of testing and balancing Work, and provide access for the CxA to witness testing and balancing Work.
- C. Provide technicians, instrumentation, and tools to verify testing and balancing of HVAC&R systems at the direction of the CxA.
 - 1. The CxA will notify testing and balancing Contractor 10 days in advance of the date of field verification. Notice will not include data points to be verified.
 - 2. The testing and balancing Contractor shall use the same instruments (by model and serial number) that were used when original data were collected.

3. Failure of an item includes, other than sound, a deviation of more than 10 percent. Failure of more than 10 percent of selected items shall result in rejection of final testing, adjusting, and balancing report. For sound pressure readings, a deviation of 3 dB shall result in rejection of final testing. Variations in background noise must be considered.
4. Remedy the deficiency and notify the CxA so verification of failed portions can be performed.

3.3 GENERAL TESTING REQUIREMENTS

- A. Provide technicians, instrumentation, and tools to perform commissioning test at the direction of the CxA.
- B. Verify that access is provided for inspection, operation and repair / replacement of equipment.
- C. Verify all gages and test ports are provided as required by contract documents and manufacturer's recommendations.
- D. Verify that all monitoring is active and ensure all alarms are set by Owner's Requirements.
- E. Test all operating modes, interlocks, control responses, and responses to abnormal or emergency conditions, and verify proper response of building automation system controllers and sensors.
- F. The CxA along with the HVAC&R ContractorS, testing and balancing [Contractor], and HVAC&R Instrumentation and Control [Contractor] shall prepare detailed testing plans, procedures, and checklists for HVAC&R systems, subsystems, and equipment.
- G. Tests will be performed using design conditions whenever possible.
- H. Simulated conditions may need to be imposed using an artificial load when it is not practical to test under design conditions. Before simulating conditions, calibrate testing instruments. Provide equipment to simulate loads. Set simulated conditions as directed by the CxA and document simulated conditions and methods of simulation. After tests, return settings to normal operating conditions.
- I. The CxA may direct that set points be altered when simulating conditions is not practical.
- J. The CxA may direct that sensor values be altered with a signal generator when design or simulating conditions and altering set points are not practical.
- K. If tests cannot be completed because of a deficiency outside the scope of the HVAC&R system, document the deficiency and report it to the Owner. After deficiencies are resolved, reschedule tests.
- L. If the testing plan indicates specific seasonal testing, complete appropriate initial performance tests and documentation and schedule seasonal tests.

3.4 HVAC&R SYSTEMS, SUBSYSTEMS, AND EQUIPMENT TESTING PROCEDURES

- A. HVAC&R Instrumentation and Control System Testing: Field testing plans and testing requirements are specified in Division 23 Sections "Direct Digital Control (DDC) for HVAC." Assist the CxA with preparation of testing plans.
- B. Pipe system cleaning, flushing, hydrostatic tests, and chemical treatment requirements are specified in Division 23 "Hydronic Piping" Sections. HVAC&R Contractor shall prepare a pipe system cleaning, flushing, and hydrostatic testing plan. Provide cleaning, flushing, testing, and treating plan and final reports to the CxA. Plan shall include the following:
 - 1. Sequence of testing and testing procedures for each section of pipe to be tested, identified by pipe zone or sector identification marker. Markers shall be keyed to Drawings for each pipe sector, showing the physical location of each designated pipe test section. Drawings keyed to pipe zones or sectors shall be formatted to allow each section of piping to be physically located and identified when referred to in pipe system cleaning, flushing, hydrostatic testing, and chemical treatment plan.
 - 2. Description of equipment for flushing operations.
 - 3. Minimum flushing water velocity.
 - 4. Tracking checklist for managing and ensuring that all pipe sections have been cleaned, flushed, hydrostatically tested, and chemically treated.
- C. Energy Supply System Testing: Provide technicians, instrumentation, tools, and equipment to test performance of steam systems and equipment at the direction of the CxA. The CxA shall determine the sequence of testing and testing procedures for each equipment item and pipe section to be tested.
- D. Refrigeration System Testing: Provide technicians, instrumentation, tools, and equipment to test performance of chillers, cooling towers, refrigerant compressors and condensers, heat pumps, and other refrigeration systems. The CxA shall determine the sequence of testing and testing procedures for each equipment item and pipe section to be tested.
- E. HVAC&R Distribution System Testing: Provide technicians, instrumentation, tools, and equipment to test performance of air, steam, and hydronic distribution systems; special exhaust; and other distribution systems, including HVAC&R terminal equipment and unitary equipment.
- F. Vibration and Sound Tests: Provide technicians, instrumentation, tools, and equipment to test performance of vibration isolation and seismic controls.

3.5 BUILDING AUTOMATION SYSTEM TESTING REQUIREMENTS

- A. Provide technicians, instrumentation, and tools to perform commissioning test at the direction of the CxA.
- B. Operate System for Two Weeks Successfully prior to Functional Performance Testing.
 - 1. BAS shall be accessible by owner and Cx agent on Campus server 2-weeks prior to FPT to allow trend accumulation and storage.

2. Leading up to FPT system should operate continuously successfully for two-weeks and this should be demonstrated by trend data that is accessible to the owner and Cx agent on the Campus BAS server.
 3. On past projects CM has completed building Network Closets in advance of testing to allow connectivity to campus BAS server or has setup temporary network connection via cellular network or from nearby campus building.
- C. BAS Start-Up Testing, Adjusting and Calibration
1. Work and/or systems installed under this Division shall be fully functioning prior to Demonstration and Acceptance Phase. Contractor shall start, test, adjust, and calibrate all work and/or systems under this Contract, as described below:
 - a. Inspect the installation of all devices. Review the manufacturer's installation instructions and validate that the device is installed in accordance.
 - b. Verify proper electrical voltages and amperages, and verify that all circuits are free from faults.
 - c. Verify integrity/safety of all electrical connections.
 - d. Coordinate with TAB subcontractor to obtain and CxT to fine tune control settings that are determined from balancing procedures. Record the following control settings as obtained from TAB contractor, and note any TAB deficiencies in the commissioning application:
 - 1) Optimum duct static pressure setpoints for VAV air handling units.
 - 2) Minimum outside air damper settings for air handling units.
 - 3) Calibration parameters for flow control devices such as VAV boxes and flow measuring stations.
 - e. Test, calibrate, and set all digital and analog sensing, and actuating devices. Calibrate each instrumentation device by making a comparison between the BAS display and the reading at the device, using an instrument traceable to the National Bureau of Standards, which shall be at least twice as accurate as the device to be calibrated (e.g., if field device is +/-0.5% accurate, test equipment shall be +/-0.25% accurate over same range). Record the measured value and displayed value for each device in the BAS/LC Pre-Commissioning Report.
 - f. Check and set zero and span adjustments for all transducers and transmitters.
 - g. For Dampers and Valves:
 - 1) check for adequate installation including free travel throughout range and adequate seal
 - 2) where loops are sequenced, check for proper control without overlap
 - h. For Actuators:
 - 1) Check to insure that device seals tightly when the appropriate signal is applied to the operator at full anticipated system pressures.
 - 2) Check for appropriate fail position, and that the stroke and range is as required
 - 3) For pneumatic operators, adjust the operator spring compression as required to achieve close off. If positioner or volume booster is installed on the operator, calibrate per manufacturer's procedure to achieve spring range indicated. Check split range positioners to verify proper operation. Record settings for each device.
 - 4) For sequenced electronic actuators, calibrate per manufacturer's instructions to required ranges
 - i. Check each digital control point by making a comparison between the control command at the CU and the status of the controlled device. Check each digital

- input point by making a comparison of the state of the sensing device and the OI display. Record the results for each device.
- j. For outputs to reset other manufacturer's devices (VSDs, etc) and feedback from them, calibrate ranges to establish proper parameters. Coordinate with representative of the respective manufacturer and obtain their approval of the installation.
 - k. Verify proper sequences and document testing in Cx application.
 - l. Verify all safety devices trip at appropriate conditions. Adjust setpoints accordingly.
 - m. Tune all control loops to obtain the fastest stable response without hunting, offset or overshoot. Record tuning parameters and response test results for each control loop in the Cx application. Except from a startup, maximum allowable variance from set point for controlled variables under normal load fluctuations shall be as follows. Within 3 minutes of any upset (for which the system has the capability to respond to) in the control loop, tolerances shall be maintained (exceptions noted):
 - 1) Duct air temperature: $\pm 1^{\circ}\text{F}$.
 - 2) Space Temperature: $\pm 1^{\circ}\text{F}$
 - 3) Duct pressure: $\pm 0.2''$ w.g.
 - 4) Space Pressure: $\pm 0.01''$ w.g.
 - 5) Water pressure: ± 1 psid
 - 6) Duct or space Humidity: $\pm 3\%$
 - 7) Air flow control: $\pm 10\%$ of full scale.
 - n. For communication interfaces and BAS control panels:
 - 1) Ensure devices are properly installed with adequate clearance for maintenance and clearly labeled in accordance with the record drawings
 - 2) Ensure terminations are safe, secure and labeled in accordance with the record drawings
 - 3) Check power supplies for proper voltage ranges and loading.
 - 4) Ensure wiring and tubing are run in a neat and workman-like manner, either bound or enclosed in trough. Ensure ambient conditions for pneumatic tubing are commensurate with control air dew point.
 - 5) Check for adequate signal strength on communication networks.
 - 6) Check for stand alone performance of controllers by disconnecting the controller from the LAN. Verify the event is enunciated at OIs. Verify that the controlling LAN reconfigures as specified in the event of a LAN disconnection
 - 7) Ensure all outputs and devices fail to their proper positions/states.
 - 8) Ensure buffered and/ or volatile information is held through power outage
 - 9) With all system and communications operating normally, sample and record update/enunciation times for critical alarms fed from the panel to the OI.
 - 10) Check for adequate grounding of all BAS panels and devices
 - 11) Run self diagnostic routines and ensure they are functional.
 - 12) Check the memory allocation and loading to ensure adequate and excess capacity is available and that it will not affect control functionality.
 - o. For Operator Interfaces:
 - 1) Verify all elements on the graphics are functional and properly bound to physical devices and/or virtual points and that hot links or page jumps are functional and logical.
 - 2) Output all specified BAS reports for review and approval.
 - 3) Verify the alarm printing and logging is functional and per requirements

- 4) Verify trend archiving to disk and provide a sample to the CxA for review
 - 5) Verify paging/dial out alarm enunciation is functional
 - 6) Verify functionality of remote OIs and that a robust connection can be established consistently.
 - 7) Verify that required third party software applications required with the bid are installed and functional.
- p. Verify Proper interface with fire alarm system.
- D. Sensor Checkout and Calibration:
1. Generally, Checkout: Verify that all sensor locations are appropriate and away from causes of erratic operation. Verify that sensors with shielded cable are grounded only at one end. For sensor pairs that are used to determine a temperature or pressure difference, make sure they are reading within 0.2°F of each other for temperature and within a tolerance equal to 2% of the reading, of each other, for pressure. Tolerances for critical applications may be tighter.
 2. Calibration: Calibrate all sensors using one of the following procedures:
 - a. Sensors Without Transmitters--Standard Application. Make a reading with a calibrated test instrument within 6 inches of the site sensor at various points across the range. Verify that the sensor reading (via the permanent thermostat, gage or BAS) is within the tolerances specified for the sensor. If not, adjust offset and range, or replace sensor.
 - b. Sensors With Transmitters--Standard Application. Disconnect sensor. Connect a signal generator in place of sensor. Connect ammeter in series between transmitter and BAS control panel. Using manufacturer's resistance-temperature data, simulate minimum desired temperature. Adjust transmitter potentiometer zero until 4 mA is read by the ammeter. Repeat for the maximum temperature matching 20 mA to the potentiometer span or maximum and verify at the OI. Record all values and recalibrate controller as necessary to conform to tolerances. Reconnect sensor. Make a reading with a calibrated test instrument within 6 inches of the site sensor. Verify that the sensor reading (via the permanent thermostat, gage or BAS) is within the tolerances specified. If not, replace sensor and repeat. For pressure sensors, perform a similar process with a suitable signal generator.
- E. Loop Tuning
1. For all control loops, contractor shall tune the loops to ensure the fastest stable response without hunting, offset or overshoot. Contractor shall introduce upsets to the load when possible to affect response. Otherwise, setpoints can be changed to affect the response.
 2. Generally, tune loops during periods of high gain.
 3. Document all parameters either by capturing text, short interval trends, or screen shots of trend graph documenting the final response.
- F. BAS System Demonstration
1. Demonstrate the operation of the BAS System hardware, software, and all related components and systems to the satisfaction of the CxA and O/O. Schedule the demonstration with the Owner's representative 2 weeks in advance. Demonstration shall not be scheduled until all hardware and software submittals, and the Start-Up Documentation and/or Test Report are approved. If the Work fails to be demonstrated to conform with Contract specifications, so as to require scheduling of additional site visits by the Commissioning Authority for re-demonstration, Contractor shall reimburse Owner for costs of subsequent Commissioning Authority site visits.

2. The Contractor shall supply all personnel and equipment for the demonstration, including, but not limited to, instruments, ladders, etc. Contractor supplied personnel must be competent with and knowledgeable of all project-specific hardware, software, and the HVAC systems. All training documentation and submittals shall be at the job site.
 3. Demonstration shall typically involve small representative samples of systems/equipment randomly selected by the Owner and CxA.
 4. The system shall be demonstrated following the same procedures used in the Start-Up Test by using the approved Commissioning Checklists. Demonstration shall include, but not necessarily be limited to, the following:
 - a. Demonstrate that required software is installed on BAS System workstations. Demonstrate that graphic screens, alarms, trends, and reports are installed as submitted and approved.
 - b. Demonstrate that points specified and shown can be interrogated and/or commanded (as applicable) from all workstations, as specified.
 - c. Demonstrate that remote dial-up communication abilities are in accordance with these Specifications.
 - d. Demonstrate correct calibration of input/output devices using the same methods specified for the start-Up tests. A maximum of 10 percent of I/O points shall be selected at random by Commissioning Authority and/or Owner for demonstration. Upon failure of any device to meet the specified end-to-end accuracy, an additional 10 percent of I/O points shall be selected at random by Commissioning Authority for demonstration. This process shall be repeated until 100 percent of randomly selected I/O points have been demonstrated to meet specified end-to-end accuracy.
 - e. Demonstrate that all BAS and other software programs exist at respective field panels. The Direct Digital Control (BAS) programming and point database shall be as submitted and approved.
 - f. Demonstrate that all BAS programs accomplish the specified sequences of operation.
 - g. Demonstrate that the panels automatically recover from power failures, as specified.
 - h. Demonstrate that the stand-alone operation of panels meets the requirements of these Specifications. Demonstrate that the panels' response to LAN communication failures meets the requirements of these Specifications.
 - i. Identify access to equipment selected by Commissioning Authority. Demonstrate that access is sufficient to perform required maintenance.
 - j. Demonstrate that required trend graphs and trend logs are set up per the requirements. Provide a sample of the data archive. Indicate the file.
 5. BAS System Demonstration shall be completed and approved prior to Substantial Completion.
 6. Any tests successfully completed during the 2 week demonstration time frame will be recorded as passed for the functional performance testing and will not have to be repeated.
- G. Warranty Phase BAS Opposite Season Trending and Testing:
1. Trending: throughout the first year of the Warranty Phase, trend logs shall be maintained as required for the Acceptance Period. Contractor shall forward archived trend logs to the CxA for review upon CxA's request. CxA will review these and notify contractor of any warranty work required.

2. Opposite Season Testing: Within 6 months of completion of the Acceptance Phase, CxA shall schedule and conduct Opposite Season functional performance testing. Contractor shall participate in this testing and remedy any deficiencies identified.

END OF SECTION 230800

SECTION 230923 - DIRECT DIGITAL CONTROL (DDC) SYSTEM FOR HVAC

PART 1 - GENERAL

1.1 RELATED DOCUMENTS

- A. Drawings and general provisions of the Contract, including General and Supplementary Conditions and Division 01 Specification Sections, apply to this Section.

1.2 SUMMARY

A. Section Includes:

1. DDC system for monitoring and controlling of HVAC systems.
2. The purpose of the section is to describe the University of Maryland's Central Control and Monitoring System (CCMS) and Building Automation Systems (BAS). This section is to apply to all new construction and renovation projects that involve automated control of building systems.
3. Delivery of selected control devices to equipment and systems manufacturers for factory installation and to HVAC systems installers for field installation.

B. Related Requirements:

1. Division 23 Section "Energy Meters" for thermal and electric power energy meters that connect to DDC systems.
 - a. Division 26 Section "Low-Voltage Electrical Power Conductors and Cables" for balanced twisted pair communications cable.
2. Raceways:
 - a. Division 26 Section "Raceways and Boxes for Electrical Systems" for raceways for low-voltage control cable.
3. Section 260553 "Identification for Electrical Systems" for identification requirements for electrical components.

1.3 RESPONSIBILITIES:

- A. The BAS Contractor shall be responsible for the following:

1. All wiring from mechanical and electrical alarms and functions to report these alarms and functions to the BAS head-end.
 2. All line and low voltage wiring for the control of all HVAC motors (whether individual or as part of packaged equipment), automatic control valves, and dampers, including: wiring for EPs, PEs, relays, controllers, thermostats, actuating devices, unit heater controls, and cabinet heater controls.
 3. All power supply wiring for all BAS components.
- B. The Electrical Contractor shall be responsible for the following as they relate to the BAS:
1. The electrical trade shall provide “lock-out stop” control wiring.
 2. A separate system of wiring for smoke and fire control of motors which are to be automatically and/or manually controlled by the fire protective alarm system will be run to the motor starters or BAS enclosures by the electrical trade.
 3. A separate system of wiring for smoke and fire control of dampers that are to be automatically and/or manually controlled directly by the fire protective alarm system (i.e., not in response to motor operation), will be run by the electrical trades except for the power supply wiring to electric damper motors that is specifically excluded from the electrical trade work.
 4. Control devices shall be mounted in panels that contain wiring of 120v or less - control devices shall not be mounted in an enclosure with step down transformers greater than 120v input.

1.4 DEFINITIONS

- A. Algorithm: A logical procedure for solving a recurrent mathematical problem. A prescribed set of well-defined rules or processes for solving a problem in a finite number of steps.
- B. Analog: A continuously varying signal value, such as current, flow, pressure, or temperature.
- C. BACnet Specific Definitions:
 1. BACnet: Building Automation Control Network Protocol, ASHRAE 135. A communications protocol allowing devices to communicate data over and services over a network.
 2. BACnet Interoperability Building Blocks (BIBBs): BIBB defines a small portion of BACnet functionality that is needed to perform a particular task. BIBBs are combined to build the BACnet functional requirements for a device.
 3. BACnet/IP: Defines and allows using a reserved UDP socket to transmit BACnet messages over IP networks. A BACnet/IP network is a collection of one or more IP subnetworks that share the same BACnet network number.

4. BACnet Testing Laboratories (BTL): Organization responsible for testing products for compliance with ASHRAE 135, operated under direction of BACnet International.
 5. PICS (Protocol Implementation Conformance Statement): Written document that identifies the particular options specified by BACnet that are implemented in a device.
- D. Binary: Two-state signal where a high signal level represents ON" or "OPEN" condition and a low signal level represents "OFF" or "CLOSED" condition. "Digital" is sometimes used interchangeably with "Binary" to indicate a two-state signal.
- E. Controller: Generic term for any standalone, microprocessor-based, digital controller residing on a network, used for local or global control. Three types of controllers are indicated: Network Controller, Programmable Application Controller, and Application-Specific Controller.
- F. Control System Integrator: An entity that assists in expansion of existing enterprise system and support of additional operator interfaces to I/O being added to existing enterprise system.
- G. COV: Changes of value.
- H. DDC System Provider: Authorized representative of, and trained by, DDC system manufacturer and responsible for execution of DDC system Work indicated.
- I. Distributed Control: Processing of system data is decentralized and control decisions are made at subsystem level. System operational programs and information are provided to remote subsystems and status is reported back. On loss of communication, subsystems shall be capable of operating in a standalone mode using the last best available data.
- J. DOCSIS: Data-Over Cable Service Interface Specifications.
- K. E/P: Voltage to pneumatic.
- L. Gateway: Bidirectional protocol translator that connects control systems that use different communication protocols.
- M. HLC: Heavy load conditions.
- N. I/O: System through which information is received and transmitted. I/O refers to analog input (AI), binary input (BI), analog output (AO) and binary output (BO). Analog signals are continuous and represent control influences such as flow, level, moisture, pressure, and temperature. Binary signals convert electronic signals to digital pulses (values) and generally represent two-position operating and alarm status. "Digital," (DI and (DO), is sometimes used interchangeably with "Binary," (BI) and (BO), respectively.
- O. I/P: Current to pneumatic.
- P. LAN: Local area network.
- Q. Low Voltage: As defined in NFPA 70 for circuits and equipment operating at less than 50 V or for remote-control, signaling power-limited circuits.

- R. Mobile Device: A data-enabled phone or tablet computer capable of connecting to a cellular data network and running a native control application or accessing a web interface.
 - S. Modbus TCP/IP: An open protocol for exchange of process data.
 - T. MS/TP: Master-slave/token-passing, IEE 8802-3. Datalink protocol LAN option that uses twisted-pair wire for low-speed communication.
 - U. MTBF: Mean time between failures.
 - V. Network Controller: Digital controller, which supports a family of programmable application controllers and application-specific controllers, that communicates on a peer-to-peer network for transmission of global data.
 - W. Network Repeater: Device that receives data packet from one network and rebroadcasts it to another network. No routing information is added to protocol.
 - X. Peer to Peer: Networking architecture that treats all network stations as equal partners.
 - Y. POT: Portable operator's terminal.
 - Z. PUE: Performance usage effectiveness.
 - AA. RAM: Random access memory.
 - BB. RF: Radio frequency.
 - CC. Router: Device connecting two or more networks at network layer.
 - DD. Server: Computer used to maintain system configuration, historical and programming database.
 - EE. TCP/IP: Transport control protocol/Internet protocol.
 - FF. UPS: Uninterruptible power supply.
 - GG. USB: Universal Serial Bus.
 - HH. User Datagram Protocol (UDP): This protocol assumes that the IP is used as the underlying protocol.
 - II. VAV: Variable air volume.
 - JJ. WLED: White light emitting diode.
- 1.5 PREINSTALLATION MEETINGS
- A. Preinstallation Conference: Conduct conference at Project site and work with the UMD PM to invite the CCMS Superintendent.

1.6 DOCUMENTATION GENERAL

- A. The CCMS BAS controls contractor shall comply with the contract submittal requirements for content and quantity. Further, the CCMS BAS controls contractor shall provide O&M documentation in editable digital format.
- B. All Hard copies of O&M documentation to be provided in electronic PDF format and made available to the CCMS Operations Supervisor.
- C. Laminated control drawings printed size shall not be less than 11 x 17.
- D. Laminate BAS drawings of JACE Panels shall detail associated building BAS IP Topology.
- E. All project BAS O&M documentation shall be sent to CCMS Operations Supervisor (301-405-3244).
- F. BAS vendor shall provide a single Point of Contact for all project documentation.

1.7 ACTION SUBMITTALS

- A. Multiple Submissions:
 - 1. If multiple submissions are required to execute work within schedule, first submit a coordinated schedule clearly defining intent of multiple submissions. Include a proposed date of each submission with a detailed description of submittal content to be included in each submission.
 - 2. Clearly identify each submittal requirement indicated and in which submission the information will be provided.
 - 3. Include an updated schedule in each subsequent submission with changes highlighted to easily track the changes made to the previous submitted schedule.
- B. Product Data: For each type of product include the following:
 - 1. Equipment tags, point names, point description for all equipment to be controlled. (Reference see section 3.8, 3.9 & 3.10). Sample graphics with equipment and point naming convention reflected.
 - 2. Points and Alarm List: Submit table of all physical input/output (I/O) points. Indicate all physical and virtual points and organize by system/sub-system. Include names, descriptors, and point types as a minimum. Include the following information:
 - a. Point Type (AI, BI, AO, BO, BV, and AV).
 - b. Specific input points that must be able to be put in test mode to facilitate commissioning
 - c. If point is associated with alarms

- d. If point is trended and initial interval (adjustable)
- e. If point is on BAS Graphic,
- f. Point Address.
3. Construction details, material descriptions, dimensions of individual components and profiles, and finishes.
4. Operating characteristics, electrical characteristics, and furnished accessories indicating process operating range, accuracy over range, control signal over range, default control signal with loss of power, calibration data specific to each unique application, electrical power requirements, and limitations of ambient operating environment, including temperature and humidity.
5. Product description with complete technical data, performance curves, and product specification sheets.
6. Installation, operation and maintenance instructions including factors affecting performance.
7. Bill of materials indicating quantity, manufacturer, and extended model number for each unique product.
 - a. Workstations.
 - b. Servers.
 - c. Routers.
 - d. Protocol analyzers.
 - e. DDC controllers.
 - f. Enclosures.
 - g. Electrical power devices.
 - h. UPS units.
 - i. Accessories.
 - j. Instruments.
 - k. Control dampers and actuators.
 - l. Control valves and actuators.
8. When manufacturer's product datasheets apply to a product series rather than a specific product model, clearly indicate and highlight only applicable information.

9. Each submitted piece of product literature shall clearly cross reference specification and drawings that submittal is to cover.
- C. Shop Drawings:
1. General Requirements:
 - a. Include cover drawing with Project name, location, Owner, Architect, Contractor and issue date with each Shop Drawings submission.
 - b. Include a drawing index sheet listing each drawing number and title that matches information in each title block.
 - c. Drawings Size: 8.5"x11 or 11x17.
- D. Point Description Submittal:
1. The building automation controls contractor shall submit a listing of all automated equipment (AHUs, Pumps, Chillers, Exhaust Fans, VAV's, FCU's) for review by the CCMS group. The intent of the point description approval process is to avoid equipment tagging conflicts in existing buildings where renovation or addition work is performed. The point naming convention is defined below (Reference).
- E. A detailed submittal will be prepared and submitted by the BAS Control Vendor for approval by the design professional and the University of Maryland, CCMS. The submittal and record documents shall include:
1. Control system architecture and communication riser diagram
 2. Control schematic drawings for each system
 3. Points lists for each system, including alarm points
 4. Written sequences for each system: The BAS vendor shall provide detailed written sequences of operation for each system, preferably on a consolidated BAS drawing along with the control schematic and points/alarm list. All related equipment should be grouped together by areas served. Also, group all sequences into functional sections (i.e., start/stop, static pressure control, economizer, etc.). The sequences shall include, as a minimum, the following information.
 - a. Sequences in all modes of operation: on, off, occupied, unoccupied, warm-up, cool-down, night setback, summer, winter, economizer, etc.
 - b. Sequences shall be organized into logical groupings including: run/stop, pressure, economizer, coils, discharge air, humidification, dehumidification, hydronic temperature, etc.
 - c. Detailed steps during mode switches.
 - d. Specific direction on failure scenarios for loss of proof and all safety device trips.

- e. Setpoints, trip points, and ranges.
 - f. Fire/smoke control system interfaces.
 - g. Schedule of operation.
 - h. Fire alarm panel interlocks and special operating modes.
 - i. Sample Graphics and Trends: If the project includes web-based graphics and trends for the use of interfacing to the BAS, the BAS vendor shall submit draft samples of the actual graphics to be used for the project
5. Floor Plans showing equipment locations:
- a. BAS vendor shall provide a set of floor plans with all controllers/control panels, sensors, operator workstations, interface devices, UPS's, etc., located and identified. The BAS vendor shall indicate all network components (routers, etc.); network wiring shall be shown and identified on the floor plan drawings. Include location of status pressure sensors probes in ductwork on floorplan. ALL CONTROL PANELS SHALL BE IDENTIFIED BY AN EXTERIOR TAG, CONSISTENT WITH IDENTIFICATION WITHIN THE ATC O&M MANUAL, SECURED ON THE EXTERIOR UPPER LEFT HAND CORNER.
6. Control System Architecture Diagram:
- a. Provide a system architecture one-line diagram indicating schematic location of all controllers, workstations, LAN interface devices, gateways, etc. The BAS vendor shall indicate address and type for each control unit; as well as indicate physical media, protocol, communication speed, and type of each LAN.
 - b. Do not use gateways to connect to legacy CCMS systems.
7. Wiring Diagrams:
- a. The BAS vendor shall include detailed wiring. Indicate all required electrical wiring. Wiring diagrams shall include both ladder logic type diagrams for motor starter, control, and safety circuits and detailed digital interface panel point termination diagrams with all wire numbers and terminal block numbers identified. Provide panel termination drawings on separate drawings. Ladder diagrams shall appear on the system schematic. Clearly differentiate between portions of wiring that are factory-installed and portions to be field-installed. All wiring of related components that make up a system shall be grouped together in one diagram (e.g., all wiring diagrams for the components and devices on a particular AHU shall be shown on one drawing. The supply fan components and devices should not be shown separate from return fan components and devices, etc.).
8. Device Schedules, including equipment, AHU's, VAV's, pumps, heat exchangers, control valves, modulating dampers, etc.

9. Include details of product assemblies. Indicate dimensions, weights, loads, required clearances, method of field assembly, components, and location and size of each field connection.
10. Detail means of vibration isolation and show attachments to rotating equipment.
11. Plan Drawings indicating the following:
 - a. Screened backgrounds of walls, structural grid lines, HVAC equipment, ductwork and piping.
 - b. Room names and numbers with coordinated placement to avoid interference with control products indicated.
 - c. Each desktop workstation, server, gateway, router, DDC controller, control panel instrument connecting to DDC controller, and damper and valve connecting to DDC controller, if included in Project.
 - d. Exact placement of products in rooms, ducts, and piping to reflect proposed installed conditions.
 - e. Network communication cable and raceway routing.
 - f. Information, drawn to scale, of no smaller than 1/8" per 1'.
 - g. Proposed routing of wiring, cabling, conduit, and tubing, coordinated with building services for review before installation.
12. Schematic drawings for each controlled HVAC system indicating the following:
 - a. Both the design professional and the BAS vendor shall develop detailed control schematics of all systems and zone configurations. The control schematics shall be utilized to graphically indicate the systems, show the schematic configuration of the systems and location of control devices, define the point names and addresses (as applicable), and define the setpoints for control elements. Communication Architecture Riser Diagrams shall incorporate all new and existing controllers, router and switches including panel locations. The following information shall be included in the controls schematics at a minimum:
 - b. BAS legend and abbreviations.
 - c. BAS one-line Architecture diagram.
 - d. Point names and types.
 - e. Normal position of output devices.
 - f. Setpoints.

- g. Point addresses and device ranges (BAS vendor only). See Standard 230901 for requirements.
 - h. Bill of materials listing all devices and manufacturer numbers (BAS vendor only).
13. Control panel drawings indicating the following:
- a. Panel dimensions, materials, size, and location of field cable, raceways, and tubing connections.
 - b. Interior sub panel layout, drawn to scale and showing all internal components, cabling and wiring raceways, nameplates and allocated spare space (spare spaces to meet 10% minimum for each type of point, minimum of 1 type each AI, AO, BI, BO.
 - c. Front, rear, and side elevations and nameplate legend.
 - d. Unique drawing for each panel.
14. DDC system network riser diagram indicating the following:
- a. Each device connected to network with unique identification for each.
 - b. Interconnection of each different network in DDC system.
 - c. For each network, indicate communication protocol, speed and physical means of interconnecting network devices, such as copper cable type, or optical fiber cable type. Indicate raceway type and size for each.
 - d. Each network port for connection of an operator workstation or other type of operator interface with unique identification for each.
15. DDC system electrical power riser diagram indicating the following:
- a. Each point of connection to field power with requirements (volts/phase//hertz/amperes/connection type) listed for each.
 - b. Each control power supply includes, as applicable, transformer locations, and specifications, power-line conditioners, transient voltage suppression and high filter noise units, DC power supplies, and UPS units with unique identification for each.
 - c. Each product requiring power with requirements (volts/phase//hertz/amperes/connection type) listed for each.
 - d. Power wiring type and size, race type, and size for each.
16. Monitoring and control signal diagrams indicating the following:
- a. Control signal cable and wiring between controllers and I/O.

- b. Point-to-point schematic wiring diagrams for each product.
 - c. Control signal tubing to sensors, switches and transmitters.
 - d. Process signal tubing to sensors, switches and transmitters.
 - e. Pneumatic main air and control signal tubing to pneumatic damper and valve actuators, pilot-positioners if applicable, and associated transducers.
17. Color graphics indicating the following:
- a. Itemized list of color graphic displays to be provided.
 - b. For each display screen to be provided, a true color copy showing layout of pictures, graphics and data displayed.
 - c. Intended operator access between related hierarchical display screens.
- F. System Description:
- 1. Full description of DDC system architecture, network configuration, operator interfaces and peripherals, servers, controller types and applications, gateways, routers and other network devices, and power supplies.
 - 2. Complete listing and description of each report, log and trend for format and timing and events which initiate generation.
 - 3. System and product operation under each potential failure condition including, but not limited to, the following:
 - a. Loss of power.
 - b. Loss of network communication signal.
 - c. Loss of controller signals to inputs and outpoints.
 - d. Operator workstation failure.
 - e. Server failure.
 - f. Gateway failure.
 - g. Network failure
 - h. Controller failure.
 - i. Instrument failure.
 - j. Control damper and valve actuator failure.

4. Complete bibliography of documentation and media to be delivered to Owner.
 5. Description of testing plans and procedures.
 6. Description of Owner training.
- G. Delegated-Design Submittal: For DDC system products and installation indicated as being delegated.
1. Supporting documentation showing DDC system design complies with performance requirements indicated, including calculations and other documentation necessary to prove compliance.
 2. Schedule and design calculations for control dampers and actuators.
 - a. Flow at Project design and minimum flow conditions.
 - b. Face velocity at Project design and minimum airflow conditions.
 - c. Pressure drop across damper at Project design and minimum airflow conditions.
 - d. AMCA 500-D damper installation arrangement used to calculate and schedule pressure drop, as applicable to installation.
 - e. Maximum close-off pressure.
 - f. Leakage airflow at maximum system pressure differential (fan close-off pressure).
 - g. Torque required at worst case condition for sizing actuator.
 - h. Actuator selection indicating torque provided.
 - i. Actuator signal to control damper (on, close or modulate).
 - j. Actuator position on loss of power.
 - k. Actuator position on loss of control signal.
 3. Schedule and design calculations for control valves and actuators.
 - a. The BAS vendor shall provide control valve selections and a schedule. Valve sizes shall be picked as close as possible to meet the design pressure drop. The schedule shall include the following:
 - b. Manufacturer and Model Number.
 - c. Valve Size and CV Rating.
 - d. Actuator and Model Number.

- e. Type (2-way/3-way, spring return/non spring return, etc.)
 - f. Flow and pressure drop at design maximum flow.
 - g. Normal positions.
 - h. Close off rating.
 - i. Valve characteristic.
 - j. Valve turndown.
 - k. Design controlled circuit pressure differential range (BAS vendor only, coordinated with the submittals).
4. Damper Schedule: The BAS vendor shall provide damper selections and a schedule. The schedule shall include the following:
- a. Manufacturer and Model Number.
 - b. System Served.
 - c. Damper Size and Leakage Class
 - d. Actuator and Model Number, Pilot (Y/N), Range and Mounting Position
 - e. Size and Type (parallel blade/opposed blade, etc.)
 - f. Design flow and pressure drop
 - g. Normal positions.
 - h. Leakage Class
5. Schedule and design calculations for selecting flow instruments.
- a. Instrument flow range.
 - b. Project design and minimum flow conditions with corresponding accuracy, control signal to transmitter and output signal for remote control.
 - c. Extreme points of extended flow range with corresponding accuracy, control signal to transmitter and output signal for remote control.
 - d. Pressure-differential loss across instrument at Project design flow conditions.
 - e. Where flow sensors are mated with pressure transmitters, provide information for each instrument separately and as an operating pair.

1.8 INFORMATIONAL SUBMITTALS

A. Coordination Drawings:

1. Plan drawings and corresponding product installation details, drawn to scale, on which the following items are shown and coordinated with each other, using input from installers of the items involved:
 - a. Product installation location shown in relationship to room, duct, pipe and equipment.
 - b. Structural members to which products will be attached.
 - c. Wall-mounted instruments located in finished space showing relationship to light switches, fire-alarm devices and other installed devices.
 - d. Size and location of wall access panels for products installed behind walls and requiring access.
2. Reflected ceiling plans and other details, drawn to scale, on which the following items are shown and coordinated with each other, using input from installers of the items involved:
 - a. Ceiling components.
 - b. Size and location of access panels for products installed above inaccessible ceiling assemblies and requiring access.
 - c. Items penetrating finished ceiling including the following:
 - 1) Lighting fixtures.
 - 2) Air outlets and inlets.
 - 3) Speakers.
 - 4) Sprinklers.
 - 5) Access panels.
 - 6) Motion sensors.
 - 7) Pressure sensors.
 - 8) Temperature sensors and other DDC control system instruments.
3. Manufacturer's qualification data.
4. Testing agency's qualifications data.

B. Welding certificates (as applicable).

- C. Field quality-control reports.
- D. Sample Warranty: For manufacturer's warranty.

1.9 CLOSEOUT SUBMITTALS

- A. Operation and Maintenance Data: For DDC system to include in emergency, operation and maintenance manuals.
 - 1. In addition to items specified in Section 017823 "Operation and Maintenance Data," include the following:
 - a. Project Record Drawings of as-built versions of submittal Shop Drawings provided in electronic PDF format for record. In addition, provide the written sequences of operation and system diagrams in an editable format so the UMD CCMS group can update to reflect future system modifications. In addition, final as-built control drawings (in PDF format) shall be accessible via the web based graphics with link on the system screen to the appropriate document.
 - b. Testing and commissioning reports and checklists of completed final versions of reports, checklists, and trend logs.
 - c. As-built versions of submittal Product Data.
 - d. Operator's manual with procedures for operating control systems including logging on and off, handling alarms, producing point reports, trending data, overriding computer control and changing set points and variables.
 - e. The BAS vendor shall provide Operation and Maintenance (O&M) materials prior to the start of training. O&M materials shall include the following maintenance instructions and spare parts list for each type of control device, control unit, and accessory.
 - 1) BAS User's Guides (Operating Manuals) for each controller type and for all workstation hardware and software and workstation peripheral.
 - 2) BAS Programming Manuals for each controller type and for all workstation software.
 - 3) All information provided during the submittal phase; updated with as-built information. As-built panel drawings shall also be included as part of the O&M manual process. The drawings that are located in each panel shall incorporate all the systems controlled from that particular panel. The drawings shall include the system schematic and detailed panel wiring diagram. Also included (typically noted on the system schematic diagrams) should be the specific locations of any remote devices such as remote static pressure sensors, differential pressure sensors, etc.).

- 4) Each control panel on the project shall include an as-built hard copy of all drawings and documentation associated with that panel and its field devices. This documentation shall be provided in a plastic protective pocket mounted or laminated and glued inside the panel door.
- f. Engineering, installation, and maintenance manuals that explain how to:
 - 1) Design and install new points, panels, and other hardware.
 - 2) Perform preventive maintenance and calibration.
 - 3) Debug hardware problems.
 - 4) Repair or replace hardware.
- g. Documentation of all programs created using custom programming language including set points, tuning parameters, and object database.
- h. Complete original-issue documentation, installation, and maintenance information for furnished third-party hardware including computer equipment and sensors.
- i. Laminated as-built wiring diagrams are to be installed in each field controller cabinet. The as-built documents are to be kept current for the duration of the warranty period.
- j. Licenses, guarantees, and warranty documents.
- k. Owner training materials.

1.10 QUALITY ASSURANCE

- A. Testing Agency Qualifications: Member company of NETA.
 1. Testing Agency's Field Supervisor: Certified by NETA to supervise on-site testing.
- B. Welding Qualifications: Qualify procedures and personnel according to the following:
 1. AWS D1.1/D1.1M, "Structural Welding Code - Steel."
 2. AWS D1.2/D1.2M, "Structural Welding Code - Aluminum."
 3. AWS D1.3/D1.3M, "Structural Welding Code - Sheet Steel."
 4. AWS D1.4/D1.4M, "Structural Welding Code - Reinforcing Steel."
- C. Pipe and Pressure-Vessel Welding Qualifications: Qualify procedures and operators according to ASME Boiler and Pressure Vessel Code.

1.11 WARRANTY

- A. **Manufacturer's Warranty:** Manufacturer and Installer agree to repair or replace products that fail in materials or workmanship within specified warranty period.
1. Failures shall be adjusted, repaired, or replaced at no additional cost or reduction in service to Owner.
 2. Include updates or upgrades to software and firmware if necessary to resolve deficiencies.
 - a. Install updates only after receiving Owner's written authorization.
 3. Warranty service shall occur during normal business hours and commence within 24 hours of Owner's warranty service request.
 4. Warranty Period: Two year(s) from date of Substantial Completion.
 - a. For Gateway: Two-year parts and labor warranty for Gateway approved by UMD.

PART 2 - PRODUCTS

2.1 DDC SYSTEM MANUFACTURERS

- A. System Configuration: The University of Maryland currently uses two (2) automation platforms that use fully graphically programmable BACnet controllers. The Acceptable Systems Architecture is as follows:
1. Tridium Niagara with Distech Controllers (TN-D)
 2. Automated Logic Corporation (ALC)
- B. Existing building typically have established Automation platform. Additional or new work (including a new wing of an existing building) shall be an extension of established building automation platform.
- C. Tridium Niagara with Distech Controllers (TN-D) Recommended Contractors
Capron Company, In
411 N Stonestreet Ave
Rockville, MD 20850
Phone: (301) 424-9500
Steve Ferrick - SFerrick@capron.com
- D. Tridium Niagara with Distech Controllers (TN-D) Recommended Contractors
Smart Building Technologies
4800 Hampden Lane, Suite 200
Bethesda, MD 20814
(240) 482-3706
Journey Williams - journeyw@smartbuildingtec.com

- E. Automated Logic Corporation (ALC) Recommended Contractor:
EMS Technologies, LLC
DBA Albireo Energy, LLC
2134 Espey Court, STE 5-9
Crofton MD, 21114
(443) 987-1025
Katie Walter – kawalter@albireoenergy.com

2.2 DDC SYSTEM DESCRIPTION

- A. The Tridium Niagara with Distech controller's platform is an open platform design based on the Tridium JACE (JAVA Application Control Engine) and the Niagara N4 framework. The JACE is a compact, embedded controller/server platform. It combines integrated control, supervision, data logging, alarming, scheduling and network management functions with Internet connectivity and web serving capabilities. Niagara AX framework software applications and tools are designed to integrate a variety of devices and protocols into unified, distributed systems. The Staefa Talon Niagara supports a wide range of protocols including Staefa-Smart II, LonWorks™, BACnet™, Modbus, oBIX, and Internet standards. The CCMS group has adopted the use of Distech controls as the primary application controller using the BACnet protocol under the TN framework. The Distech pre-engineering programming tools provides a fully integrated solution providing full controller programming capability through Niagara AX framework.
- B. The ALC system is an open platform that employs native ALC controllers are used under its Web Control server architecture. The architecture is such that all the ALC campus building databases and graphical user interfaces are routed through a single server. The Web Control system also provides integrated control, supervision, data logging, alarming, scheduling and network management functions with Internet connectivity and web serving capabilities. The ALC Web Control integrates a variety of devices and protocols into unified, distributed systems including BACnet™, Modbus and Internet standards.
- C. Electrical Components, Devices, and Accessories: Listed and labeled as defined in NFPA 70, by a qualified testing agency, and marked for intended location and application.

2.3 WEB ACCESS

- A. DDC system shall be **Web based**
1. Web-Based Access to DDC System:
 - a. DDC system software shall be based on server thin-client architecture, designed around open standards of Web technology. DDC system server shall be accessed using a Web browser over DDC system network, using Owner's LAN, and remotely over Internet through Owner's LAN.
 - b. TN-D Graphical representation shall reside on the N4 main server.
 - c. The primary TN-D graphic displays shall be constructed from Tridium N4 KitPxHVAC library Palette.

- d. Additional graphical elements created by an integrator shall be stored on the N4 server for use by all other integrators.
 - e. Each integrator shall be responsible for maintaining continuity with previously developed representations and associated navigation format.
 - f. Intent of thin-client architecture is to provide operators complete access to DDC system via a Web browser. No special software other than a Web browser shall be required to access graphics, point displays, and trends; to configure trends, points, and controllers; and to edit programming.
 - g. Web access shall be password protected.
2. Web-Compatible Access to DDC System:
- a. Workstation and server shall perform overall system supervision and configuration, graphical user interface, management report generation, and alarm annunciation.
 - b. DDC system shall support Web browser access to building data. Operator using a standard Web browser shall be able to access control graphics and change adjustable set points.
 - c. Web access shall be password protected.

2.4 CONTROLLERS

- A. Building- and system-level controllers shall be capable of operating independently, in stand-alone fashion, with no communication to other devices on the network while performing their monitoring and control routines using programs and operating parameters stored in the controllers' memory. All points and functions that make up a functional system (typically that shown on one control schematic) shall be included in one controller to qualify for this stand-alone functionality
- B. Where control sequences depend on global variables such as outside air temperature, the controller shall have the capability of either using the last value or a default value. The design professional shall specifically indicate point groupings for stand-alone capability. Examples of required functional point groupings are as follows:
 - 1. All points and functions required to control an air handler with all directly associated supply, return, and exhaust fans. This excludes the terminals that may be associated with that air handler. Values that may be received across the network include humidity, emergency power source indication, terminal based reset parameters, and smoke modes. In a lab environment, any 100 % outside supply AHU with associated exhaust fan systems must be hardwired interlocked for safe shut down.
 - a. If the exhaust system fails then supply shall stop through hardwired interlock.
 - b. If supply fan fails the exhaust system shall remain operational

2. All points associated with the supply side of a hydronic system such as pumps, flow meters, temperature and pressure sensors, proof indications, valves etc. This excludes the terminals on that hydronic system. Values that may be received across the network include outside air temperature and humidity, emergency power source indication, and terminal based reset parameters.
 3. All points and functions required to control one terminal system including dampers, valves, flow meters, temperature and humidity sensors, etc. This does not include the scheduling period or any outside air that may be necessary for control.
- C. Controller software must be capable of detecting hardware and software failures and forcing all outputs to a predetermined state, consistent with the failure mode requirements defined on the drawings. Freeze, Fire, Smoke and High/Low Static pressure safeties shall be hardware interlocked to stop associated fans and pump motors. Software safeties shall be the exception, not the rule and require approval.
- D. Controllers must include sufficient memory for all required operations, backups and all required trending. Where control system operation is hindered by the shortage of memory, contractor shall, at no cost to the Owner, either upgrade the memory or provide multiple controllers. The mix of points for multiple controllers shall not violate the stand-alone requirements.
- E. Volatile memory is required to be backed up in the event of power loss. Software stored in non-volatile memory will not have to be downloaded from the central server after an interruption of power occurs
- F. Controllers used for time-scheduled operations must be equipped with a battery backed internal real-time clock function to provide a time base for implementing time-dependent programs. Provision shall be made for the routine updating of the controllers' clocks via a time master
- G. Resumption of power after an outage shall cause the controllers to automatically restart and establish communications as needed by their applications. Controller shutdown based on a self-diagnosed failure in the power supply, hardware, or software must set each piece of controlled equipment to a predetermined failure mode. The equipment shall restart automatically without the need of the operator to acknowledge (i.e. no front end latching).
- H. CCMS Controllers shall be provided with backup power from the source that is connected to any of the systems it serves. In a situation where the controller is connected to equipment that is on emergency power the controller and devices shall be connected to a UPS or be on an emergency circuit with battery backup to ride through the transition to emergency power. In the situation where a controller will be required to continuously collect data to be transmitted to a workstation, or where it monitors critical recovery information such as the presence of emergency power, provide a UPS for the controller as well as any critical sensors. Where panels are provided with a different power source as the equipment (such as when the panel is on a UPS), the panel shall be provided with a means of monitoring the power source to the controlled equipment. This can be a dedicated power monitor or a value coming from transfer switch contacts

2.5 TEMPERATURE SENSORS:

- A. Sensor Resolution: When matched with A/D converter of the controller, sensor range shall provide a resolution of no less than 0.4 °F (unless spec notes otherwise).
- B. Room Temperature Sensor: These shall be an element contained within a ventilated cover, suitable for wall mounting. Provide an insulated base.
 - 1. Sensing element: RTD or thermistor, +/- 0.8 °F accuracy at calibration point.
 - 2. Setpoint Adjustment: Provide where indicated. Public spaces shall not have setpoint adjustment. The setpoint adjustment shall be a warmer/cooler indication that shall be scalable via the BAS.
 - 3. Occupancy Override: Provide a button on the room sensor enclosure where indicated for spaces that do not have occupancy sensors. Public spaces shall not have occupancy override. This shall be a momentary contact closure.
 - 4. Display: Alphanumeric.
 - 5. Sensors shall be provided with communication jack and appropriate cabling for connection to the BAS.
 - 6. All Room Wall Mount temperature sensors shall include Occupancy Motion Sensors.
- C. Single Point Duct Temperature Sensor: These shall consist of a sensing element, junction box for wiring connections, and a gasket to prevent air leakage or vibration noise. The sensor probe shall be stainless steel.
 - 1. Sensing element: RTD or thermistor, +/- 0.5 °F accuracy at calibration point.
- D. Averaging Duct Temperature Sensor: These shall consist of an averaging element, junction box for wiring connections, and gasket to prevent air leakage. Provide sensor lengths and quantities to result in one foot of sensing element for each, two square feet of coil/duct face area.
 - 1. Sensing element: RTD or thermistor, +/- 0.5 °F accuracy at calibration point.
- E. Liquid Immersion Temperature Sensor: These shall include brass or stainless steel thermos well, sensor and connection head for wiring connections.
 - 1. Sensing element: RTD, thermistor, or integrated circuit, +/- 0.4 °F accuracy at calibration point.
 - 2. Temperature Range: As required for resolution of 0.3 °F.
- F. Outside Air Temperature Sensor: These shall consist of a sensor, sun shield, utility box, and watertight gasket to prevent water seepage. On major/critical systems, one outside air temperature sensor shall be provided for each system; and one sensor shall be provided per mechanical room, or building-level controller. Generally, these shall be located on a north wall of the building and installed with stand-offs. On 100% outside air systems, locate the sensor in the outside air plenum.

1. Sensing element: RTD, thermistor, 0-10v, or integrated circuit, +/- 0.4 °F accuracy at calibration point. UMD standard uses 10k Type II for ALC and 10k Type III for Distech

2.6 HUMIDITY SENSORS

- A. Units shall be suitable for duct, wall (room), or outdoor mounting. Sensors shall be two-wire transmitters utilizing bulk polymer resistance change or thin film capacitance change. Units shall produce linear continuous output of 0-10v for % RH. Sensors shall have the following minimum performance and application criteria:

1. Input Range: 0 to 100% RH.
2. Accuracy (% RH): +/- 2% (when used for enthalpy calculation, dewpoint calculation, or humidifier control); or +/- 3% (when used for monitoring) between 20-90% RH at 77 °F, including hysteresis, linearity, and repeatability.
3. Operating Range: As required by the application.
4. Long Term Stability: Less than 1% drift per year.

- B. Acceptable Manufacturers:

1. Vaisala
2. Veris Industries
3. For laboratories combination temperature/humidity sensor provided by the controls contractor may be should be selected in coordination with laboratory customer and approved by UMD PM.
4. For wall mounted sensor located in Non-Laboratory shall be by primary controller manufacture (ALC or Distech).

2.7 DEWPOINT SENSORS

- A. Typically Dewpoint on UMD projects is calculated from temperature and humidity readings. Where specified, units shall be suitable for duct, wall (room) or outdoor mounting with digital display. Sensors shall be two-wire transmitters utilizing bulk polymer resistance change or thin film capacitance change. Units shall produce linear continuous output of 4-20 mA for dew point temperature (°F) (0-10 VDC may be used for signal transmission less than 100 feet). Sensors shall have the following minimum performance and application criteria.

1. Accuracy: +/- 1.8 °F
2. Sensor Operating Range: As required by the application.
3. Long Term Stability: Less than 1% drift per year.

- B. Acceptable Manufacturers:
 - 1. Vaisala only for lab or cleanroom applications.

2.8 AIR DIFFERENTIAL PRESSURE SENSORS

- A. Supply or exhaust duct mounted static pressure transmitters shall include an LCD display, tagged, and shall be mounted within the associated control panel.
- B. The device shall be configurable for multi-range, voltage signal transmitters.
- C. Duct static pressure probe shall be installed approximately 2/3 of the way down the air duct main trunk, include the location of the duct static pressure probe on the CCMS graphics.
- D. Pressure probe sensing locations shall be identified on automation control floor drawings and included in graphical user interface flow diagram representation.
- E. Pressure probe sensing locations shall be identified on automation control floor drawings and included in graphical user interface representation.
- F. Isolation power supplies shall be required whenever two or more transmitters are associated with the same controller and shall be mounted within the associated control panel.
- G. Basis of Design: Veris PX series.

2.9 LIQUID DIFFERENTIAL PRESSURE SENSOR

- A. Pressure transducers shall be either diaphragm or strain gauge types. Pressure transmitters shall gauge pressure in the form of a linear 4 to 20 mA signal (0-10 VDC may be used for signal transmission less than 100 feet). Sensor shall be installed with a valve manifold and pressure/temperature test ports in lieu of pressure gauges. DP transmitter shall be rated for 150 PSIG static pressure. Wetted parts shall be stainless steel with a silicone fluid-filled diaphragm. Provide external span and zero adjustments
- B. Span shall be no greater than 2 times the working differential pressure of the system to allow the highest possible resolution.
- C. Accuracy : 1% accuracy over the entire span.
- D. Repeatability: Plus or minus 0.5% at maximum span.
- E. Transmitters shall have a three-valve manifold for venting, draining, and calibration.
- F. Wet Pressure Transmitters:
 - 1. Wet pressure transmitters shall include an LCD display and shall be mounted, tagged and LCD display shall be visually accessible without the use of a ladder

2. The device shall be configurable for milliamp or voltage signal, 3 or 4 wire transmitters
3. Pressure probe sensing locations shall be identified on automation control floor drawings and included in graphical user interface flow diagram representation
4. Device installation location shall be accessible from common area (in ceiling above a door to prevent future obstructions) or mechanical room (at eye level).
5. Isolation power supplies shall be required whenever two or more transmitters are associated with the same controller
6. At minimum 3-port Manifold required or Veris PWRLX03S010 with 10-20ft cables
7. Burst Pressure must be 100 psi or greater
8. Basis of Design: Veris PW Series.

2.10 AIR DIFFERENTIAL PRESSURE SWITCHES:

- A. The switches shall be installed in accordance with the manufacturer's installation instructions. All switches shall be mounted in accessible and, to the extent possible, vibration-free locations (i.e., not on duct work).
- B. Basis of Design: Cleveland Controls

2.11 LIQUID DIFFERENTIAL PRESSURE SWITCHES:

- A. Whenever pressure sensing is required to determine status, all switches shall be mounted in accessible and, to the extent possible, vibration-free locations
- B. Do not use differential pressure switches for run status on pumps. Current switches shall be used on constant volume pumps and drive contacts shall be used for pumps with VFDs
- C. Basis of Design: Products by Penn, Setra and Dwyer

2.12 WATER FLOW SENSORS

- A. Flow sensors shall be carefully placed to ensure flow profiles that are required for accurate flow sensing. Designs shall specifically indicate the location of the sensors and indicate the length of unobstructed duct or pipe upstream and downstream from the sensor
- B. Water flow sensors shall meet the requirements necessary for use for test and balance duty as defined in the BAS specifications

2.13 AIRFLOW SENSORS

- A. Flow Sensors shall be carefully placed to ensure flow profiles that are required for accurate flow sensing. Designs shall specifically indicate the location of the sensors and indicate the length of unobstructed duct or pipe upstream and downstream from the sensor.
- B. Laboratory Air Terminal Flow Tracking: The standard manufacturer transducer typically supplied with conventional air terminals are not acceptable for use in a wet laboratory application requiring devices with a higher speed of response. The transducer shall be upgraded to a device with the following specifications.
 - 1. Accuracy : +/- 0.25%.
 - 2. Stability : +/- 0.5% of full scale per year or less
 - 3. Auto-zero capability by venting ports to atmosphere

2.14 AIR HANDLING UNIT AND DUCT AIRFLOW MONITORING:

- A. When identified on the mechanical drawing, all AFMS' shall be thermal dispersion type by Ebtron Gold Series with LCD displays.
- B. AFMS based on Pitot tube sensing are not acceptable.
- C. LCD display shall be visually accessible without the use of a ladder.
- D. Air Flow volume shall be hardwired to associated controller.
- E. Use of BACnet not required.

2.15 AIR HANDLING UNIT MIXING BOX FAN TRACKING:

- A. For Air handling units utilizing building return air and a mixing box
- B. Return Fan VFD Speed Control shall be programmed as indicated. Provide pressure transducers to provide the measurements indicated below (Basis of Design Setra Model 267/267A)..
- C. The Return Fan VFD speed shall linearly track the supply fan speed signal minus (-) Offset (0%, adjustable), where the Offset shall be determined based on the Mixed Box differential pressure as described below.
- D. The MIXED BOX DIFFERENTIAL PRESSURE STATIC PRESSURE shall be used to bias the Return Fan VFD speed linear tracking using a forward acting Proportional-Integral (PI) control loop as required to maintain the MIXED BOX DIFFERENTIAL PRESSURE SET POINT (0.15 Iwc) where the loop result (0-100%) shall bias the fan tracking offset ((-10– (+10)) Speed %, adj.).

- E. The MIXED BOX DIFFERENTIAL PRESSURE control loop shall be 10 times slower than the SUPPLY AIR STATIC PRESSURE control loop to minimize instability.

2.16 CURRENT SENSORS

- A. Application: Status indication on constant speed motors
- B. Sensor shall indicate loss of status when current falls below an adjustable trip point.
- C. CS shall include LED indication of status
- D. Preferred Manufacturer: Veris Industries, Functional Devices

2.17 CURRENT TRANSDUCER

- A. Application: Status indication on constant speed or variable speed motors
- B. Provide split core type.
- C. Preferred Manufacturer: Veris Industries, Functional Devices

2.18 CO2 SENSORS

- A. Application: Demand controlled ventilation of high density occupancy spaces, such as auditoriums, classrooms, lecture rooms, and conference rooms
- B. Range : 0-200 ppm, Accuracy: 2%
- C. Sensor Technology: Solid-state Metal Oxide Semiconductor
- D. Include integral or remote LCD Display so that reading can be observed without use of ladder
- E. Preferred Manufacturer:
 - 1. Vaisala
 - 2. Veris with Display

2.19 OCCUPANCY SENSORS

- A. Wall Occupancy sensors used in classrooms, labs, lecture halls, offices and comparable spaces may use passive infrared occupancy sensors
- B. Ceiling Occupancy sensors used in classrooms, lecture halls, offices and comparable spaces may use dual technology passive infrared and ultra-sonic occupancy sensors

- C. Ceiling Occupancy sensors used in lab environments requires engineer of record get specific project approval for use of dual technology passive infrared and ultra-sonic occupancy sensors
- D. Preferred Manufacturer: Veris MSCD2000 employ passive infrared (PIR) and ultrasonic technologies
- E. Install no less than two occupancy sensors per space in laboratory spaces
- F. Occupancy sensors shall be installed such that the sensor has unobstructed coverage of the entire space

2.20 CONTROL VALVES

- A. General: Valves shall be applicable for the rated pressure and temperature service. Close off pressures must be determined in concert with the actuators and valves shall be provided to close off against extreme anticipated conditions (i.e. AHU's located in same Mechanical Room as Pumps).. Valves selection shall not be based on the CV of design flow and not be oversized.
- B. Modulating valves shall be carefully selected to control in a smooth and stable fashion across the range of anticipated conditions. "Split ranging" of heating and cooling valves controlled by the BAS is not acceptable. A separate output from the BAS shall be provided for all control valves. General guidelines are indicated below. When the selection criteria indicated below are not met, flow characteristic analyses shall be submitted to demonstrate reasonable correlation between stroke and flow. Valves with a CV greater than 30 may be pneumatically actuated, but should only be used if a cost benefit analysis shows they are preferred. Actuator positioning requirements are as follows for each type, if used:
 - 1. Electric Input: 0-10 VDC.
 - 2. Pneumatic Input: 3-15 PSIG (only where Required to Match Existing).
 - 3. Electrically piloted valves shall have a pneumatic actuator with positioner.
 - 4. Pilot positioners shall be required as necessary to keep the valve closed under the maximum differential pressure.
- C. Pressure independent control valves shall be provided to replace existing 3-way control valves to two-way pressure independent control valves where balancing of the valves and associated branch piping shall not be required. Requirements shall be as follows:
 - 1. Absolute flow accuracy; +/- 5% due to system pressure fluctuations across the valve in the selected operating range; +/- 5% due to manufacturing tolerances.
 - 2. The control signal shall be modulating.
 - 3. The valves shall accurately control the flow from 0% to 100% of full rated flow.
 - 4. A minimum of 2 PSI shall be required to operate the valve pressure independently.

5. Close off pressure of 80 PSI for valves located in mechanical rooms with pump equipment.
6. The valves shall require no maintenance and shall not include replaceable cartridges.
7. The valves shall be available with optional pressure/temperature ports to allow for flow verification.
8. Valve pack shall not be provided, the installation of PICV's at terminal units shall have metal to metal unions.

D. Steam Control Valves:

1. Steam control valves shall be rated for the highest system pressure and temperature and shall not lift when subjected to that pressure with the control system set to "fully closed."
2. Steam control valves to be installed on a 45 degree angle with the stem up.
3. All steam control valves shall be electrically actuated and have a flanged or screw body with a rating of 400°F or higher, as appropriate. Trim shall be rated for 400°F.
4. Use high performance segmented V-ball control valves for all steam control applications. These valves are extremely cost-effective; the energy savings associated with the reduced pass-through leakage often pays for the higher cost premium. In addition, these valves require less packing maintenance and use much less vertical space than comparable valves. Steam valves shall have the following characteristics:
 - a. Leakage Class: ANSI Class IV, Minimum
 - b. Flow Characteristic: Equal Percentage
 - c. Rangeability: 300:1 turndown
5. On steam control valves with a normal differential pressure of 15 PSIG or greater, stainless steel noise reducing trim shall be used.
6. Acceptable Manufacturers:
 - a. Siemens
 - b. Belimo
 - c. Warren
7. Fail Positions shall be as follows unless otherwise noted on EOR's control sequence:
 - a. Heat Exchangers/Converters: Normally closed spring return (to protect for high temperature).
 - b. Clean Steam: Normally closed spring return

c. Humidifiers: Normally closed spring return

E. Chilled Water Recirculating Loop Valve (two-way)

1. Type: Rotary-segmented ball ported industrial control valve.
2. Body: Flanged carbon steel.
3. Seat: Composition or stainless/Teflon.
4. Leakage Class: ANSI Class IV, Minimum
5. Trim: 316 Stainless
6. Actuator: Electric
7. Flow Characteristic: Equal Percentage or modified equal.
8. Fail Position: Normally Open spring return.
9. Typical CV shall be selected to give a 2 PSIG drop @ maximum building flow with the valve at the 90% open CV. Verify the necessary pressure drop with CCMS. For buildings located at extremities, check with Engineering Services since requirements may not be typical.
10. Valve shall seat against 40 PSI differential pressure (typical values; check with Engineering Services for location-specific values).
11. Acceptable Manufacturers:
 - a. Siemens
 - b. Belimo
 - c. Bray

F. Coil Valves, Water

1. Modulating water valves will be Pressure Independent ball valves with an equal percentage characteristic. Modulating water valves shall typically be sized for 50-100% of the typical controlled circuit pressure drop at 70% wide open CV. The minimum design CV shall be no less than 1.9.
2. Two position isolation valves shall be butterfly type.
3. Water and Glycol control valves shall be rated to remain closed (zero leakage) against 120% of the full shutoff head of the pumps, when the control signal is set to "fully closed".
 - a. Type : Two-way, V-port ball valve with characterizing disk, 1/4 turn.

- b. Packing: EPDM O-rings, lubricated.
- c. Ball & Stem : Stainless steel.
- d. Seat: Fiberglass reinforced Teflon.
- e. Actuator: Electric, one motor only; valves 4 inches and larger shall have a single operator.
- f. Flow Characteristic: Equal Percentage.
- g. Fail Positions shall generally be as follows (unless otherwise indicated on EOR control sequence) Review with UMD CCMS for special circumstances requiring deviation from these requirements during Submittal development:
 - 1) Terminal Hot Water Radiation: Fail Last.
 - 2) Duct mounted re-heat coils serving animal rooms: normally closed spring return.
 - 3) Duct mounted re-heat coils serving laboratories: fail last.
 - 4) Duct mounted re-heat coils serving offices: fail last.
 - 5) Fan Coil Unit cooling coils: normally closed spring return.
 - 6) Pre-Heat coils in Air Handling Units: normally open spring return.
 - 7) Chilled water coils in Air Handling Units: normally closed spring return.
 - 8) Chilled Beam terminal cooling: normally closed spring return.
 - 9) Lab and non-lab terminal unit control water valves shall fail in place.
- h. Acceptable Manufactures
 - 1) Belimo
 - 2) Siemens
 - 3) Flow Control Delta P (Valves over 2.5" Diameter)

2.21 CONTROL DAMPERS

- A. Dampers shall be applicable for the rated pressure and velocity service. Damper structural rating shall exceed extreme anticipated conditions like fan deadhead.
- B. Modulating dampers shall be carefully selected to control in a smooth and stable fashion across the range of anticipated conditions. Except where size dictates a single blade, dampers shall

always be opposed blade. When a large section of damper is to be connected to a single jackshaft, size limitations shall be followed. This will prevent excessive damper area or, more importantly, length from being connected to a single jackshaft. Typically, the manufacturer's recommendation shall be sufficient for specifying a limit to the size of a damper bank that may have field fabricated jackshaft connections.

- C. Modulating damper position input status shall indicate 0% for fully closed and 100% for full open regardless of Normally Open/Closed definition.
- D. Similarly, damper 0% output command shall fully closed and 100% shall fully open damper regardless of Normally Open/Closed definition.
- E. Whenever possible, dampers shall have external crankshafts to allow the connection of the damper actuator outside of the air stream. This will allow for easier access to the actuators for maintenance.
- F. Outside air control dampers shall be low leakage dampers with damper seals.
- G. Output to modulating control dampers shall be analog.
- H. Specified UL555s Smoke dampers shall be purchased and installed with a factory installed electric actuator.
- I. Acceptable Manufacturers:
 - 1. Ruskin
 - 2. Greenheck
 - 3. Nailor

2.22 ACTUATORS

- A. General: Size actuators and linkages to operate their appropriate dampers or valves with sufficient reserve torque or force to provide smooth modulating action or two-position action and adequate close off rating as required.
- B. For AHU/Duct mounted dampers
 - 1. Actuators Shall Be Electronic.
 - a. Control: Electronic actuators shall be modulated directly by 0-10 VDC control signal.
 - b. Power: Supply power shall be 24 VAC or 120 VAC for high torque applications
 - c. Torque: Minimum torque required X 1.5 rating of actuated device. Actuators to have spring fail safe return capacity where require

- d. Actuators, at minimum required NEMA 4 housing, if installed in exposed outside air or other potentially damaging environmental conditions
 - e. Installer shall mark damper shafts, permanently etched, indicating blade closed position.
 - f. Damper Control: Electronic actuators shall be modulated directly by 0-10 VDC control signal.
2. Standard Electronic Actuators: Shall be designed for a minimum of 60,000 full cycles at full torque and be UL 873 listed. Provide a stroke indicator. Actuators shall have a positive positioning circuit and selectable inputs. Full stroke shall be within 90 seconds. Where fail positions are required, provide spring return on the actuator with adequate close off force.
 3. For AHU's with Mixed Air the Return, Relief and Outside damper shall have individual dedicated damper motors with dedicated AI's and AO's for each motor so that each damper can be commanded / overridden individually if required.
 4. Acceptable Manufacturers:
 - a. Belimo
 - b. Siemens
 - c. Honeywell

2.23 LABORATORY AIRFLOW CONTROL DEVICES

A. Airflow for Fume Hood

1. Provide Venturi Type Air Valves with fast acting electronic actuators on fume hoods and their associated tracking supply and general exhaust zone dampers. In some instances, Vortex Shedding Type Air Valves will be accepted; contact Cornell for project specifics.
2. Venturi Type Air Valves shall have pressure independent operation over a 0.6" to 3.0" drop across the valve; shall respond and maintain a specific airflow within three seconds of a change in duct static pressure.
3. Valves shall be constructed of 16 gauge aluminum; fume hood, canopy, snorkel and biosafety cabinet exhaust assemblies shall have two baked-on coats of a corrosion resistant phenolic coating (Heresite P403 or Phenoflex 957).
4. Actuators shall have a factory mounted and calibrated electronic positioner with position feedback and pressure switch to verify flow. The actuator shall move full stroke in less than one second. Output to modulating actuators shall be analog
5. Acceptable Manufacturers:
 - a. Venturi Type :Phoenix Controls Corporation.

- b. Vortex Shedding Type (Tek-Air).
6. Airflow Flow for Non-Fume Hood Laboratory Applications.
 - a. The Use of Venturi Type or Conventional Type VAV Boxes are both acceptable.
7. Fume Hood Monitors/Controllers: All fume hoods shall be fitted with a fume hood monitor/controller. The monitor/controller shall include indication of safe airflow, re-settable audible and visual alarms when face velocity is out of range, and an emergency ventilation switch or button. Monitor shall also be capable of receiving inputs from the BAS to permit change of the hood face velocity setpoints for occupied/unoccupied/vacancy control strategy.
8. Sash Position Indicators: All fume hoods shall be fitted with a sash position indicator
9. Fail Positions shall be as follows:
 - a. Fume Hood Exhaust: Normally Open.
 - b. Supply Air: Normally Closed.
 - c. General Exhaust: Normally Closed.

2.24 CONTROL PANELS

A. Enclosures:

1. All BAS panels shall be metal enclosures containing the controller, I/O modules, power supplies, fused disconnect, termination strips, battery (if not integral to the controller or I/O module) and a (spare AC120v outlet for LGR or JACE Router/controller.
2. All penetrations of the BAS or outboard gear panels in mechanical rooms shall be from the bottom of the enclosure with wire way and conduit stubs from the wire way up to the panel.
3. All transformers and power supplies shall be mounted outside of the central panel.
4. Interior mechanical room enclosures shall be NEMA-12, steel, painted gray and finished to control oxidation.
5. Enclosures located on exterior areas or interior mechanical areas where heating or steam systems are located shall be NEMA 4 with integral heating and cooling capacity. All NEMA 4 panels shall include:
 - a. Thermostatically controlled fan and drip and insect screen protected vents.
 - b. Internal panel temperature monitored by BAS.
 - c. Penetrations sealed with mechanical bushing or knockout filler, protected with water sealing compound.

6. Enclosures located in labs and other relatively dust free and dry spaces may be NEMA 1.
7. Enclosures shall be mounted on walls or free-standing supports.
8. Provide enclosures with key lockable doors. (For LGR or JACE router network panels or LAB based controller panels).
9. All controllers shall be mounted directly onto panel backplane. Stacking controllers is unacceptable.
10. Laminated control drawings, including the associated panel wiring diagram, control flow and Sequence of Operations, shall be mounted on the inside of the panel door. Laminated control drawings shall not be rescaled small then original.

B. Power Supplies

1. The Contractor shall provide a regulated, protected power supply as required with the ability to produce at least 33% more current than required by the transmitters and controls being installed. Output regulation shall be less than 0.5mV. There shall be no overshoot on turn on or off. Operating temperature shall be -20 to +70°C.
2. The BAS Contractor shall certify, in writing, at the time of shop drawing submittal that the DDC equipment provided will not cause, as a result of its operation, either directly or indirectly, electrical interference to be induced into the building's electrical power systems.
3. Class II transformers shall be used.

2.25 COMPRESSED AIR SYSTEMS

A. General: Where compressed air systems are used, they should meet the following requirements:

1. Compressors shall be reciprocating type.
2. The control system air compressor must be oil lubricated. Compressors shall have built in, high efficiency oil separators. The maximum oil carryover shall be one PPM at rated pressure.
3. The accumulator shall have a manual drain.
4. A coalescing type filter, rated for the full compressor output during system startup (low pressure), shall be installed immediately downstream of the accumulator. The filter shall be equipped with an automatic blow-down.
5. After the accumulator, a hydrocarbon-absorbing filter that changes color as it absorbs oil shall be installed. This filter shall have replaceable cartridges. Systems five horsepower and above shall be equipped with a differential pressure sensing filter.

6. Use duplex air compressors sized for less than one third duty cycle. Size the storage tank to prohibit more than six starts an hour on any compressor. The storage tank shall be equipped with a timed blow-down.
7. The instrumentation air supply must have an air dryer. A refrigerated dryer will typically suffice. However, when continuous air consumption is required on a device or through a pipe that is exposed to unheated condition (especially high pressure air), a desiccant drier shall be provided. Locate all refrigerated dryers in spaces where the ambient air is less than 100°F.
8. Desiccant dryers shall be the heatless type, utilizing a twin tower design and skid mounted. The compressor shall be sized to include the blow down load from heatless desiccant dryers, if used. Regeneration shall be automatic. Dryers over 200 SCFM shall have an energy saving design that controls the regeneration blow-down on the total airflow through the unit. The regeneration blow-down shall be muffled. The dryer shall include mechanical pre-filters and after-filters. The dryer shall be sized for 25% over the instantaneous peak building load. The desiccant dryer shall be equipped with the following accessories:
 - a. Pressure gauges for each tower;
 - b. Tower in-service indicators;
 - c. Output humidity sensor;
 - d. Airflow indicator;
 - e. Power on lamps.
9. Air filters must be installed with bypass and isolation valves to permit filter replacement without instrument air supply disruption.
10. A pressure sensor must be installed and monitored by the BAS for the main supply airline. BAS shall enunciate an alarm any time air pressure falls below the critical point
11. Air Drying and filtration at buildings must be provided when only plant air is being used. Compressed air shall be distributed at high pressure with zoned pressure reducing stations.

2.26 CONTROL TUBING

A. General Requirements

1. All copper tubing in mechanical equipment rooms shall be hard-drawn type L copper or type FR polyethylene installed in conduit.
2. All tubing installed above accessible lift-out ceilings shall be type FR self-extinguishing polyethylene or hard-drawn or soft type L copper.

3. All control tubing installed in vertical chases shall be hard copper. Drip legs on vertical risers and shutoff valves shall be located in an accessible location where main leaves the riser.
4. All control tubing installed in non-accessible walls or ceilings shall be hard-drawn or soft copper or twin tube jacketed polyethylene.
5. All control tubing installed outside shall be jacketed hard copper for single lines and sheathed polyethylene for multiple lines. All lines outdoors shall be supplied via a desiccant dryer.
6. All tubing in control panels shall be type FR polyethylene.
7. All control air hangers shall be clamp type and shall not be attached to other trades.
8. All airlines shall be installed in straight lines in harmony with building construction. No control lines shall be run exposed in occupied spaces. All tubing shall be rigidly supported and protected from vibration. All paths through penetrations shall utilize grommets/sleeves. Label all lines at ends and along route.
9. Isolation Valves Installation:
 - a. Install valves full size of piping and tubing.
 - b. Install at the following locations:
 - 1) At each branch.
 - 2) Before and after each PRV.
 - 3) Before and after each air dryer.
 - 4) At each control device.
 - c. Valves shall be located to be readily accessible from floor.

2.27 CONTROL WIRING

A. General Requirements:

1. Unless specifically required otherwise by the BAS equipment manufacturer, all I/O wiring shall be twisted shielded cable. For communications, the BAS equipment manufacturer's installation guidelines and recommendations shall apply.
2. All control wiring in mechanical equipment rooms or other spaces in which it is readily accessible shall be installed in electrical metal tubing (EMT) with compression fittings. Conduit and junction boxes (along with cover plates) shall be green.

3. All control wiring run in interstitial spaces shall either be run in EMT or a cable tray or raceway.
4. All control wiring installed outdoors or any area subject to moisture shall be installed per code.
5. All control wiring installed in vertical chases shall be installed in EMT.
6. All control wiring above non-accessible ceilings shall be installed in EMT.
7. All control wiring installed above accessible ceiling spaces which are not laboratories or AHU's shall be plenum type, not installed in conduit, but neatly run with generous use of rings or ties.
8. Wire shall be un-spliced from the controller to the sensor or device.
9. Control wiring shall not be routed in the same raceway as power wiring.
10. For sensors with twisted shielded pair cable, the shield shall be grounded at the panel and taped back at the sensor.
11. Control wiring shall be color coded and labeled at all points of termination Per CCMS DCFS 25.13.00.
12. Remove and properly dispose of all abandoned control wiring, conduit, tubing, boxes, enclosures, components, and other controls-related work.
13. All stranded wire is used for screw type connections then spade connectors shall be required to complete termination. (Solderless crimp terminals).

2.28 IP / MSTP DEVICES

- A. A single IP is dedicated to the building. Buildings with multiple JACE's will require an Ethernet IP Router.
 1. Basis of Design: Contemporary Control Model: EIPR-E
- B. All IP secondary devices on a JACE shall communicate on the secondary IP port.
 1. All devices on a network shall be of the same manufacturer.
 2. No Repeaters allowed on the network.
 3. No more than 30 devices on a single port of the router or switch.
- C. All MSTP secondary devices on a JACE shall communicate on the secondary IP port.
 1. All devices on a network shall be of the same manufacturer.

2. No Repeaters allowed on the network.
 3. No more than 30 devices on the network.
- D. A Bacnet IP to MS/TP router shall be used to improve JACE CPU resource usage by offloading the task of MS/TP token passing
1. Basis of Design: Bacnet-Model BASRTLX-B ; Modbus-Model BASGLX-M1.

2.29 PERFORMANCE REQUIREMENTS

- A. Delegated Design: Engage a qualified professional engineer, as defined in Section 014000 "Quality Requirements," to design DDC system to satisfy requirements indicated.
- B. Delegated Design: Engage a qualified professional to design DDC system to satisfy requirements indicated.
1. System Performance Objectives:
 - a. DDC system shall manage HVAC systems.
 - b. DDC system control shall operate HVAC systems to achieve optimum operating costs while using least possible energy and maintaining specified performance.
 - c. DDC system shall respond to power failures, HVAC equipment failures, and adverse and emergency conditions encountered through connected I/O points.
 - d. DDC system shall operate while unattended by an operator and through operator interaction.
 - e. DDC system shall record trends and transactions of events and produce report information such as performance, energy, occupancies, and equipment operation.
- C. Surface-Burning Characteristics: Products installed in ducts, equipment, and return-air paths shall comply with ASTM E84; testing by a qualified testing agency. Identify products with appropriate markings of applicable testing agencies.
1. Flame-Spread Index: 25 or less.
 2. Smoke-Developed Index: 50 or less.
- D. Electric Power Quality:
1. Ground Fault: Protect products from ground fault by providing suitable grounding. Products shall not fail due to ground fault condition.
- E. Backup Power Source:

1. HVAC systems and equipment served by a backup power source shall have associated DDC system products that control such systems and equipment also served from a backup power source.

F. UPS:

1. DDC system products powered by UPS units shall include the following:
 - a. Servers.
 - b. Gateways.
 - c. DDC controllers.
 - d. UPS to be monitored via Bacnet
 - e. UPS unit shall have a dedicated cabinet and not be installed in control panel.
2. DDC system instruments and actuators powered by UPS units shall be identified on the control diagrams.

G. Continuity of Operation after Electric Power Interruption:

1. Equipment and associated factory-installed controls, field-installed controls, electrical equipment, and power supply connected to building normal and backup power systems shall automatically return equipment and associated controls to operating state occurring immediately before loss of normal power, without need for manual intervention by operator when power is restored either through backup power source or through normal power if restored before backup power is brought online.

2.30 SYSTEM ARCHITECTURE

A. System architecture shall consist of no more than three levels of LANs.

1. Level one LAN shall connect network controllers (JACE or LGR) or routers, to the campus server across campus WAN.
2. Level two LAN shall connect application-specific controllers to the network controllers secondary ports. All application controllers need to be behind the Level one equipment.
3. Level three LAN shall connect local application I/O modules to application specific controllers. Remote I/O modules are not allowed.

B. DDC system shall consist of dedicated and separated LANs that are not shared with other building systems and tenant data and communication networks.

C. System architecture shall be modular and have inherent ability to expand to not less than two times system size indicated with no impact to performance indicated.

- D. System architecture shall perform modifications without having to remove and replace existing network equipment.
- E. Number of LANs and associated communication shall be transparent to operator. All I/O points residing on any LAN shall be capable of global sharing between all system LANs.
- F. System design shall eliminate dependence on any single device for system alarm reporting and control execution. Each controller shall operate independently by performing its' own control, alarm management and historical data collection.

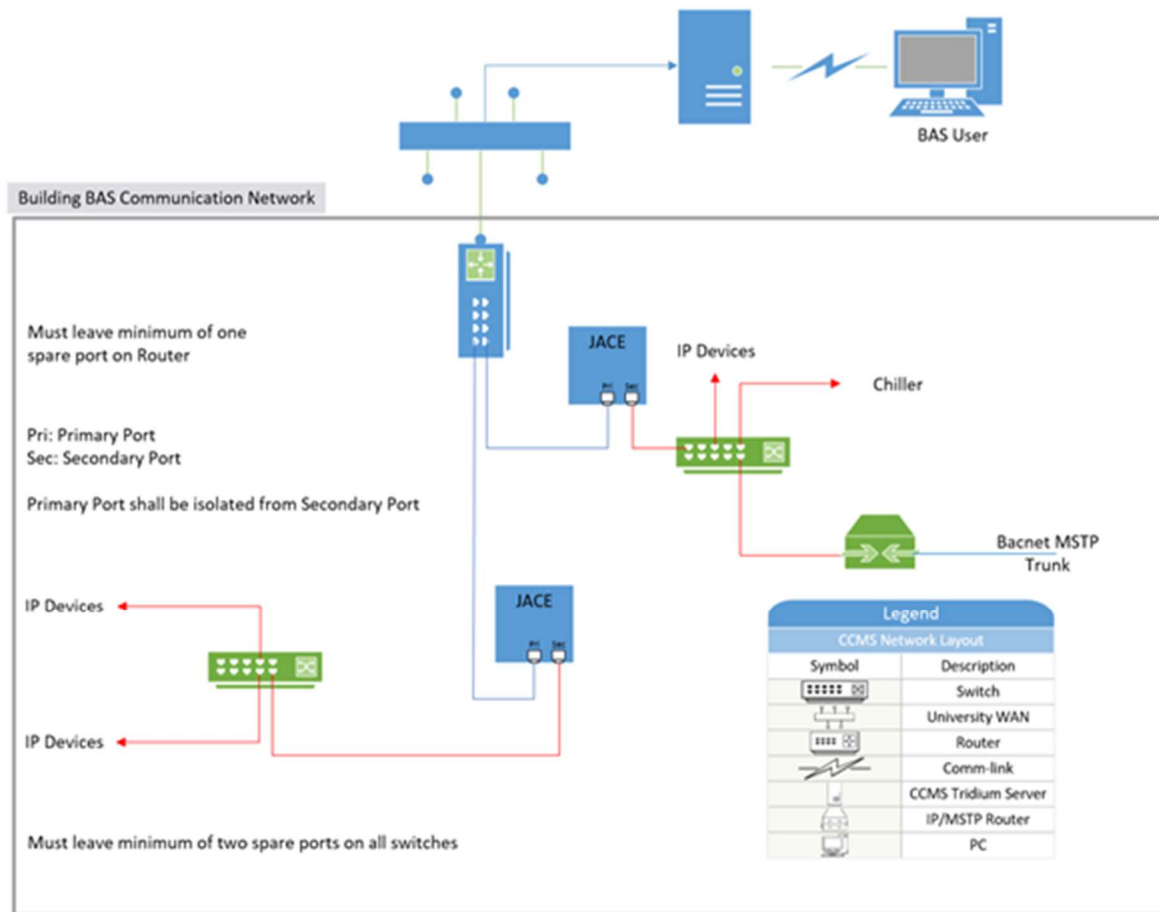

G. IP Controllers

1. A single static IP shall be dedicated to the buildings BAS. Buildings with multiple JACE's will require an Ethernet IP Router.
2. : Contemporary Control Model: EIPR-E or approved equal
3. All controllers, 3rd party devices and meters shall be secondary devices on a JACE shall communicate on the secondary IP network ports.

4. A BACnet IP to MS/TP router shall be used to improve JACE CPU resource usage by offloading the task of MS/TP token passing. Label IP range used on all routers and include panel laminated drawing.
5. Basis of Design: BACnet-Model
 - a. BASRTLX-B Modbus-Model BASGLX-M1
6. All native controllers shall be by the same manufacturer and reside on a separate, asynchronous secondary network. Similarly, all 3rd party integrations devices (Chillers, VFDs, humidifiers, etc.) shall reside on a separate, asynchronous secondary network.
7. The use of network repeaters should be avoided and shall require CCMS approval. Communication design shall not exceed 30 devices on a secondary network.

H. Special Network Architecture Requirements:

1. Air-Handling Systems: For control applications of an air-handling system that consists of air-handling unit(s) and VAV terminal units, include a dedicated LAN of application-specific controllers serving VAV terminal units connected directly to controller that is controlling air-handling system air-handling unit(s). Basically, create a DDC system LAN that aligns with air-handling system being controlled.

2.31 PORTABLE WORKSTATIONS

- A. Description: A self-contained computer designed to allow for normal use in different locations and conditions. Provide Portable workstation for all projects over \$1,000,000.
- B. Dell, HP or Lenovo
- C. Performance Requirements:
 1. Performance requirements may dictate equipment exceeding minimum requirements indicated.
 2. Energy Star compliant.
 3. Hardware and software shall support local down-loading to DDC controllers.
 4. Data transfer rate to DDC controller shall be at network speed.
- D. Processor:
 1. Minimum Processor Speed: 4.7 gigahertz
 2. RAM:
 - a. Capacity: 16 GB.

3. Hard Drive:
 - a. Number of Hard Drives: One
 - b. Capacity: 1 TB
4. Input and Output Ports:
 - a. Serial port.
 - b. Shared port for external keyboard or mouse.
 - c. Four USB 3.0 ports.
 - d. Ethernet port.
 - e. HDMI port.
- E. Battery:
 1. Capable of supporting operation of portable workstation for a minimum of 8 hours.
 2. Battery life of at least three years.
 3. Battery charge time of less than three hours.
- F. Keyboard:
 1. 85-key backlit keyboard.
 2. Full upper- and lowercase ASCII keyset.
- G. Integral Pointing Device: Touchpad with two buttons. Gesture enabled.
- H. Display:
 1. 15 inches diagonal or larger high-definition WLED color display.
 2. Antiglare screen.
 3. 1920 by 1080 pixel resolution.
 4. Brightness: 300 nits.
- I. Network Interfaces:
 1. Network Interface Card: Include card with connection, as application.
 - a. 10-100-1000 base TX Ethernet with RJ45 connector port.

- b. 100 base FX Ethernet with SC or ST port.
 - 2. Wireless:
 - a. Internal with integrated antenna, capable of supporting 802.11 a/b/g/n.
- J. Digital Video Disc Rewrite Recorder (DVD+/-RW):
 - 1. Compatible with DVD disks and data, audio, recordable and rewritable compact disks.
 - 2. Nominal Data Transfer Rates:
 - 3. 160-ms access time.
- K. Accessories:
 - 1. Backpack style carrying case

2.32 CEA-709.1-C NETWORK HARDWARE

- A. DDC CONTROLLERS
- B. DDC system shall consist of a combination of network controllers, programmable application controllers and application-specific controllers to satisfy performance requirements indicated.
- C. DDC controllers shall perform monitoring, control, energy optimization and other requirements indicated.
- D. DDC controllers shall use a multitasking, multiuser, real-time digital control microprocessor with a distributed network database and intelligence.
- E. Each DDC controller shall be capable of full and complete operation as a completely independent unit and as a part of a DDC system wide distributed network.
- F. Environment Requirements:
 - 1. Controller hardware shall be suitable for the anticipated ambient conditions.
 - 2. Controllers located in conditioned space shall be rated for operation at 32 to 120 deg F & 0 - 90% RH.
 - 3. Controllers located outdoors shall be rated for operation at 0 to 150 deg F & 0 - 90% RH.(Note manufacturers requirement for control modules that must be located inside buildings).
- G. Power and Noise Immunity:
 - 1. Controller shall operate at 90 to 110 percent of nominal voltage rating and shall perform an orderly shutdown below 80 percent of nominal voltage.

2. Operation shall be protected against electrical noise of 5 to 120 Hz and from keyed radios with up to 5 W of power located within 36 inches of enclosure.

H. Input and Output Point Interface:

1. Hardwired input and output points shall connect to network, programmable application and application-specific controllers.
2. Input and output points shall be protected so shorting of point to itself, to another point, or to ground will not damage controller.
3. Input and output points shall be protected from voltage up to 24 V of any duration so that contact will not damage controller.
4. AIs:
 - a. AIs shall include monitoring of low-voltage (zero- to 10-V dc), current (4 to 20 mA) and resistance signals from thermistor and RTD sensors.
 - b. AIs shall be compatible with, and field configurable to, sensor and transmitters installed.
 - c. Controller AIs shall perform analog-to-digital (A-to-D) conversion with a minimum resolution of 12 bits or better to comply with accuracy requirements indicated.
 - d. Signal conditioning including transient rejection shall be provided for each AI.
 - e. Capable of being individually calibrated for zero and span.
 - f. Incorporate common-mode noise rejection of at least 50 dB from zero to 100 Hz for differential inputs, and normal-mode noise rejection of at least 20 dB at 60 Hz from a source impedance of 10000 ohms.
5. AOs:
 - a. Controller AOs shall perform analog-to-digital (A-to-D) conversion with a minimum resolution of 10 bits or better to comply with accuracy requirements indicated.
 - b. Output signals shall have a range of 4 to 20 mA dc or zero- to 10-V dc as required to include proper control of output device.
 - c. Capable of being individually calibrated for zero and span.
 - d. AOs shall not exhibit a drift of greater than 0.4 percent of range per year.
6. BIs:
 - a. Controller BIs shall accept contact closures and shall ignore transients of less than 5-ms duration.

- b. Isolation and protection against an applied steady-state voltage of up to 180-V ac peak.
- c. BIs shall include a wetting current of at least 12 mA to be compatible with commonly available control devices and shall be protected against effects of contact bounce and noise.
- d. BIs shall sense "dry contact" closure without external power (other than that provided by the controller) being applied.
- e. Pulse accumulation input points shall comply with all requirements of BIs and accept up to 10 pulses per second for pulse accumulation. Buffer shall be provided to totalize pulses. Pulse accumulator shall accept rates of at least 20 pulses per second. The totalized value shall be reset to zero on operator's command.

7. BOs:

- a. Controller BOs shall include relay contact closures or triac outputs for momentary and maintained operation of output devices.
 - 1) Relay contact closures shall have a minimum duration of 0.1 second. Relays shall include at least 180 V of isolation. Electromagnetic interference suppression shall be provided on all output lines to limit transients to non-damaging levels. Minimum contact rating shall be 1 A at 24-V ac.
 - 2) Triac outputs shall include at least 180 V of isolation. Minimum contact rating shall be 1 A at 24-V ac.
- b. BOs shall include for two-state operation or a pulsed low-voltage signal for pulse-width modulation control.
- c. BOs shall be selectable for either normally open or normally closed operation.
- d. Include tristate outputs (two coordinated BOs) for control of three-point floating-type electronic actuators without feedback.
- e. Limit use of three-point floating devices to VAV terminal unit control applications, and other applications indicated on Drawings. Control algorithms shall operate actuator to one end of its stroke once every 24 hours for verification of operator tracking.

2.33 NETWORK CONTROLLERS

A. General Network Controller Requirements:

- 1. Include adequate number of controllers to achieve performance indicated.
- 2. System shall consist of one or more independent, standalone, microprocessor-based network controllers to manage global strategies indicated.

3. Controller shall have enough memory to support its operating system, database, and programming requirements.
 4. Data shall be shared between networked controllers and other network devices.
 5. Operating system of controller shall manage input and output communication signals to allow distributed controllers to share real and virtual object information and allow for central monitoring and alarms.
 6. Controllers that perform scheduling shall have a real-time clock.
 7. Controller shall continually check status of its processor and memory circuits. If an abnormal operation is detected, controller shall assume a predetermined failure mode and generate an alarm notification.
 8. Controllers shall be fully programmable.
- B. Communication:
1. Network controllers shall communicate with other devices on DDC system Level one network.
 2. Network controller also shall perform routing if connected to a network of programmable application and application-specific controllers.
- C. Operator Interface:
1. Controller shall be equipped with a service communications port for connection to a portable operator's workstation or mobile device.
 2. Local Keypad and Display:
 - a. Equip controller with local keypad and digital display for interrogating and editing data.
 - b. Use of keypad and display shall require security password.
- D. Serviceability:
1. Controller shall be equipped with diagnostic LEDs or other form of local visual indication of power, communication, and processor.
 2. Wiring and cable connections shall be made to field-removable, modular terminal strips or to a termination card connected by a ribbon cable.
 3. Controller shall maintain BIOS and programming information in event of a power loss for at least 72 hours.

2.34 PROGRAMMABLE APPLICATION CONTROLLERS

A. General Programmable Application Controller Requirements:

1. Include adequate number of controllers to achieve performance indicated.
2. Controller shall have enough memory to support its operating system, database, and programming requirements.
3. Data shall be shared between networked controllers and other network devices.
4. Operating system of controller shall manage input and output communication signals to allow distributed controllers to share real and virtual object information and allow for central monitoring and alarms.
5. Controllers that perform scheduling shall have a real-time clock.
6. Controller shall continually check status of its processor and memory circuits. If an abnormal operation is detected, controller shall assume a predetermined failure mode and generate an alarm notification.
7. Controllers shall be fully programmable.

B. Communication:

1. Programmable application controllers shall communicate with other devices on network.

C. Operator Interface:

1. Controller shall be equipped with a service communications port for connection to a portable operator's workstation or mobile device.
2. Local Keypad and Display:
 - a. Equip controller with local keypad and digital display for interrogating and editing data.
 - b. Use of keypad and display shall require security password.

D. Serviceability:

1. Controller shall be equipped with diagnostic LEDs or other form of local visual indication of power, communication, and processor.
2. Wiring and cable connections shall be made to field-removable, modular terminal strips or to a termination card connected by a ribbon cable.
3. Controller shall maintain BIOS and programming information in event of a power loss for at least 72 hours.

2.35 APPLICATION-SPECIFIC CONTROLLERS

- A. Description: Microprocessor-based controllers, which through hardware or firmware design are dedicated to control a specific piece of equipment. Controllers are not fully user-programmable but are configurable and customizable for operation of equipment they are designed to control.
 - 1. Capable of standalone operation and shall continue to include control functions without being connected to network.
 - 2. Data shall be shared between networked controllers and other network devices.
- B. Communication: Application-specific controllers shall communicate with other application-specific controller and devices on network, and to programmable application and network controllers.
- C. Operator Interface: Controller shall be equipped with a service communications port for connection to a portable operator's workstation. Connection shall extend to port on space temperature sensor that is connected to controller.
- D. Serviceability:
 - 1. Controller shall be equipped with diagnostic LEDs or other form of local visual indication of power, communication, and processor.
 - 2. Wiring and cable connections shall be made to field-removable, modular terminal strips or to a termination card connected by a ribbon cable.
 - 3. Controller shall use nonvolatile memory and maintain all BIOS and programming information in event of power loss.

2.36 CONTROLLER SOFTWARE

- A. General Controller Software Requirements:
 - 1. Software applications shall reside and operate in controllers. Editing of applications shall occur at operator workstations.
 - 2. I/O points shall be identified by up to 30 character point name and up to 16 character point descriptor. Same names shall be used at operator workstations.
 - 3. Control functions shall be executed within controllers using DDC algorithms.
 - 4. Controllers shall be configured to use stored default values to ensure fail-safe operation. Default values shall be used when there is a failure of a connected input instrument or loss of communication of a global point value.
- B. Security:
 - 1. Operator access shall be secured using individual security passwords and user names.

2. Passwords shall restrict operator to points, applications, and system functions as assigned by system manager.
 3. Operator log-on and log-off attempts shall be recorded.
 4. System shall protect itself from unauthorized use by automatically logging off after last keystroke. The delay time shall be operator-definable.
- C. Scheduling: Include capability to schedule each point or group of points in the system. For each VAV or FCU zone include the BACNET schedule object. Each schedule shall consist of the following:
1. Weekly Schedule:
 - a. Include separate schedules for each day of week.
 - b. Each schedule should include the capability for start, stop, optimal start, optimal stop, and night economizer.
 - c. Each schedule may consist of up to 10 events.
 - d. When a group of objects are scheduled together, include capability to adjust start and stop times for each member.
 2. Exception Schedules:
 - a. Include ability for operator to designate any day of the year as an exception schedule.
 - b. Exception schedules may be defined up to a year in advance. Once an exception schedule is executed, it will be discarded and replaced by regular schedule for that day of week.
 3. Holiday Schedules:
 - a. Include capability for operator to define up to 99 special or holiday schedules.
 - b. Schedules may be placed on scheduling calendar and will be repeated each year.
 - c. Operator shall be able to define length of each holiday period.
- D. System Coordination:
1. Include standard application for proper coordination of equipment.
 2. Application shall include operator with a method of grouping together equipment based on function and location.
 3. Group may then be used for scheduling and other applications.
- E. Binary Alarms:

1. Each binary point shall be set to alarm based on operator-specified state.
 2. Include capability to automatically and manually disable alarming.
- F. Analog Alarms:
1. Each analog object shall have both high and low alarm limits.
 2. Alarming shall be able to be automatically and manually disabled.
- G. Alarm Reporting:
1. Operator shall be able to determine action to be taken in event of an alarm.
 2. Alarms shall be routed to appropriate operator workstations based on time and other conditions.
 3. Alarm shall be able to start programs, print, be logged in event log, generate custom messages, and display graphics.
- H. Remote Communication:
1. System shall have ability to dial out in the event of an alarm.
- I. Sequencing: Include application software based on sequences of operation indicated to properly sequence chillers, boilers, and other applicable HVAC equipment.
- J. Control Loops:
1. Support any of the following control loops, as applicable to control required:
 - a. Two-position (on/off, open/close, slow/fast) control.
 - b. Proportional control.
 - c. Proportional plus integral (PI) control.
 - d. Proportional plus integral plus derivative (PID) control.
 - 1) Include PID algorithms with direct or reverse action and anti-windup.
 - 2) Algorithm shall calculate a time-varying analog value used to position an output or stage a series of outputs.
 - 3) Controlled variable, set point, and PID gains shall be operator-selectable.
 - e. Adaptive (automatic tuning).

- K. Staggered Start: Application shall prevent all controlled equipment from simultaneously restarting after a power outage. Order which equipment (or groups of equipment) is started, along with the time delay between starts, shall be operator-selectable.
- L. Energy Calculations:
 - 1. Include software to allow instantaneous power or flow rates to be accumulated and converted to energy usage data.
 - 2. Include an algorithm that calculates a sliding-window average (rolling average). Algorithm shall be flexible to allow window intervals to be operator specified (such as 15, 30, or 60 minutes).
 - 3. Include an algorithm that calculates a fixed-window average. A digital input signal shall define start of window period (such as signal from utility meter) to synchronize fixed-window average with that used by utility.
- M. Anti-Short Cycling:
 - 1. BO points shall be protected from short cycling.
 - 2. Feature shall allow minimum on-time and off-time to be selected.
- N. On and Off Control with Differential:
 - 1. Include an algorithm that allows a BO to be cycled based on a controlled variable and set point.
 - 2. Algorithm shall be direct- or reverse-acting and incorporate an adjustable differential.
- O. Run-Time Totalization:
 - 1. Include software to totalize run-times for all BI points.
 - 2. A high run-time alarm shall be assigned, if required, by operator.

2.37 RELAYS

- A. General-Purpose Relays:
 - 1. Relays shall be heavy duty and rated for at least 10 A at 250-V ac and 60 Hz.
 - 2. Relays shall be either double pole double throw (DPDT) or three-pole double throw, depending on the control application.
 - 3. Use a plug-in-style relay with an eight-pin octal plug for DPDT relays and an 11-pin octal plug for three-pole double-throw relays.
 - 4. Construct the contacts of either silver cadmium oxide or gold.

5. Enclose the relay in a clear transparent polycarbonate dust-tight cover.
6. Relays shall have LED indication and a manual reset and push-to-test button.
7. Performance:
 - a. Mechanical Life: At least 10 million cycles.
 - b. Electrical Life: At least 100,000 cycles at rated load.
 - c. Pickup Time: 15 ms or less.
 - d. Dropout Time: 10 ms or less.
 - e. Pull-in Voltage: 85 percent of rated voltage.
 - f. Dropout Voltage: 50 percent of nominal rated voltage.
 - g. Power Consumption: 2 VA.
 - h. Ambient Operating Temperatures: Minus 40 to 115 deg F.
8. Equip relays with coil transient suppression to limit transients to non-damaging levels.
9. Plug each relay into an industry-standard, 35-mm DIN rail socket. Plug all relays located in control panels into sockets that are mounted on a DIN rail.
10. Relay socket shall have screw terminals. Mold into the socket the coincident screw terminal numbers and associated octal pin numbers.

B. Multifunction Time-Delay Relays:

1. Relays shall be continuous duty and rated for at least 10 A at 240-V ac and 60 Hz.
2. Relays shall be DPDT relay with up to eight programmable functions to provide on/off delay, interval and recycle timing functions.
3. Use a plug-in-style relay with either an 8- or 11-pin octal plug.
4. Construct the contacts of either silver cadmium oxide or gold.
5. Enclose the relay in a dust-tight cover.
6. Include knob and dial scale for setting delay time.
7. Performance:
 - a. Mechanical Life: At least 10 million cycles.
 - b. Electrical Life: At least 100,000 cycles at rated load.

- c. Timing Ranges: Multiple ranges from 0.1 seconds to 100 minutes.
 - d. Repeatability: Within 2 percent.
 - e. Recycle Time: 45 ms.
 - f. Minimum Pulse Width Control: 50 ms.
 - g. Power Consumption: 5 VA or less at 120-V ac.
 - h. Ambient Operating Temperatures: Minus 40 to 115 deg F.
8. Equip relays with coil transient suppression to limit transients to non-damaging levels.
 9. Plug each relay into an industry-standard, 35-mm DIN rail socket. Plug all relays located in control panels into sockets that are mounted on a DIN rail.
 10. Relay socket shall have screw terminals. Mold into the socket the coincident screw terminal numbers and associated octal pin numbers.

C. Latching Relays:

1. Relays shall be continuous duty and rated for at least 10 A at 250-V ac and 60 Hz.
2. Relays shall be either DPDT or three-pole double throw, depending on the control application.
3. Use a plug-in-style relay with a multibladed plug.
4. Construct the contacts of either silver cadmium oxide or gold.
5. Enclose the relay in a clear transparent polycarbonate dust-tight cover.
6. Performance:
 - a. Mechanical Life: At least 10 million cycles.
 - b. Electrical Life: At least 100,000 cycles at rated load.
 - c. Pickup Time: 15 ms or less.
 - d. Dropout Time: 10 ms or less.
 - e. Pull-in Voltage: 85 percent of rated voltage.
 - f. Dropout Voltage: 50 percent of nominal rated voltage.
 - g. Power Consumption: 2 VA.
 - h. Ambient Operating Temperatures: Minus 40 to 115 deg F.

7. Equip relays with coil transient suppression to limit transients to non-damaging levels.
8. Plug each relay into an industry-standard, 35-mm DIN rail socket. Plug all relays located in control panels into sockets that are mounted on a DIN rail.
9. Relay socket shall have screw terminals. Mold into the socket the coincident screw terminal numbers and associated octal pin numbers.

D. Current Sensing Relay:

1. Monitors ac current.
2. Independent adjustable controls for pickup and dropout current.
3. Energized when supply voltage is present and current is above pickup setting.
4. De-energizes when monitored current is below dropout current.
5. Dropout current is adjustable from 50 to 95 percent of pickup current.
6. Include a current transformer, if required for application.
7. House current sensing relay and current transformer in its own enclosure. Use NEMA 250, Type 12 enclosure for indoors and NEMA 250, Type 4 for outdoors.

E. Combination On-Off Status Sensor and On-Off Relay:

1. Description:
 - a. On-off control and status indication in a single device.
 - b. LED status indication of activated relay and current trigger.
 - c. Closed-Open-Auto override switch located on the load side of the relay.
2. Performance:
 - a. Ambient Temperature: Minus 30 to 140 deg F.
 - b. Voltage Rating: Single-phase loads rated for 300-V ac. Three-phase loads rated for 600-V ac.
3. Status Indication:
 - a. Current Sensor: Integral sensing for single-phase loads up to 20 A and external solid or split sensing ring for three-phase loads up to 150 A.
 - b. Current Sensor Range: As required by application.

- c. Current Set Point: Adjustable (adjust to send signal on current threshold above motor operating under no load).
- d. Current Sensor Output:
 - 1) Solid-state, single-pole double-throw contact rated for 30-V ac and dc and for 0.4 A.
 - 2) Solid-state, single-pole double-throw contact rated for 120-V ac and 1.0 A.
 - 3) Analog, zero- to 5- or 10-V dc.
 - 4) Analog, 4 to 20 mA, loop powered.
- 4. Relay: Single-pole double-throw, continuous-duty coil; rated for 10-million mechanical cycles.
- 5. Enclosure: NEMA 250, Type 1 enclosure.

2.38 ELECTRICAL POWER DEVICES

A. Transformers:

- 1. Transformer shall be sized for the total connected load, plus an additional 25 percent of connected load.
- 2. Transformer shall be at least 40 VA but less than 100 VA (Class II)
- 3. All transformers to be 24 VAC
- 4. Line Voltage Transformers shall not be utilized.
- 5. Transformer shall have both primary and secondary fuses.

2.39 RACEWAYS

- A. Provide Green Conduit and Green junction box covers for all CCMS work.
- B. Comply with requirements in Section 260533 "Raceways and Boxes for Electrical Systems" for electrical power raceways and boxes.
- C. Comply with requirements in Section 270528 "Pathways for Communications Systems" for raceways for balanced twisted pair cables and optical fiber cables.

2.40 ACCESSORIES

A. Pneumatic Pressure Gages:

1. Pressure gages shall a 1.5-inch diameter face for pressures up through 30 psig and 2.5-inch-diameter face for greater pressures.
2. Include separate gages for branch pressure and main pressure lines.
3. White dial face with black printing.
4. Include 1-psig increment for scale ranges through 30 psig and 2-psig increment for larger ranges.
5. Accuracy: Within 1 percent of full-scale range.

B. Pressure Electric Switches:

1. Diaphragm-operated snap acting switch.
2. Set point adjustable from 3 to 20 psig.
3. Differential adjustable from 2 to 6 psig.
4. Rated for resistance loads at 120-V ac.
5. Body and switch housing shall be metal.

C. Damper Blade Limit Switches:

1. Sense positive open and/or closed position of the damper blades.
2. NEMA 250, Type 13, oil-tight construction.
3. Arrange for the mounting application.
4. Additional waterproof enclosure when required by its environment.
5. Arrange to prevent "over-center" operation.

D. I/P and E/P Transducers:

1. Commercial Grade:
 - a. The transducer shall convert an AO signal to a stepped pneumatic signal. Unless otherwise required by the operating sequence, use a 3- to 15-psig pneumatic signal for pneumatic actuation.
 - b. Construct the entire assembly so that shock and vibration will neither harm the transducer nor affect its accuracy.

- c. Transducer shall have auto/manual output switch, manual output control and an output pressure gage.
 - d. Accuracy: Within 1.0 percent of the output span.
 - e. Linearity: Within 0.5 percent of the output span.
 - f. Output Capacity: Not less than 550 scim at 15 psig.
 - g. Transducer shall have separate zero and span calibration adjustments.
 - h. The transducer shall withstand up to 40 psig of supply pressure without damage.
 - i. For use on only modulating pneumatic outputs that are associated with terminal units, including fan-coil units, VAV units, unit heaters as applicable..
2. Industrial Grade:
- a. The transducer shall convert an AO signal to a proportional pneumatic signal. Unless otherwise required by the operating sequence, use a 3- to 15-psig pneumatic signal for pneumatic actuation. A stepped pneumatic signal is unacceptable.
 - b. Construct the entire assembly so that shock and vibration will neither harm the transducer nor affect its accuracy.
 - c. Suitable for operation in an ambient temperature range of minus 40 to 150 deg F.
 - d. Accuracy: Within 0.5 percent of the output span.
 - e. Linearity: Within 0.5 percent of the output span.
 - f. Output Capacity: Not less than 5 scfm.
 - g. Transducer shall have zero and span calibration adjustments.
 - h. The transducer shall withstand up to 50 psig of supply pressure without damage.
 - i. For use on all modulating pneumatic outputs, not requiring a commercial-grade transducer.
- E. E/P Switch:
- 1. Construct the body of cast aluminum or brass; three pipe body (common, normally open, and normally closed).
 - 2. Internal construction of steel, copper or brass.
 - 3. Air Connections: Barb.

4. Rating of 30 psig when installed in systems below 25 psig and of 150 psig when installed in systems above 25 psig.
5. Include coil transient suppression.

F. Instrument Enclosures:

1. Include instrument enclosure for secondary protection to comply with requirements indicated in "Performance Requirements" Article.
2. NRTL listed and labeled to UL 50.
3. Sized to include at least 25 percent spare area on subpanel.
4. Instrument(s) mounted within enclosure on internal subpanel(s).
5. Enclosure face with engraved, laminated phenolic nameplate for each instrument within enclosure.
6. Enclosures housing pneumatic instruments shall include main pressure gage and a branch pressure gage for each pneumatic device, installed inside.
7. Enclosures housing multiple instruments shall route tubing and wiring within enclosure in a raceway having a continuous removable cover.
8. Enclosures larger than 12 inches shall have a hinged full-size face cover.
9. Equip enclosure with lock and common key.

G. Manual Valves:

1. Needle Type:
 - a. PTFE packing.
 - b. Construct of brass for use with copper and polyethylene tubing and of stainless steel for use with stainless-steel tubing.
 - c. Aluminum T-bar handle.
 - d. Include tubing connections.
2. Ball Type:
 - a. Body: Bronze ASTM B62 or ASTM B61.
 - b. Ball: Type 316 stainless steel.
 - c. Stem: Type 316 stainless steel.

- d. Seats: Reinforced PTFE.
- e. Packing Ring: Reinforced PTFE.
- f. Lever: Stainless steel with a vinyl grip.
- g. 600 WOG.
- h. Threaded end connections.

PART 3 - EXECUTION

3.1 EXAMINATION

- A. Examine substrates and conditions for compliance with requirements for installation tolerances and other conditions affecting performance of the Work.
 - 1. Verify compatibility with and suitability of substrates.
- B. Examine roughing-in for products to verify actual locations of connections before installation.
 - 1. Examine roughing-in for instruments installed in piping to verify actual locations of connections before installation.
 - 2. Examine roughing-in for instruments installed in duct systems to verify actual locations of connections before installation.
- C. Examine walls, floors, roofs, and ceilings for suitable conditions where product will be installed.
- D. Prepare written report, endorsed by Installer, listing conditions detrimental to performance of the Work.
- E. Proceed with installation only after unsatisfactory conditions have been corrected.

3.2 RESPONSIBILITIES (ALSO STATED IN SECTION 1.3)

- A. The BAS Contractor shall be responsible for the following:
 - 1. All wiring from mechanical and electrical alarms and functions to report these alarms and functions to the BAS head-end.
 - 2. All line and low voltage wiring for the control of all HVAC motors (whether individual or as part of packaged equipment), automatic control valves, and dampers, including: wiring for EPs, PEs, relays, controllers, thermostats, actuating devices, unit heater controls, and cabinet heater controls.
 - 3. All power supply wiring for all BAS components.

B. The Electrical Contractor shall be responsible for the following as they relate to the BAS:

1. The electrical trade shall provide “lock-out stop” control wiring.
2. A separate system of wiring for smoke and fire control of motors which are to be automatically and/or manually controlled by the fire protective alarm system will be run to the motor starters or BAS enclosures by the electrical trade.
3. A separate system of wiring for smoke and fire control of dampers that are to be automatically and/or manually controlled directly by the fire protective alarm system (i.e., not in response to motor operation), will be run by the electrical trades except for the power supply wiring to electric damper motors that is specifically excluded from the electrical trade work.

3.3 DDC SYSTEM INTERFACE WITH EXISTING SYSTEMS

A. Interface with Existing Systems:

1. DDC systems shall interface existing systems to achieve integration.
2. Monitoring and Control of DDC System by Existing Control System:
 - a. DDC system performance requirements shall be satisfied when monitoring and controlling DDC system by existing control system.
 - b. Operator of existing system shall be able to upload, download, monitor, trend, control and program every input and output point in DDC system from existing control system using existing control system software and operator workstations.
 - c. Remote monitoring and control from existing control system shall not require operators of existing control system to learn new software.
 - d. Interface of DDC system into existing control system shall be transparent to operators of existing control system and allow operators to program, monitor, and control DDC system from any operator workstation connected to existing control system.
3. Integration of Existing Control System into DDC System:
 - a. Existing control system performance requirements shall be satisfied when monitoring and controlling existing control system through DDC system.
 - b. Operator shall be able to upload, download, monitor, alarm, report, trend, control and program every input and output point in existing system from DDC system using operator workstations and software provided. The combined systems shall share one database.

- c. Interface of existing control system I/O points into DDC system shall be transparent to operators. All operational capabilities shall be identical regardless of whether I/O already exists or I/O is being installed..

3.4 GENERAL INSTALLATION REQUIREMENTS

- A. Install products to satisfy more stringent of all requirements indicated.
- B. Install products level, plumb, parallel, and perpendicular with building construction. Sensor Installation: All sensors and transmitters shall be located in accessible locations that do not require system shutdown for calibration. Locate all remote transmitters in control panels 5' above finished floor. When mounting field transmitters use spaces above doorways so furniture does not block access.
- C. All ATC Sensors and Control Relays shall be identified by an exterior tag, consistent with identification within the ATC O&M manual. Control conduit will be identified by green conduit and covers.
- D. Spare Capacity: All installations involving new upper level, main level, ALN, or BLN controllers should leave at least 10 percent spare point of each point type with no less than 1 of each, (BI, BO, AI, and AO), specifically for each type of point provided on the controller. These point types are defined below:
 1. Binary Input (BI): An on/off indication that has a maximum cycle rate of 1 Hz. This is typically sensing a contact closure
 2. Binary Output (BO): A contact closure on the controller that will cause an action in the system
 3. Analog Input (AI): A continuously varying voltage or amperage signal that is varied by a sensor in relation to a sensed variable. This signal is processed in the controller after an analog-to-digital converter on the controller that converts the analog signal to a digital value
 4. Analog Output
- E. Trend Database Definitions. The following represents the default trend history data interval criteria:
 1. Analog point types shall have a sample interval of 15 minutes with a minimum of 672 samples, First-In First-Out (FIFO) sliding window within the controller.
 2. Binary and Multi-State Variable point types shall be defined to record Change of State and Change of Variable respectively.
 3. File upload to the server shall automatically be performed on a daily basis.
 4. Trend data uploaded to the primary server level shall be maintained indefinitely.

5. The following examples represents the default trend data definition criteria:
 - a. LAB Exhaust Systems:
 - b. Fan Command (DO)
 - c. Fan Status (DI)
 - d. Duct Static Pressure (AI) (If Applicable)
 - e. Air Volumes (AI) (If Applicable)
 - f. VFD Speed (AO) (If Applicable)
 - g. Bypass Damper Control Position (AO) (If Applicable)
6. Variable Volume HX/Pumps:
 - a. Pump Command (DO)
 - b. Pump Status (DI) or AI (Amps)
 - c. Supply Temperature (AI)
 - d. Return Temperature (AI)
 - e. System Pressure (AI)
 - f. Flow (AI) (If Applicable)
 - g. VFD Speed (AO)
 - h. Bypass Valve Control Position (AO)
7. Constant Volume HX/Pumps:
 - a. Pump Command (DO)
 - b. Pump Status (DI) or AI (Amps)
 - c. Supply Temperature (AI)
 - d. Return Temperature (AI)
8. Constant Volume Air Handling Unit:
 - a. Fan Command (DO)
 - b. Fan Status (DI) or AI (Amps)

- c. Zone Temperature (AI)
 - d. Supply Temperature (AI)
 - e. Return Temperature (AI)
 - f. Mixed Air Temp (AI)
 - g. Freeze Stat (DI)
 - h. Valve Control Position (AO)
 - i. Smoke Detector (DI)
 - j. High/Low Static Pressure Safety (DI) (As required)
9. Variable Volume Air Handling Unit:
- a. Fan Command (DO)
 - b. Fan Status (DI) or AI (Amps)
 - c. Duct Static Pressure (AI)
 - d. Supply Temperature (AI)
 - e. Return Temperature (AI)
 - f. Mixed Air Temp (AI)
 - g. Air Volumes (AI) (If Applicable)
 - h. Freeze Stat (DI)
 - i. Duct Static Pressure Setpoint (SP) (If Optimized)
10. Supply Temperature Setpoint (SP) (If Optimized)
- a. Smoke Detector (DI)
 - b. High/Low Static Pressure Safety (DI) (As required)
11. Terminal Units: Variable Air Volume (VAV) and Fan Coil Units (FCU):
- a. Zone Temperature (AI)
 - b. Supply Temperature (AI)
 - c. Air Volume Input (AI)

- d. Air Volume Setpoint (AV)
 - e. Cooling %
 - f. Heating %
 - g. Occupancy
- F. Demand Limit: The CCMS BAS shall be programmed to include three building-wide global/group demand limiting command levels to allow the CCMS operator, with administrator password access, to manually initiate the demand limiting sequence. The sequence shall be written to allowing for additional logic allowing automatic level indexing in addition to the manual user intervention.
- 1. A demand limit Group command shall include an AHU and/or its associated VAV's.
 - 2. Group Commands: From a common GUI screen, the CCMS operator shall be capable of selecting the following functions per group.
 - a. Enable/Disable the demand limit sequence.
 - b. Set Duration of an event through time schedule.
 - c. Select the demand limit level.
 - 3. Levels:
 - a. Level 1: Shall command the group of VAV heating and cooling setpoint offset values from 0 °F to -3°F/+ 3°F, respectively
 - b. Level 2: Shall force the terminal units to minimum air flow by commanding the group of VAV heating and cooling setpoint offset values from 0 °F to -15°F/+ 15°F, respectively AND Command the associated AHU into recirculation mode (outside air damper closed, return air open) and reset the supply air temperature setpoint to 65 °F (adj.)
 - c. Level 3: Shall command the group of VAVs and associated AHU into the Unoccupied Mode
 - d. Level 4: Shall command mixed box AHU Dampers to recirculate and associated exhaust fans off. VAV shall remain in Normal Mode
 - 4. Terminal Unit Exemptions: The system shall allow the CCMS operator to set an individual VAV's to an Exempt Status where the Zone Temperature setpoint offsets shall remain at 0 °F for the Level 1 or 2 demand limit modes. The Exemption shall not apply for the demand level 3 mode.
 - 5. Summary Reports:
 - a. The user shall be able to identify the following in summary form.

- b. Terminal Units set to exempt status
 - 1) Level 1 Offsets
 - 2) Level 2 Offsets
- 6. Graphical User Interface (GUI) representation of Demand Limit summary page:
 - a. All relevant points shall be audit and trend logged.
 - b. Graphical representation of the building profile shall include the following summary data:
 - c. VAV Group
 - 1) Total number of VAV's in group.
 - 2) Total primary air volume (input).
 - 3) Total primary air volume (output).
 - 4) Average Heating and Cooling %.
 - 5) Minimum, Maximum and average Zone Temperatures.
 - 6) Minimum, Maximum and Average Zone Temperatures setpoints.
 - 7) Global VAV Offset setpoints.
 - d. Associated AHU
 - 1) Supply air temp and setpoint.
 - 2) Static pressure and setpoint.
 - 3) Chilled and hot water valve positions.
 - 4) Supply and return fan VFD speed.
 - 5) Outside and return air damper position.
 - e. General
 - 1) Demand Limit Mode Level
 - 2) Outside Air Temperature & Humidity
 - 3) Steam or Hot Water power and energy meter data (if available).
 - 4) Chilled water power and energy meter data (if available).

- 5) Electrical power and energy meter data (if available).
 - 6) Building vitals (identification of cooling and heating plant, building number, use, size, year constructed).
- G. VAV Graphical Summary The ATC contractor shall provide a VAV graphical summary screen(s) which includes the following points:
1. Zone Temperature
 2. Zone Temperature Cooling Setpoint
 3. Zone Temperature Heating Setpoint
 4. Supply Temperature
 5. Supply Control Volume (controller output (cfm))
 6. Supply Volume (controller input (cfm))
 7. Cooling %
 8. Heating %
 9. Location room number for thermostat.
- H. BACnet over Campus IP Addressing Scheme :
1. Each BACnet Device Object Instance on the Campus Intra-network must be exclusive for each device. Within the University of Maryland, College Park Campus managed IP networks two IP subnet domains have been allocated for the CCMS BAS Systems (10.136 and 10.137 for ALC, and Tridium 10.226.x.x).
 2. The Tridium BAS contractors shall coordinate with the CCMS System group for network communication topology and BACnet numbering for existing BAS infrastructure. Further, these contractors shall use the Niagara communication protocol, not BACnet, to pass data between the Tridium N4 Server and the building JACES. BACnet data shall only be transferred within the Building BAS topology.
 3. The BAS contractor shall coordinate with the CCMS System group for network communication topology and BACnet numbering for existing and New BAS infrastructure and for instances where 3rd Party integrated systems cannot be addressed in accordance with the established BACnet addressing format.
 - a. A BACnet network is made up of one or more IP subnets.
 - b. Devices do not know, or at least do not need to know, their BACnet network number (unless the device is a BACnet router).
 - c. Devices have a unique address.

d. Media Access Control (MAC)

I. Campus BACnet Numbering Scheme:

1. The BAS contractor shall conform to the following BACnet Network and Device Instance numbering format scheme, based on Cornell model as described in the Nov 2007 ASHRAE Journal.
2. Where after reviewing the controls submittal and validating the network architecture for a given project the university would then allocate a range of BACnet Network Numbers and Device Instance Numbers based on the following:
3. The format for the Network Number is SFFFN where S=Site (1=Main Campus, 2=Main Campus Extended Network, 3= Off Campus) FFF= Facility (Building) Number (Always 3 digits – range 000-999) N=Network Number (Always 1 digit - range 0-9)
4. The format for the Device Instance Number is SFFFNDD where DD=Device Number (Always 2 digits - range 00-99)
5. In case where multiple routers are used in a building (FFF) the S and N digits may be combined to extend the network (range 10-39)
6. The BAS contractor shall coordinate with the CCMS System group for network communication topology and BACnet numbering for existing BAS infrastructure and for instances where 3rd Party integrated systems cannot be addressed in accordance with the established BACnet addressing format.

J. Campus BACnet Numbering Scheme:

1. For Tridium N4 applications, the contractors shall provide the Pass Phrase for the JACE platform.

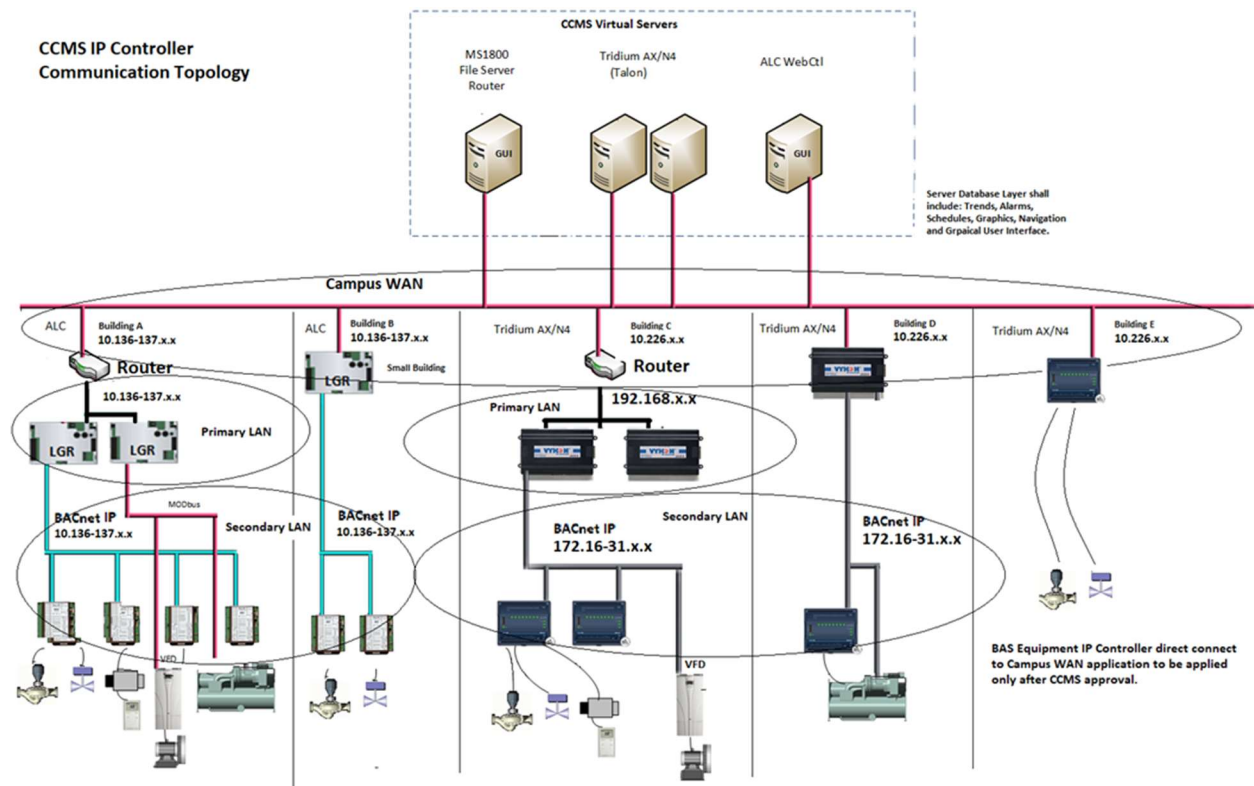

CCMS/BAS Campus Wide Area Network IP

K. BAS Routers Primary Building BAS Local Area Network (LAN)

1. Any BAS Tridium based JACE or associated router connected to the Campus WAN shall be assigned a private static IP address in the 10.226.x.x/19 range.
2. Building ALC and AX/N4 BAS platforms shall follow the IP addressing format as shown in the CCMS IP Controller Communication Topology. Provide the sufficient number of switches and routers to reduce network latency to below 500ms . Secondary LAN shall be isolated from the primary LAN. Primary LAN shall be isolated from the campus WAN via router.

L. Graphic Equipment Representation

1. All equipment representations (fans, pumps, dampers, valves, chillers, etc.) shall include animated scalable vector graphical (SVG) representations based on operating input status or position. Additionally, representations shall include text point descriptions and point engineering units.
2. All sensor representations (temperature, pressure, humidity, flow, etc.) shall include scalable vector graphical (SVG) representations based on operating value reading. Additionally, representations shall include text point descriptions and point engineering units. In all cases communication status (stale, fault, failure, alarm, disabled), controlled

- point commanded state (auto, override) shall be represented based on background color code.
3. BAS Graphical representations shall include summaries based on system type including Chilled Water plants, Hot Water Plants, Air Handling Units, Fan coil and Variable Air Volume terminal units, Lighting and Miscellaneous systems.
 4. Flow Diagram representations shall include all associated hardwired points, relevant setpoints and indexable parameters along with background color change based on parameter status such as fault, manual and alarm. Associated system time schedules shall be adjustable from flow diagram graphic. Terminal unit floor graphics shall display zone temperature and color gradient representation from red to blue based on error from setpoint.
 5. VAV Graphical Summary: The BAS contractor shall provide a VAV graphical summary screen(s) which includes the following points:
 - a. Zone Temperature
 - b. Zone Temperature Cooling Setpoint
 - c. Zone Temperature Heating Setpoint
 - d. Supply Temperature
 - e. Supply Control Volume (controller output (cfm))
 - f. Supply Volume (controller input (cfm))
 - g. Cooling %/Heating %
 - h. Location room number

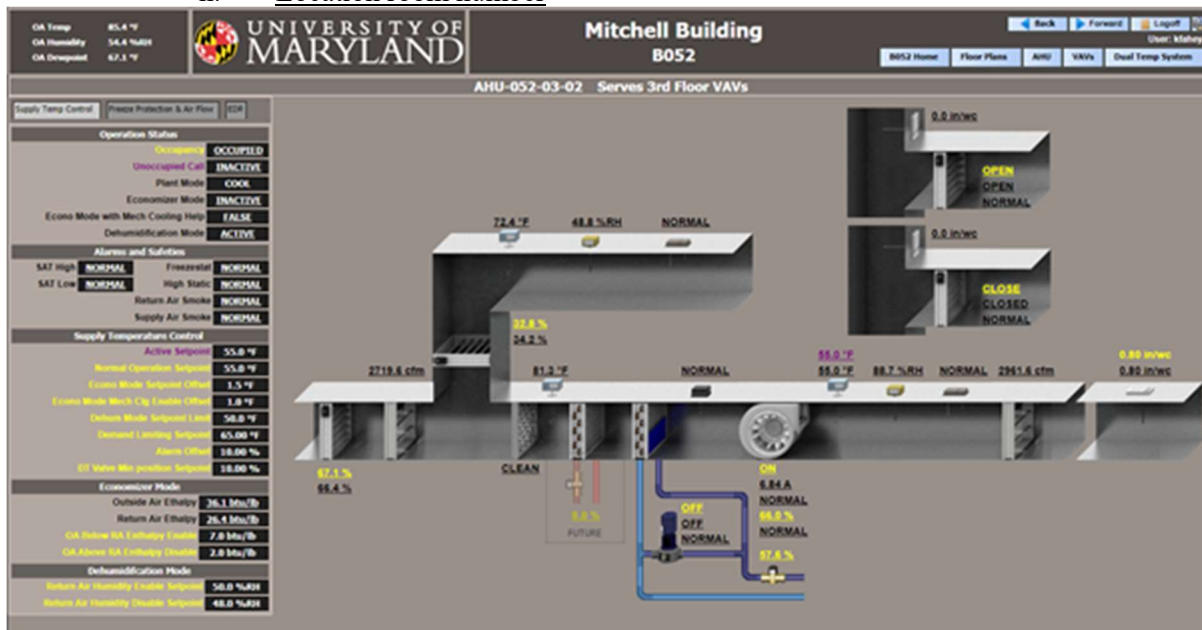

AHU Flow Diagram

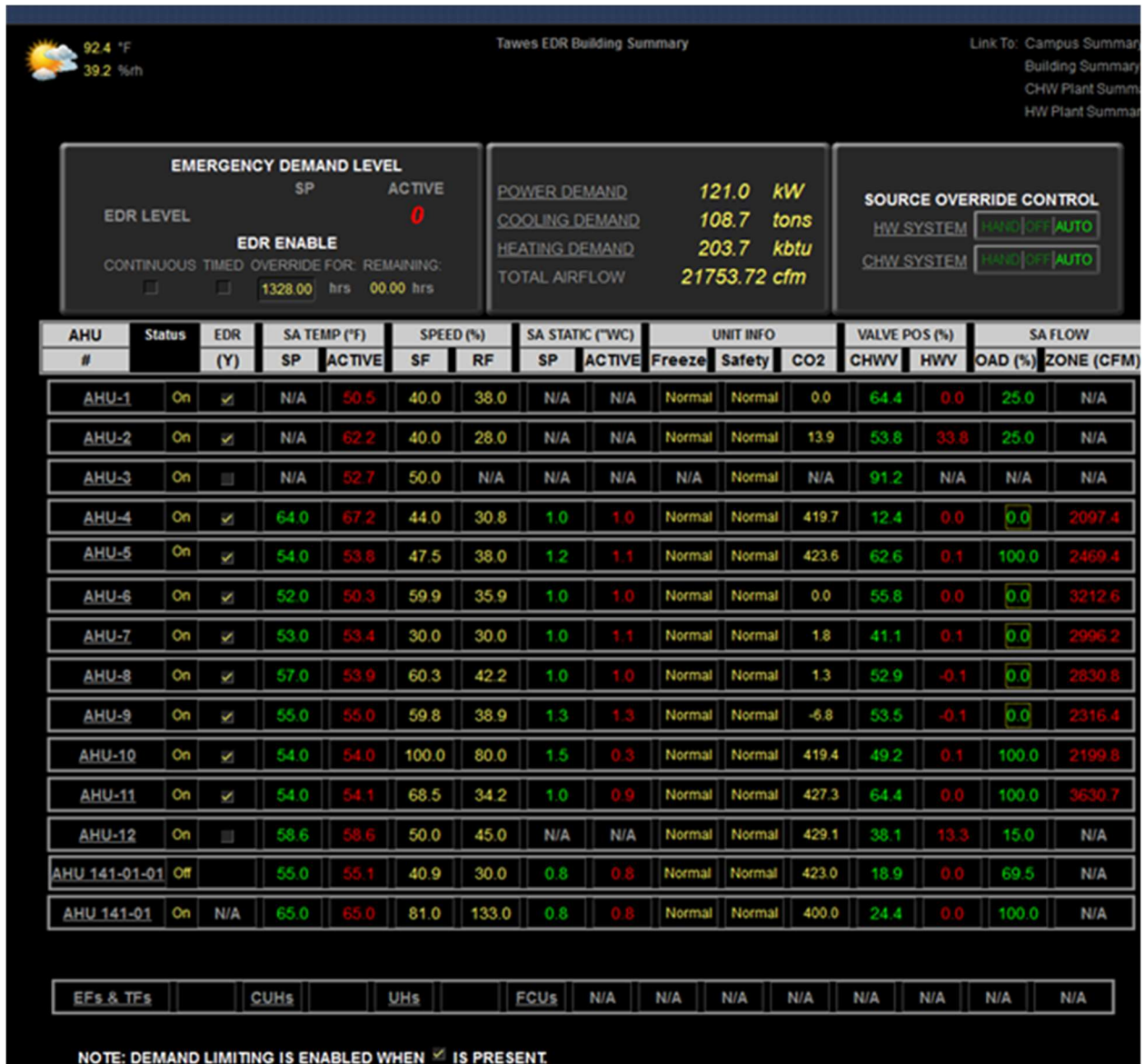

AHU Summary (Example):

Unit	Occupancy	Zone Temp	Active Cool SP	Active Heat SP	Air Flow	Flow Control	Damper	Heat	Supply Air	Area Served
VAV-3101	Occupied	72.3 °F	75.0 °F	71.0 °F	455.9 cfm	460.0 cfm	39.9 %	0.0 %	56.9 °F	Room 3101
VAV-3102	Occupied	73.0 °F	75.0 °F	71.0 °F	54.8 cfm	55.0 cfm	26.2 %	0.0 %	57.5 °F	Offices 3102 & 3104
VAV-3107	Occupied	80.3 °F	75.0 °F	71.0 °F	100.5 cfm	100.0 cfm	36.7 %	0.0 %	57.2 °F	Offices 3105 & 3107
VAV-3108	Occupied	80.1 °F	75.0 °F	71.0 °F	64.9 cfm	65.0 cfm	30.1 %	0.0 %	57.3 °F	Offices 3106 & 3108
VAV-3110	Occupied	79.1 °F	75.0 °F	71.0 °F	100.8 cfm	100.0 cfm	32.8 %	0.0 %	56.8 °F	Conference 3110
VAV-3112	Occupied	71.0 °F	75.0 °F	71.0 °F	206.5 cfm	210.0 cfm	48.4 %	28.1 %	72.0 °F	Office 3112 & Reception 3118
VAV-3114	Occupied	77.5 °F	75.0 °F	71.0 °F	309.3 cfm	315.0 cfm	78.9 %	21.4 %	73.4 °F	Offices 3114 & 3116
VAV-3115	Occupied	71.7 °F	75.0 °F	71.0 °F	111.7 cfm	110.0 cfm	42.4 %	0.0 %	56.9 °F	Office 3117 & Programs 3115
VAV-3115A	Occupied	79.6 °F	75.0 °F	71.0 °F	0.0 cfm	50.0 cfm	0.0 %	0.0 %	71.7 °F	Office 3115A & Lactation 3119
VAV-3115C	Occupied	78.9 °F	75.0 °F	71.0 °F	132.3 cfm	130.0 cfm	41.0 %	0.0 %	56.8 °F	Offices 3115C & 3115D
VAV-3115F	Occupied	71.0 °F	75.0 °F	71.0 °F	133.2 cfm	135.0 cfm	75.3 %	0.0 %	66.9 °F	Offices 3115E & 3115F
VAV-3115G	Occupied	78.7 °F	75.0 °F	71.0 °F	55.5 cfm	55.0 cfm	27.4 %	0.0 %	57.7 °F	Office 3115B
VAV-3120	Occupied	71.0 °F	75.0 °F	71.0 °F	286.6 cfm	115.0 cfm	64.0 %	42.1 %	66.7 °F	Copy/Pantry 3120
VAV-3125	Occupied	72.7 °F	75.0 °F	71.0 °F	84.5 cfm	85.0 cfm	35.9 %	0.0 %	67.1 °F	Office 3125
VAV-3125A	Occupied	77.7 °F	75.0 °F	71.0 °F	106.3 cfm	105.0 cfm	28.2 %	0.0 %	57.5 °F	Offices 3125A & 3125B
VAV-3125D	Occupied	74.4 °F	75.0 °F	71.0 °F	983.7 cfm	980.0 cfm	61.3 %	33.6 %	72.4 °F	Offices 3125C & 3125D
VAV-3125E	Occupied	71.9 °F	75.0 °F	71.0 °F	168.5 cfm	165.0 cfm	44.8 %	0.0 %	56.7 °F	Waiting 3125

VAV Summary

M. Metering

1. Meters shall be approved by FM Engineering and Energy Meter Shop and College Park Energy. Refer to the DCFS Utility Metering Section 33.00.00
2. The BAS Vendor shall install adequate controllers to be able to read and display a minimum of 40-integrated points from each flow computer and meter.
3. The BAS communications to these meters are accomplished via MODBUS or BACNET over RS485. Communications protocol for each steam meter shall be coordinated with the Meter Shop.
4. The UMD Meter shop will approve points list for each meter and display format for each point (KWH, Tons, BTUs, Etc.).
5. Integrate and trend the instantaneous point and totalized points are required for energy and consumption points.
6. Calculation of totalized data using instantaneous values and pulses leads to a constant reconciliation effort between the BAS and Physical Meter and shall not be used.
7. Refer to Division 23 Section “Energy Meters” for product data.

N. Additional Meter Information:

1. Trending of meter data and storage on the campus server shall be set up by the BAS vendor. Jump tags and/or hyperlinks shall be set up to allow meter shop personnel to jump between historical data and graphic displaying live data.
 - a. Graphics for each meter shall be intuitive, easy to use and shall display all data read from the meter to allow the Meter Shop to easily verify proper communications between the meter and BAS system.

- b. Chiller Plant Metering. Each chiller plant shall have a Coefficient of Performance (COP) Graphic that sums BTU Metering and Electrical Usage and calculates instantaneous and totalized COP.
 - c. Major SCUB System KWH data shall be required from all Chillers, CHWP, CWP & Cooling Towers for this COP calculation.
 - d. The following are required inputs for the BAS System for each building.
 - 1) Electrical Meters for all Service Entries.
 - 2) Sub-Electrical Meters for various building entities (SCUB, Dining Services, Campus Rec, Residential Facilities, Etc.)
 - 3) Water Meters
 - 4) BTU Meters (Chilled Water, Heating Hot Water, Domestic Hot Water if exported)
 - 5) Steam Meters
 - 6) Natural Gas Meters for applicable systems as identified by the Environmental Compliance Office
- O. Laboratory CCMS Installation:
- 1. Air volumes within Biological Science Labs (BSL) should be constant volume (CV).
 - 2. Air valve selection and application for laboratory spaces:
 - a. Basis of design shall be medium pressure Venturi valve by Phoenix Controls. Design criteria shall consider valves orientation (horizontal, vertical).
 - 1) Controls Subcontractor to provide support for calibration of terminal units along with factory trained representative. Refer to Division 23 Section Testing and Balancing.
 - b. Labs built with a fume hood(s) shall use high speed Venturi valves throughout the lab space so that zone pressurization can be maintained for all conditions.
 - c. In ab pressure zones, standard VAV terminal units shall not be mixed with Venturi valves types so that zone pressurization is maintained consistently across the air volume range.
 - d. Low speed Venturi Valve control may be used in non-hood tracking pair applications.
 - 3. Direct flow sensing of air stream not acceptable. Indirect 0- 10 VDC control voltage to air volume scaling shall be basis of design. Typical scales of 200 cfm per volt however proper valve sizing and scaling shall be determined from design scope room air valve schedule.

4. BAS controls contractors zone controller shall be freely programmable and associated control program shall fully accessible from the CCMS BAS
5. BAS Sensors shall not be located in contaminated air streams.
6. Passive occupancy sensor technology to be used in animal labs.
7. BAS controls contractors zone controller shall be freely programmable and associated control program shall fully accessible from the CCMS BAS.
8. The BAS zone controller shall modulate the supply and general exhaust air valves, all other air valves shall be controlled locally and provide volume feedback (CFM/volt) back to the BAS Zone Controller.
9. Where Lab safety levels are specified the occupancy sensor shall be the point used to index specified ACH. Lab design rating shall determine ACH rate.

Laboratory Safety Level (LSL)	Occupied Min ACH	Un-occupied Min ACH
LSL-1	4	2
LSL-2	6	3
LSL-3	8	4
LSL-4	8	8
Chemical storage room	6	6

P. Accessibility:

1. As much as practical, design the system to keep the BAS equipment out of, and above user areas. The maintenance staff must have quick and direct access with sufficient room for operation and maintenance. Keep equipment out of elevated and/or enclosed spaces. Provide suitable access panels or doors only when this is not practical. The access panels or doors shall be a minimum size of 18 x18 inches

Q. Support products, tubing, piping wiring and raceways. Brace products to prevent lateral movement and sway or a break in attachment when subjected to a 25 pound force.

R. If codes and referenced standards are more stringent than requirements indicated, comply with requirements in codes and referenced standards.

S. Fabricate openings and install sleeves in ceilings, floors, roof, and walls required by installation of products. Before proceeding with drilling, punching, and cutting, check for concealed work to avoid damage. Patch, flash, grout, seal, and refinish openings to match adjacent condition.

T. Firestop Penetrations Made in Fire-Rated Assemblies: Comply with requirements in Section 078413 "Penetration Firestopping."

- U. Seal penetrations made in acoustically rated assemblies. Comply with requirements in Section 079200 "Joint Sealants."
- V. Welding Requirements:
 - 1. Restrict welding and burning to supports and bracing.
 - 2. No equipment shall be cut or welded without approval. Welding or cutting will not be approved if there is risk of damage to adjacent Work.
 - 3. Welding, where approved, shall be by inert-gas electric arc process and shall be performed by qualified welders according to applicable welding codes.
 - 4. If requested on-site, show satisfactory evidence of welder certificates indicating ability to perform welding work intended.
- W. Fastening Hardware:
 - 1. Stillson wrenches, pliers, and other tools that damage surfaces of rods, nuts, and other parts are prohibited for work of assembling and tightening fasteners.
 - 2. Tighten bolts and nuts firmly and uniformly. Do not overstress threads by excessive force or by oversized wrenches.
 - 3. Lubricate threads of bolts, nuts and screws with graphite and oil before assembly.
- X. If product locations are not indicated, install products in locations that are accessible and that will permit service and maintenance from floor, equipment platforms, or catwalks without removal of permanently installed furniture and equipment.
- Y. Corrosive Environments:
 - 1. Avoid or limit use of materials in corrosive airstreams and environments, including, but not limited to, the following:
 - a. Laboratory exhaust-air streams.
 - b. Process exhaust-air streams.
 - 2. When conduit is in contact with a corrosive airstream and environment, use Type 316 stainless-steel conduit and fittings or conduit and fittings that are coated with a corrosive-resistant coating that is suitable for environment. Comply with requirements for installation of raceways and boxes specified in Section 260533 "Raceways and Boxes for Electrical Systems."
 - 3. Where instruments are located in a corrosive airstream and are not corrosive resistant from manufacturer, field install products in NEMA 250, Type 4X enclosure constructed of Type 316L stainless steel.
- Z. Variable Volume Terminal Unit Emergency Demand Response Sequence of Operations:

1. The BAS system shall be programmed to include three building wide global/group demand limiting command levels to allow the CCMS operator, with administrator password access, to manually initiate the demand limiting sequence. The sequence shall be written to allow for additional logic thus allowing automatic level indexing in addition to manual user intervention.

AA. Variable Speed Drives (VFD) Monitoring and Control:

1. All VFDs' shall be monitored by the building automation system by an industry standard integration protocols (BACnet or Modbus).
2. All points necessary for the primary automated control functions of a VFD shall be hardwired to the building automation local controller.
3. The VFD hard wired points shall include the following points:
 - a. Run Status – Digital Input
 - b. Run Command – Digital Input
 - c. Speed Control – Analog Output
4. All Safeties shall be hardwired through the VFD safety circuit and shall stop the VFD controlled motor whenever drive is in the Bypass, Hand, or Auto state Disconnects for VFD Driven motors are to be hardwired into the VFD monitoring circuit.
5. All VFD Relays with pilot light indicators shall be mounted separately from VFD in a junction box with flexible conduit within 3 feed of VFD.
 - a. No disconnects to be installed between VFD and motor
 - b. If application requires a local disconnect a safety interlock conduit and wiring must be installed to disable VFD
 - c. Any motor application shall use current transducer (amps) on load side.
 - d. Software will be utilized to switch lead / lag.

BB. Chiller Plant Monitoring and Control

1. All associated primary pumps and isolation valves shall be hardwired interlocked to allow chiller operation by the unit's local control panel start switch.
2. All monitoring and control points shall be mapped into the building automation system by an industry standard integration protocols (BACnet or Modbus).
3. Provide chiller plant dash board that reflects the status of the chillers, pumps (and cooling towers as applicable) along with the integration of the kW readings from the pump VFD's and chiller to generate a plant COP to trend and display. The CCMS Engineer shall

reference ASHRAE Guideline 22 for integration of the chiller plant dash board and UMD can provide screen shots of other implementations on campus upon request.

CC. AHU Safeties

1. All AHU safeties and associated controls shall be hard wired with manual reset whether the system is locally or remotely controlled and/or manually overridden for constant or variable speed fans. Redundant automation controls applications shall emulate all hardwired safeties sequences. Do not include latching logic.
2. General: All AHU safeties shall be hard wired and shall override any local or remote control commands.
 - a. Normally-Open (NO): Contacts connect the circuit when the associated relay is activated; the circuit is disconnected when the associated relay is inactive (or loss of power).
 - b. Normally-Closed (NC): Contacts disconnect the circuit when the associated relay is activated; the circuit is connected when the associated relay is inactive (or loss of power). Contacts are shown in their Normal state.
 - c. On power loss the energized normally open pilot relay contacts shall open safety circuit placing the system into fail safe condition
3. All safety circuits shall be wired in series. The following safeties devices may be included in the safety circuit:
 - a. Smoke Detection
 - b. High / Low Static
 - c. Freeze Protection (see next section)
4. The unit smoke detector, when tripped, will stop the supply and return fans. The minimum outside air dampers, economizer dampers, and relief dampers will close and return air dampers shall open.
5. The High/Low Static pressure safeties installation shall follow manufacturer's installation guidelines. Specifically, mounting orientation shall be observed and location of reset shall be accessible without the use of a ladder.
6. AHU's that are interlocked to Laboratory exhaust fans. The laboratory exhaust fan shall utilize a normally closed relay (so that it has to be powered open to de-energize the fan). The sequence shall establish exhaust airflow prior to the start of the supply fans. In the event of the loss of a supply fan(s) the exhaust system shall continue to operate to maintain the static pressure set point in the exhaust ductwork. In the event of a loss of an exhaust fan(s) the supply shall track to the offset as required.

DD. AHU Safeties – Freeze Stat sequences:

1. Freeze Stat Safety Circuit: Freeze protection shall be required whenever there is a possibility of freezing the AHU water coils due to the exposure to outside air conditions.
2. General: The unit freezestat, when tripped, will stop the supply and return fans. The minimum outside air dampers, economizer dampers, and relief dampers will close. The return air dampers shall open and the hot water coil pump motor shall be energized.
 - a. The preheat water valve shall modulate as required to maintain the preheat coil leaving air temperature low limit set point (45°F) and the chilled water valve shall fully open.
 - b. The freeze alarm condition shall override all other automation system valve commands.
 - c. Freeze stat length shall, at minimum, be 1 linear foot per square foot of coil cross sectional area. Freeze stat installation shall follow manufacture installation guidelines. Freeze stat local trip setpoint shall be 36°F
3. When freeze circuit opens the following shall occur through automation:
 - a. The Preheat Water Coil PID control loop shall be enabled allowing the associated valve to modulate as required to maintain the Preheat Coil Leaving Air Temperature low limit set point (45F). Preheat Water Valve shall modulate open whenever the Mixed Air Temperature falls low limit set point (40F).
 - b. Command all other AHU water valves fully open. Do not command steam valves open.
 - c. All life safeties shall be hard wired and function according to the specified sequences whether the system is locally or remotely controlled and/or manually overridden.
 - d. All other safeties may be defined in the unit controller programming logic using BACnet priority array priority level 5, Critical Equipment Control, to perform the specified sequence whether the system is locally or remotely controlled and/or manually overridden.
 - e. Whenever Condensate Overflow Switch alarm is present then the programming logic shall (stop the associated fan(s) in 100% OA unit only), close outside air damper, close any associated water valve(s), and send alarm to CCMS. Condensate alarm shall take priority over freeze alarm condition requirement
4. Mixed Outside Air-AHU freeze safety circuit Mixed outside Air units freeze safety are to be based on a manual reset freezestat.
 - a. Upon detection of a freeze condition, the manual reset freezestat contacts shall open and immediately open the safety circuit. When freeze circuit opens the following shall occur through hardwired interlocks: Stop the supply and return fans Spring close the minimum outside air, economizer and relief dampers Spring open the return damper De-energize NC control relay to start the hot water coil pump motor

5. 100% Outside Air - AHU freeze safety circuit 100% OA units freeze safety are to be based on an auto reset freezestat wired into a timed delay relay (TDR) panel mounted reset and exterior mounted LED lamp indicating an alarm condition.
 - a. Upon detection of a freeze condition, the automatic reset freezestat contacts shall open and initiate the timer of the TDR. Whenever the alarm condition exceeds the TDR time delay setpoint (2 minutes, adjustable) the associated contacts shall open the safety circuit.
 - b. When freeze circuit opens the following shall occur through hardwired interlocks: Stop the supply fan Spring close the outside air damper De-energize NC control relay to start hot water coil pump motor.
 - c. When freeze circuit opens the following shall occur through automation: The preheat water coil PID control loop shall be enabled allowing the associated valve to modulate as required to maintain the preheat coil leaving air temperature low limit set point (45F) Command all other non-steam valves fully open. When Condensate Overflow Switch is present then associated non-steam valve shall close.

EE. Static Pressure Transmitter

1. Supply or exhaust duct mounted static pressure transmitters, with LCD display, shall be mounted in the associated AHU automation control panel.
2. The device shall be configurable for multi-range, 24vac power and voltage signal, 3 or 4 wire transmitters. Do not use 4-20 ma signal
3. Pressure probe sensing locations shall be identified on automation control floor drawings and included in graphical user interface flow diagram representation.
4. The duct static pressure probe shall be installed approximately 2/3 of the way down the duct main trunk. Pressure probe sensing locations shall be identified on automation control floor drawings and included in graphical user interface representation.
5. Basis of Design: Veris PX series

FF. VAV Terminal Units

1. VAV terminal units shall include discharge air temperature sensor downstream of the reheat coil (not required for cooling only VAV's).

GG. Fan Coil Unit

1. Each FCU shall be provided with an auxiliary drain pan. This pan shall have a moisture sensor that sends a critical alarm to the CCMS system. Upon detection of moisture the chilled water shall close and the fan shall continue to operate.

HH. Fume Hoods

1. Each fume hood shall have a face velocity monitor. Power for the fume hood face velocity monitor shall come from the fume hood, tapped in from the fume hood's electrical outlet.

II. Global Points

1. Process variable inputs of Proportional Integral & Derivative Control loops shall be a hardwired input type wired directly into the associated controller. Process variable input values shall not be delivered across the controller network.

3.5 CONTROLLER INSTALLATION

- A. Install controllers in enclosures to comply with indicated requirements – All Controllers shall be mounted directly onto panel backplane. Stacking controllers is unacceptable.
- B. When installing components in the controllers a minimum of 25% spare points shall be available in each controller (the 25% should be balanced between inputs and outputs). New controllers installed for renovations on campus shall match or integrate seamlessly with the existing control installation.
- C. Connect controllers to field power supply and to UPS units where indicated.
- D. Install controller with latest version of applicable software and configure to execute requirements indicated.
- E. Test and adjust controllers to verify operation of connected I/O to achieve performance indicated requirements while executing sequences of operation.
- F. Installation of Network Controllers:
 1. Quantity and location of network controllers shall be determined by DDC system manufacturer to satisfy requirements indicated.
 2. Install controllers in a protected location that is easily accessible by operators.
 3. Top of controller shall be within 72 inches of finished floor.
- G. Installation of Programmable Application Controllers:
 1. Quantity and location of programmable application controllers shall be determined by DDC system manufacturer to satisfy requirements indicated.
 2. Install controllers in a protected location that is easily accessible by operators.
 3. Top of controller shall be within 72 inches of finished floor.
- H. Application-Specific Controllers:
 1. Quantity and location of application-specific controllers shall be determined by DDC system manufacturer to satisfy requirements indicated.

2. For controllers not mounted directly on equipment being controlled, install controllers in a protected location that is easily accessible by operators.

3.6 ENCLOSURES INSTALLATION

- A. All BAS controllers shall be housed in a Control Panel Enclosure, mounted directly onto panel backplane where stacking controllers is unacceptable. All Enclosures shall include:
 1. Terminal strips with numbers.
 2. Twenty percent (10%) of free space for future expansion of the system for each type of point (AO, AI, BO, BI).
 3. Hinged door with latch handle.
 4. Back plate firmly secured and grounded to the enclosure.
 5. Attach laminated control drawings, minimum 11 x 17, on the inside of the panel door.
 6. Label Power source and breaker circuit number.
 7. All control panels shall be identified by an exterior tag, consistent with identification within the ATC O&M Manual, secured on the exterior upper left hand corner.
- B. All panels shall include laminated wiring diagram including details of terminations, modules, relays, switches, reset and push buttons, indicating lights, inputs and outputs, power supplies and network connections
- C. Control panel supply voltage shall not exceed industry standard 24 VAC and clearly identify fuse wiring, type, terminations and rating. Voltages greater than 24 VAC shall not be exposed within the control panel. An associated electrical trough shall be installed for any panel enclosures greater than 16 inches wide. Label panel with associated circuit panel source.
- D. Install the following items in enclosures, to comply with indicated requirements:
 1. Gateways.
 2. Routers.
 3. Controllers.
 4. Electrical power devices.
 5. UPS units.
 6. Relays.
 7. Accessories.

8. Instruments.
 9. Actuators
- E. Attach wall-mounted enclosures to wall using the following types of steel struts:
1. For NEMA 250, Type 1 Enclosures: Use galvanized steel strut and hardware.
 2. For NEMA 250, Type 4 Enclosures and Enclosures Located Outdoors: Use stainless-steel strut and hardware.
 3. Install plastic caps on exposed cut edges of strut.
- F. Align bottom of adjacent enclosures.
- G. Install floor-mounted enclosures located in mechanical equipment rooms on concrete housekeeping pads. Attach enclosure legs using galvanized steel anchors.
- H. Install continuous and fully accessible wireways to connect conduit, wire, and cable to multiple adjacent enclosures. Wireway used for application shall have protection equal to NEMA 250 rating of connected enclosures.

3.7 ELECTRIC POWER CONNECTIONS

- A. Connect electrical power to DDC system products requiring electrical power connections.
- B. Design of electrical power to products not indicated with electric power is delegated to DDC system provider and installing trade. Work shall comply with NFPA 70 and other requirements indicated.
- C. Comply with requirements in Division 26 Section "Enclosed Switches and Circuit Breakers" for electrical power circuit breakers.
- D. Comply with requirements in Division 26 Section "Low-Voltage Electrical Power Conductors and Cables" for electrical power conductors and cables.
- E. Comply with requirements in Division 26 Section "Raceways and Boxes for Electrical Systems" for electrical power raceways and boxes.

3.8 IDENTIFICATION

- A. Identify system components, wiring, cabling, and terminals. Comply with requirements in Section 260553 "Identification for Electrical Systems" for identification products and installation.
- B. Install self-adhesive labels with unique identification on face for each of the following:
 1. Operator workstation.

2. Server.
 3. Gateway.
 4. Router.
 5. Protocol analyzer.
 6. DDC controller.
 7. Enclosure.
 8. Electrical power device.
 9. UPS unit.
 10. Accessory.
- C. Install unique instrument identification on face of each instrument connected to a DDC controller.
- D. Install unique identification on face of each control damper and valve actuator connected to a DDC controller.
- E. Where product is installed above accessible tile ceiling, also install matching identification on face of ceiling grid located directly below.
- F. Where product is installed above an inaccessible ceiling, also install identification on face of access door directly below.
- G. Warning Labels and Signs:
1. Shall be permanently attached to equipment that can be automatically started by DDC control system.
 2. Shall be located in a highly visible location near power service entry points.

3.9 EQUIPMENT NOMENCLATURE AND NUMBERING

- A. To avoid duplication with existing mechanical equipment ID numbers, for all renovation or addition designs to existing buildings, the designation numbers assigned to mechanical equipment such as AHUs, Pumps, Chillers, Exhaust Fans, etc., shall be coordinated with the campus building automation group which is part of the HVAC Department. The numbers assigned to new equipment shall be consistent throughout all drawings and documentation.
- B. The BAS contractor shall follow the following naming convention:
1. Unit type-Building Number-Floor-Unit Number

2. Where Unit Type: (AHU=Air Handler Unit, EF=Exhaust Fan, CH= Chiller, CT= Cooling Tower, CHWP= Chilled Water Pump, CWP= Condenser Water Pump, FCU= Fan Coil Unit, VAV= Variable Air Volume)
3. Example, AHU-077-02-04 represents AHU#4 in building 077, located on the second floor.
4. If the contract drawings do not conform to this format, please contact the CCMS operations supervisor (301-405-3244) for clarifications.

C. Major equipment (Chillers, Cooling Towers, Pumps, Air Handling Units, Air Compressors, etc. shall be abbreviated with a 2 to 4 letter identifier, followed by building number, followed by the floor it is located on, followed by an I.D. number. Examples Include:

1. AHU- 077-02-03 – Air Handling Unit-Building 077-Second Floor–Unit ID Number 03
2. CT- 415-0R-04 – Cooling Tower – Building 415 – Roof – Unit ID Number 04
3. CWP-003-0B-01 – Chilled Water Pump – Building 003 – Basement – Unit ID 01
4. Reference tables below for UMD Equipment and Floor abbreviations:

<u>Equipment</u>	<u>Abbreviation</u>
<u>Air Handling Unit</u>	<u>AHU</u>
<u>Water Cooled Chiller</u>	<u>CH</u>
<u>Air Cooled Chiller</u>	<u>ACC</u>
<u>Cooling Tower</u>	<u>CT</u>
<u>Chilled Water Pump</u>	<u>CHWP</u>
<u>Condenser Water Pump</u>	<u>CDWP</u>
<u>Packaged Rooftop Unit</u>	<u>RTU</u>

<u>Floor</u>	<u>Floor ID</u>
<u>Sub-Basement</u>	<u>SB</u>
<u>Basement</u>	<u>0B</u>
<u>Ground Floor</u>	<u>00</u>
<u>First Floor</u>	<u>01</u>
<u>Second Floor</u>	<u>02</u>
<u>Third Floor</u>	<u>03</u>
<u>Roof</u>	<u>0R</u>

3.10 NETWORK NAMING AND NUMBERING

- A. Coordinate with Owner and provide unique naming and addressing for networks and devices.

B. BACnet over Campus IP Addressing:

1. System Addressing: Each BACnet Device Object Instance on an Intra-network has to be exclusive for each device.
2. CCMS contractors shall conform to the following BACnet Network and Device Instance numbering format scheme, based on Cornell model as described in the Nov 2007 ASHRAE Journal, where after reviewing the controls submittal and validating the network architecture for a given project the university would then allocate a range of BACnet Network Numbers and Device Instance Numbers based on the following.
3. T format for the Network Number is SFFFN where the following applies:
4. S=Site (1=Main Campus, 2=Main Campus Extended Network, 3= Main Campus Extended Network or Off Campus)
5. FFF= Facility (Building) Number (Always 3 digits – range 000-999)
6. N=Network Number (Always 1 digit - range 0-9). The format for the Device Instance Number is SFFFNDD where DD=Device Number (Always 2 digits - range 00-99)

<u>Network Numbers:</u>	<u>Provided By UMD</u>
<u>Building Number:</u>	<u>Provided By UMD</u>
<u>Device Number:</u>	<u>Defined by Vendor</u>

7. CCMS group is responsible for maintaining master allocation list.
8. Whenever S=1 and either the N or DD range have been exceeded we recommend continuing the numbering scheme using S=2.
9. Note that the contractors' strict adherence to the format, SFFFN and SFFFNDD, is required in order to prevent potential conflicts in the numbering scheme.

3.11 CONTROL WIRE, CABLE AND RACEWAYS INSTALLATION

- A. Comply with NECA 1.
- B. Control vendor shall conform to UMD CCMS internal wire color standards and codes. See Wiring Section below. All wiring shall be stranded copper, twisted pairs with shield insulated for compliance with National Electric Code including requirements when control wires are run in high voltage panels. Solid Wires are not acceptable. Use wire Stacon for all screw type terminations. All sensing and control wiring shields shall be grounded at the BAS control panel only.
- C. Color code of wiring inside BAS Control panel:
 1. Red - 24vac power
 2. Black - 24vac common and input/outputs common

3. White - input signal wire
4. Orange - analog output signal wire
5. Blue - digital output from controller
6. Purple - output from relays inside of panel
7. Green - ground
8. Yellow - 24vdc positive
9. Brown - 24vdc negative
10. Jacket Color code of communication wiring inside BAS Control panel:
 - a. Blue - Bacnet MSTP
 - b. Green - Arcnet
 - c. Yellow - Modbus MSTP
 - d. Red - (Cat5/6) CCMS own IP building network and IP controllers

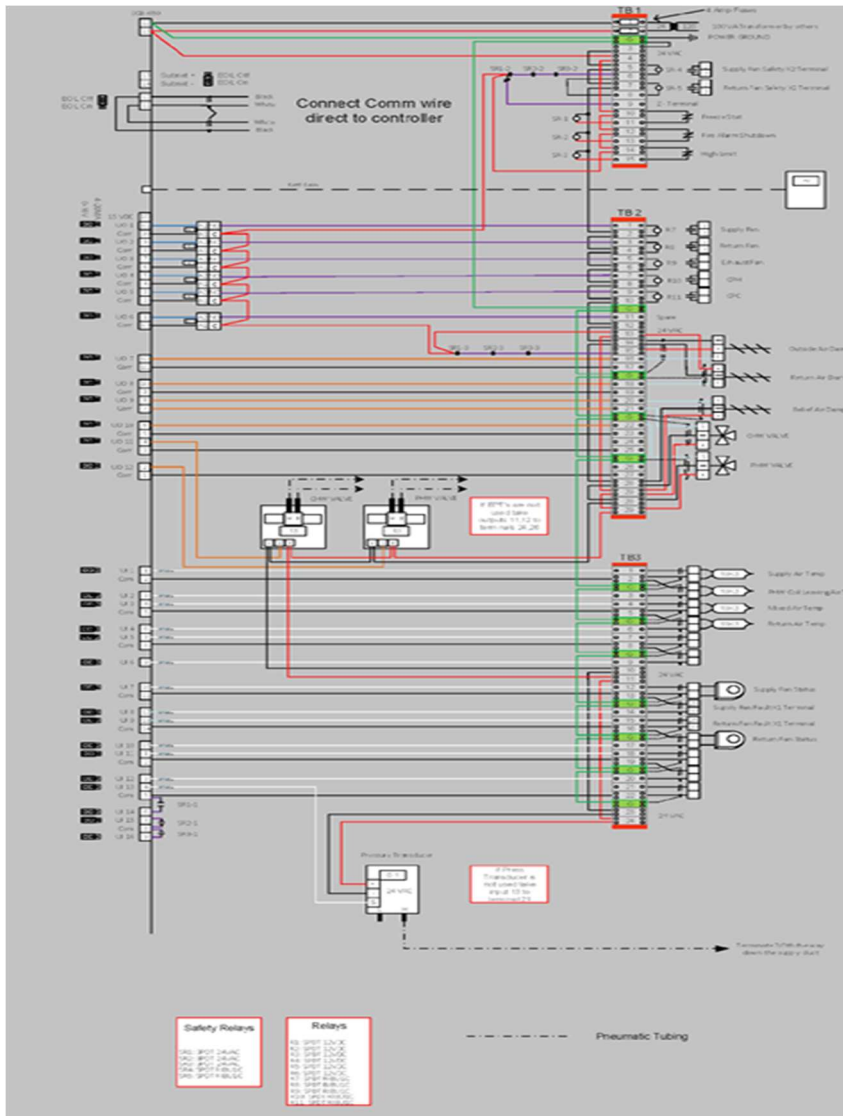

Figure Section 3.12 B

D. Wire and Cable Installation:

1. Comply with installation requirements in Division 26 Section "Low-Voltage Electrical Power Conductors and Cables."
2. Install cables with protective sheathing that is waterproof and capable of withstanding continuous temperatures of 90 deg C with no measurable effect on physical and electrical properties of cable.
 - a. Provide shielding to prevent interference and distortion from adjacent cables and equipment.
3. Terminate wiring in a junction box.

- a. Clamp cable over jacket in junction box.
 - b. Individual conductors in the striped section of the cable shall be slack between the clamping point and terminal block.
 4. Terminate field wiring and cable not directly connected to instruments and control devices having integral wiring terminals using terminal blocks.
 5. Install signal transmission components according to IEEE C2, REA Form 511a, NFPA 70, and as indicated.
 6. Use shielded cable to transmitters.
 7. Use shielded cable to temperature sensors.
 8. Perform continuity and megger testing on wire and cable after installation.
- E. Conduit Installation:
1. Comply with Section "260533 "Raceways and Boxes for Electrical Systems" for control-voltage conductors.
 2. Comply with Section 270528 "Pathways for Communications Systems" for balanced twisted pair cabling and optical fiber installation.
 3. Green conduit for BAS $\frac{3}{4}$ minimum size.

3.12 FIELD QUALITY CONTROL

- A. Testing Agency: Engage a qualified testing agency to perform tests and inspections.
- B. Manufacturer's Field Service: Engage a factory-authorized service representative to test and inspect components, assemblies, and installations, including connections.
- C. Perform the following tests and inspections:
 1. Perform each visual and mechanical inspection and electrical test stated in NETA Acceptance Testing Specification. Certify compliance with test parameters.
 2. Test and adjust controls and safeties. Replace damaged and malfunctioning controls and equipment.
 3. Testing of Pneumatic and Air-Signal Tubing:
 - a. Test for leaks and obstructions.
 - b. Disconnect each pipe and tubing line before a test is performed, and blowout dust, dirt, trash, condensate and other foreign materials with compressed air. Use

commercially pure compressed air or nitrogen as distributed in gas cylinders. Air from an oil-free compressor with an air dryer is an acceptable alternative for the test.

- c. After foreign matter is expelled and line is free from obstructions, plug far end of tubing run.
- d. Connect a pressure source to near end of run with a needle valve between air supply and tubing run.
- e. Connect a pressure gage accurate to within 0.5 percent of test between the shutoff needle valve and tubing run under test.
- f. For system pressures above 30 psig apply a pressure of 1.5 times operating pressure. Record pressure in tubing run every 10 minutes for one hour. Allowable drop in pressure in one-hour period shall not exceed 1 psig.
- g. For system pressures 30 psig and below, apply a pressure of 2.0 times operating pressure to piping and tubing run. Record pressure in tubing run every 5 minutes for one hour. Allowable drop in pressure in one-hour period shall not exceed 0.5 psig.

D. Testing:

1. Perform preinstallation, in-progress, and final tests, supplemented by additional tests, as necessary.
2. Preinstallation Cable Verification: Verify integrity and serviceability for new cable lengths before installation. This assurance may be provided by using vendor verification documents, testing, or other methods. As a minimum, furnish evidence of verification for cable attenuation and bandwidth parameters.
3. In-Progress Testing: Perform standard tests for correct pair identification and termination during installation to ensure proper installation and cable placement. Perform tests in addition to those specified if there is any reason to question condition of material furnished and installed. Testing accomplished is to be documented by agency conducting tests. Submit test results for Project record.
4. Final Testing: Perform final test of installed system to demonstrate acceptability as installed. Testing shall be performed according to a test plan supplied by DDC system manufacturer. Defective Work or material shall be corrected and retested. As a minimum, final testing for cable system, including spare cable, shall verify conformance of attenuation, length, and bandwidth parameters with performance indicated.
5. Test Equipment: Use an optical fiber time domain reflectometer for testing of length and optical connectivity.
6. Test Results: Record test results and submit copy of test results for Project record.

3.13 DDC SYSTEM I/O CHECKOUT PROCEDURES

- A. Check installed products before continuity tests, leak tests and calibration.
- B. Check instruments for proper location and accessibility.
- C. Check instruments for proper installation on direction of flow, elevation, orientation, insertion depth, or other applicable considerations that will impact performance.
- D. Check instrument tubing for proper isolation, fittings, slope, dirt legs, drains, material and support.
- E. For pneumatic products, verify that air supply for each product is properly installed.
- F. Control Damper Checkout:
 - 1. For pneumatic dampers, verify that pressure gages are provided in each airline to the damper actuator and positioner.
 - 2. Verify that control dampers are installed correctly for flow direction.
 - 3. Verify that proper blade alignment, either parallel or opposed, has been provided.
 - 4. Verify that damper frame attachment is properly secured and sealed.
 - 5. Verify that the damper actuator and linkage attachment is secure.
 - 6. Verify that actuator wiring is complete, enclosed and connected to the correct power source.
 - 7. Verify that damper blade travel is unobstructed.
- G. Control Valve Checkout:
 - 1. For pneumatic valves, verify that pressure gages are provided in each air line to valve actuator and positioner.
 - 2. Verify that control valves are installed correctly for flow direction.
 - 3. Verify that valve body attachment is properly secured and sealed.
 - 4. Verify that valve actuator and linkage attachment is secure.
 - 5. Verify that actuator wiring is complete, enclosed and connected to correct power source.
 - 6. Verify that valve ball, disc or plug travel is unobstructed.
 - 7. After piping systems have been tested and put into service, but before insulating and balancing, inspect each valve for leaks. Adjust or replace packing to stop leaks. Replace the valve if leaks persist.

H. Instrument Checkout:

1. Verify that the instrument is correctly installed for location, orientation, direction and operating clearances.
2. Verify that attachment is properly secured and sealed.
3. Verify that conduit connections are properly secured and sealed.
4. Verify that wiring is properly labeled with unique identification, correct type and size and is securely attached to proper terminals.
5. Inspect instrument tag against approved submittal.
6. For instruments with tubing connections, verify that tubing attachment is secure and isolation valves have been provided.
7. For flow instruments, verify that recommended upstream and downstream distances have been maintained.
8. For temperature instruments:
 - a. Verify sensing element type and proper material.
 - b. Verify length and insertion.

3.14 DDC SYSTEM I/O ADJUSTMENT, CALIBRATION AND TESTING:

- A. Calibrate each instrument installed that is not factory calibrated and provided with calibration documentation.
- B. Provide a written description of proposed field procedures and equipment for calibrating each type of instrument. Submit procedures before calibration and adjustment.
- C. For each analog instrument, make a three-point test of calibration for both linearity and accuracy.
- D. Equipment and procedures used for calibration shall comply with instrument manufacturer's written instructions.
- E. Provide diagnostic and test equipment for calibration and adjustment.
- F. Field instruments and equipment used to test and calibrate installed instruments shall have accuracy at least twice the instrument accuracy being calibrated. An installed instrument with an accuracy of 1 percent shall be checked by an instrument with an accuracy of 0.5 percent.
- G. Calibrate each instrument according to the instrument instruction manual supplied by the manufacturer.

- H. If after calibration indicated performance cannot be achieved, replace out-of-tolerance instruments.
- I. Comply with field testing requirements and procedures indicated by ASHRAE's Guideline 11, "Field Testing of HVAC Control Components," in the absence of specific requirements, and to supplement requirements indicated.
- J. Analog Signals:
 - 1. Check analog voltage signals using a precision voltage meter at zero, 50, and 100 percent.
 - 2. Check analog current signals using a precision current meter at zero, 50, and 100 percent.
 - 3. Check resistance signals for temperature sensors at zero, 50, and 100 percent of operating span using a precision-resistant source.
- K. Digital Signals:
 - 1. Check digital signals using a jumper wire.
 - 2. Check digital signals using an ohmmeter to test for contact making or breaking.
- L. Control Dampers:
 - 1. Stroke and adjust control dampers following manufacturer's recommended procedure, from 100 percent open to 100 percent closed and back to 100 percent open.
 - 2. Stroke control dampers with pilot positioners. Adjust damper and positioner following manufacturer's recommended procedure, so damper is 100 percent closed, 50 percent closed and 100 percent open at proper air pressure.
 - 3. Check and document open and close cycle times for applications with a cycle time less than 30 seconds.
 - 4. For control dampers equipped with positive position indication, check feedback signal at multiple positions to confirm proper position indication.
- M. Control Valves:
 - 1. Stroke and adjust control valves following manufacturer's recommended procedure, from 100 percent open to 100 percent closed and back to 100 percent open.
 - 2. Stroke control valves with pilot positioners. Adjust valve and positioner following manufacturer's recommended procedure, so valve is 100 percent closed, 50 percent closed and 100 percent open at proper air pressures.
 - 3. Check and document open and close cycle times for applications with a cycle time less than 30 seconds.

4. For control valves equipped with positive position indication, check feedback signal at multiple positions to confirm proper position indication.
- N. Meters: Check sensors at zero, 50, and 100 percent of Project design values.
- O. Sensors: Check sensors at zero, 50, and 100 percent of Project design values.
- P. Switches: Calibrate switches to make or break contact at set points indicated.
- Q. Transmitters:
 1. Check and calibrate transmitters at zero, 50, and 100 percent of Project design values.
 2. Calibrate resistance temperature transmitters at zero, 50, and 100 percent of span using a precision-resistant source.

3.15 DDC CONTROLLER I/O CONTROL LOOP TESTS

- A. Testing:
 1. Test every I/O point connected to DDC controller to verify that safety and operating control set points are as indicated and as required to operate controlled system safely and at optimum performance.
 2. Test every I/O point throughout its full operating range.
 3. Test every control loop to verify operation is stable and accurate.
 4. Adjust control loop proportional, integral and derivative settings to achieve optimum performance while complying with performance requirements indicated. Document testing of each control loop's precision and stability via trend logs.
 5. Test and adjust every control loop for proper operation according to sequence of operation.
 6. Test software and hardware interlocks for proper operation. Correct deficiencies.
 7. Operate each analog point at the following:
 - a. Upper quarter of range.
 - b. Lower quarter of range.
 - c. At midpoint of range.
 8. Exercise each binary point.
 9. For every I/O point in DDC system, read and record each value at operator workstation, at DDC controller and at field instrument simultaneously. Value displayed at operator workstation, at DDC controller and at field instrument shall match.

10. Prepare and submit a report documenting results for each I/O point in DDC system and include in each I/O point a description of corrective measures and adjustments made to achieve desired results.

3.16 DDC SYSTEM VALIDATION TESTS

- A. Perform validation tests before requesting final review of system. Before beginning testing, first submit a Pretest Checklist and Test Plan.
- B. After testing is complete, submit completed test checklist.
- C. Pretest Checklist: Submit the following list with items checked off once verified:
 1. Detailed explanation for any items that are not completed or verified.
 2. Required mechanical installation work is successfully completed and HVAC equipment is working correctly.
 3. HVAC equipment motors operate below full-load amperage ratings.
 4. Required DDC system components, wiring, and accessories are installed.
 5. Installed DDC system architecture matches approved Drawings.
 6. Control electric power circuits operate at proper voltage and are free from faults.
 7. Required surge protection is installed.
 8. DDC system network communications function properly, including uploading and downloading programming changes.
 9. Using BACnet protocol analyzer, verify that communications are error free.
 10. Each controller's programming is backed up.
 11. Equipment, products, tubing, wiring cable and conduits are properly labeled.
 12. All I/O points are programmed into controllers.
 13. Testing, adjusting and balancing work affecting controls is complete.
 14. Dampers and actuators zero and span adjustments are set properly.
 15. Each control damper and actuator goes to failed position on loss of power.
 16. Valves and actuators zero and span adjustments are set properly.
 17. Each control valve and actuator goes to failed position on loss of power.

18. Meter, sensor and transmitter readings are accurate and calibrated.
19. Control loops are tuned for smooth and stable operation.
20. View trend data where applicable.
21. Each controller works properly in standalone mode.
22. Safety controls and devices function properly.
23. Interfaces with fire-alarm system function properly.
24. Electrical interlocks function properly.
25. Operator workstations and other interfaces are delivered, all system and database software is installed, and graphic are created.
26. Record Drawings are completed.

D. Test Plan:

1. Prepare and submit a validation test plan including test procedures for performance validation tests.
2. Test plan shall address all specified functions of DDC system and sequences of operation.
3. Explain detailed actions and expected results to demonstrate compliance with requirements indicated.
4. Explain method for simulating necessary conditions of operation used to demonstrate performance.
5. Include a test checklist to be used to check and initial that each test has been successfully completed.
6. Submit test plan documentation 10 business days before start of tests.

E. Validation Test:

1. Verify operating performance of each I/O point in DDC system.
 - a. Verify analog I/O points at operating value.
 - b. Make adjustments to out-of-tolerance I/O points.
 - 1) Identify I/O points for future reference.
 - 2) Simulate abnormal conditions to demonstrate proper function of safety devices.

- 3) Replace instruments and controllers that cannot maintain performance indicated after adjustments.
2. Simulate conditions to demonstrate proper sequence of control.
3. Readjust settings to design values and observe ability of DDC system to establish desired conditions.
4. After 24 Hours following Initial Validation Test:
 - a. Re-check I/O points that required corrections during initial test.
 - b. Identify I/O points that still require additional correction and make corrections necessary to achieve desired results.
5. After 24 Hours of Second Validation Test:
 - a. Re-check I/O points that required corrections during second test.
 - b. Continue validation testing until I/O point is normal on two consecutive tests.
6. Completely check out, calibrate, and test all connected hardware and software to ensure that DDC system performs according to requirements indicated.
7. After validation testing is complete, prepare and submit a report indicating all I/O points that required correction and how many validation re-tests it took to pass. Identify adjustments made for each test and indicate instruments that were replaced.

3.17 EXTENDED OPERATION TEST

- A. Extended operation test is intended to simulate normal operation of DDC system by Owner.
- B. Operate DDC system for an operating period of 15 consecutive calendar days following Substantial Completion. Coordinate exact start date of testing with Owner.
 1. The Central Control and Monitoring System (CCMS) contractor shall formally notify the CCMS and HVAC group that the systems are ready for the 15 consecutive day test period once all of the project automation system controller and integrated input/output point data, control sequence, alarms and graphical programming have been downloaded, validated and tested.
 2. During the test period the CCMS contractor shall be responsible for maintain communications at all tiers as well as maintaining proper operation of the input sensors and controlled devices. Additionally, the CCMS contractor shall assure that all control logic and outputs remain in an automatic state.
 3. It shall be the responsibility of all contractors that the HVAC equipment within the building remains in an operational and automatic mode of operation (Chillers, Variable Frequency Drives, terminal units, and motorized valve and damper actuators, etc.)

4. Prior to the test period, the contractor shall be responsible for defining historical trend point information of all primary equipment status, temperature, volume, pressure, humidity, set points, controlled discrete and modulated variables points. During the test period the contractor shall be responsible for assuring trend data integrity. By default, Analog trend data points shall be defined using 15 minute interval and Binary trend data shall be defined as Change of State.
 5. During the test, if communication or sensory failure is detected (with the exception of the campus Ethernet system going off line) or the HVAC equipment fails to operate properly, the contractors shall be responsible for corrective action within 24 hours.
 6. If the operation of the building HVAC systems or CCMS communication is interrupted for a period of greater than 24 consecutive hours, the 15 day test will stop and will be started again from day one after corrective actions have been performed.
 7. At the conclusion of the 15 day period, the trend data, sequencing, alarming and graphical user interface shall be used to determine if the HVAC systems maintained building space conditions, functioned in accordance with the specified sequence and controlled the primary control variables in a stable and predictable manner.
 8. If this information shows numerous significant periods of time when HVAC was not operating properly or fails to maintain correct building conditions, the test will be declared a failure and must be repeated as required until the systems are demonstrated to operate properly for 15 consecutive days.
- C. Provide an operator familiar with DDC system installed to man an operator workstation during eight hours of each normal business day occurring during operating period.
- D. During operating period, DDC system shall demonstrate correct operation and accuracy of monitored and controlled points as well as operation capabilities of sequences, logs, trends, reports, specialized control algorithms, diagnostics, and other software indicated.
1. Correct defects of hardware and software when it occurs.
- E. Definition of Failures and Downtime during Operating Period:
1. Failed I/O point constituting downtime is an I/O point failing to perform its intended function consistently and a point physically failed due to hardware and software.
 2. Downtime is when any I/O point in DDC system is unable to fulfill its' required function.
 3. Downtime shall be calculated as elapsed time between a detected point failure as confirmed by an operator and time point is restored to service.
 4. Maximum time interval allowed between DDC system detection of failure occurrence and operator confirmation shall be 0.5 hours.
 5. Downtime shall be logged in hours to nearest 0.1 hour.

6. Power outages shall not count as downtime, but shall suspend test hours unless systems are provided with UPS and served through a backup power source.
 7. Hardware or software failures caused by power outages shall count as downtime.
- F. During operating period, log downtime and operational problems are encountered.
1. Identify source of problem.
 2. Provide written description of corrective action taken.
 3. Record duration of downtime.
 4. Maintain log showing the following:
 - a. Time of occurrence.
 - b. Description of each occurrence and pertinent written comments for reviewer to understand scope and extent of occurrence.
 - c. Downtime for each failed I/O point.
 - d. Running total of downtime and total time of I/O point after each problem has been restored.
 5. Log shall be available to Owner for review at any time.
- G. Prepare test and inspection reports.

3.18 DEMONSTRATION AND TRAINING

- A. System Demonstration of ATC system shall occur prior to final owner training. The contractor shall demonstrate, in a round table session with CCMS, system functionality and review primary control functions, graphical representation, and review of all associated links, in accordance with CCMS BAS O&M manual documentation. This round table shall be based on the final building automation submittal and the contractor shall provide copies of that submittal at the start of the session. The time Accrued to perform a successful demonstration shall be credited toward training hour requirement. A minimum of 8 hours should be estimated for the round table demonstration for any project (estimate minimum 24 hours .
- B. Engage a factory-authorized service representative with complete knowledge of Project-specific system installed to train Owner's maintenance personnel to adjust, operate, and maintain DDC system
- C. Extent of Training:
1. Base extent of training on scope and complexity of DDC system indicated and training requirements indicated. Provide extent of training required to satisfy requirements indicated even if more than minimum training requirements are indicated.

2. Inform Owner of anticipated training requirements if more than minimum training requirements are indicated.
3. Minimum Training Requirements:
 - a. Provide not less than two days of training total (in addition to the round table noted above).
 - b. Stagger training over multiple training classes to accommodate Owner's requirements. All training shall occur before end of warranty period.
 - c. Each training session shall be not less than three consecutive day(s).

D. Training Schedule:

1. Schedule training with Owner 15 business days before expected Substantial Completion.
2. Schedule training to provide Owner with at least 5 business days of notice in advance of training.
3. Training shall occur within normal business hours at a mutually agreed on time. Unless otherwise agreed to, training shall occur Monday through Friday, except on U.S. Federal holidays, with two morning sessions and two afternoon sessions. Each morning session and afternoon session shall be split in half with 15 minute break between sessions. Morning and afternoon sessions shall be separated by 60 minute lunch period. Training, including breaks and excluding lunch period, shall not exceed eight hours per day.
4. Provide staggered training schedule as requested by Owner.

E. Training Attendee List and Sign-in Sheet:

1. Request from Owner in advance of training a proposed attendee list with name, phone number and e-mail address.
2. Provide a preprinted sign-in sheet for each training session with proposed attendees listed and no fewer than six blank spaces to add additional attendees.
3. Preprinted sign-in sheet shall include training session number, date and time, instructor name, phone number and e-mail address, and brief description of content to be covered during session. List attendees with columns for name, phone number, e-mail address and a column for attendee signature or initials.
4. Circulate sign-in sheet at beginning of each session and solicit attendees to sign or initial in applicable location.
5. At end of each training day, send Owner an e-mail with an attachment of scanned copy (PDF) of circulated sign-in sheet for each session.

F. Training Attendee Headcount:

1. Plan in advance of training for five attendees.
2. Headcount may vary depending on training content covered in session. Attendee access may be restricted to some training content for purposes of maintaining system security.

G. Training Outline:

1. Submit training outline for Owner review at least 5 business day before scheduling training.
2. Outline shall include a detailed agenda for each training day that is broken down into each of four training sessions that day, training objectives for each training session and synopses for each lesson planned.

H. On-Site Training:

1. Owner will provide conditioned classroom or workspace with ample desks or tables, chairs, power and data connectivity for instructor and each attendee.
2. Instructor shall provide training materials, projector and other audiovisual equipment used in training.
3. Provide as much of training located on-site as deemed feasible and practical by Owner.
4. On-site training shall include regular walk-through tours, as required, to observe each unique product type installed with hands-on review of operation, calibration and service requirements.
5. Operator workstation provided with DDC system shall be used in training. If operator workstation is not indicated, provide a temporary workstation to convey training content.

END OF SECTION 230923

SECTION 230923.13 - ENERGY METERS

PART 1 - GENERAL

1.1 RELATED DOCUMENTS

- A. Drawings and general provisions of the Contract, including General and Supplementary Conditions and Division 01 Specification Sections, apply to this Section.

1.2 SUMMARY

- A. Section includes thermal and electric power energy meters that connect to DDC systems.
- B. Related Requirements:
 - 1. Section 230923 "Direct Digital Control (DDC) for HVAC" for control equipment and software, relays, electrical power devices, uninterruptible power supply units, wire, and cable.

1.3 DEFINITIONS

- A. DDC: Direct-digital control.
- B. Ethernet: Local area network based on IEEE 802.3.1 standards.
- C. Firmware: Software (programs or data) that has been written onto read-only memory (ROM). Firmware is a combination of software and hardware. Storage media with ROMs that have data or programs recorded on them are firmware.
- D. I/O: Input/output.
- E. RMS: Root-mean-square value of alternating voltage, which is the square root of the mean value of the square of the voltage values during a complete cycle.
- F. RS-232: A TIA standard for asynchronous serial data communications between terminal devices.
- G. RS-485: A TIA standard for multipoint communications using two twisted pairs.
- H. RTD: Resistance temperature detector.

1.4 ACTION SUBMITTALS

- A. Product Data: For each type of product, including the following:

1. Construction details, material descriptions, dimensions of individual components and profiles, and finishes.
2. Operating characteristics, electrical characteristics, and furnished accessories indicating electrical power requirements.
3. Product description with complete technical data, performance curves, and product specification sheets.

B. Shop Drawings:

1. Include plans, elevations, sections, and mounting details.
2. Include details of product assemblies. Indicate dimensions, weights, loads, required clearances, method of field assembly, components, and location and size of each field connection.
3. Include diagrams for power, signal, and control wiring.

1.5 INFORMATIONAL SUBMITTALS

- A. Product Certificates: For each product requiring a certificate.

1.6 CLOSEOUT SUBMITTALS

- A. Operation and Maintenance Data: For energy meters to include in operation and maintenance manuals.
- B. CCMS interconnect submittal indicating communication protocol and point naming convention to be reviewed by UMD Engineering & Energy and UMD CCMS.

PART 2 - PRODUCTS

2.1 THERMAL ENERGY METERS

- A. Real time meter data is a required input to the BAS System. The meter data is compared with building occupancy and comfort levels and is an input to the CCMS Building Automation System (BAS) for Demand Shedding.
- B. Many university buildings export, import and produce energy. The energy flows are metered by the Campus Meter Shop and then upload to several software platforms to generate mandatory energy reports for campus buildings. The Campus Meter Shop should be advised if any energy or consumption meter does not adhere to this section.
- C. Performance Requirements: Manufacturer shall certify that each energy meter indicated complies with specified performance requirements and characteristics.
1. Product certificates are required.

2. No substitutions can be provided without written approval. Requests for substitutions must be provided in writing to the submittal review group. The information below reflects acceptable manufactures and model numbers, the communication protocol, UMD groups to review and additional features.
3. Note the UMD steam distribution system is operated by a 3rd party entity and requires utility grade meters – they only accept one type of steam meter as indicated.

2.2 ELECTRIC POWER METERS

Manufacturer	Model	Communication Requirement	Submittal Review	Additional Features Required
Square D	PM 5500	ModBus RTU or BACnet MSTP RS 485	UMD Engineering & Energy, UMD CCMS, MEDCO	Modbus or BACnet communications over RS485, Panel Display.
GE	PQM II	ModBus RTU or BACnet MSTP RS 485	UMD Engineering & Energy, UMD CCMS, MEDCO	Modbus or BACnet communications over RS485, Panel Display.
Shark	270 Socket Meter Form 9S	ModBus RTU or BACnet MSTP RS 485	UMD Engineering & Energy, UMD CCMS, MEDCO	Modbus or BACnet communications over RS485, Panel Display.
Shark	250	ModBus RTU or BACnet MSTP RS 485	UMD Engineering & Energy, UMD CCMS, MEDCO	Modbus or BACnet communications over RS485, Panel Display.

2.3 STEAM METERS

Manufacturer	Model	Communication Requirement	Submittal Review	Additional Features Required
Yokogawa	DYA-Vortex with ITC	Hart and DC Pulse or 4-20ma or 0-10VDC	UMD Engineering & Energy, UMD CCMS, MEDCO	Moore Industries HCS Hart to Modbus Converter, Modbus RTU RS485, Flanged 2" & above, Unions below 2"

2.4 NATURAL GAS / PROPANE / COMPRESSED AIR

Manufacturer	Model	Communication Requirement	Submittal Review	Additional Features Required
Onicon	F5100 (Thermal Dispersion Flow Meter) w/ Display	ModBus RTU RS485	UMD Engineering & Energy, UMD CCMS, MEDCO	24VDC, Modbus RTU to BAS

Sierra	QuadraTherm® 640i Air Mass Flow Meter	ModBus RTU RS485	UMD Engineering & Energy, UMD CCMS, MEDCO	24VDC, Modbus RTU to BAS
ABB	Sensyflow FMT400-VTS Thermal Mass Flowmeter	Hart or ModBus RTU RS485 and DC Pulse or 4- 20ma or 0- 10VDC	UMD Engineering & Energy, UMD CCMS, MEDCO	24VAC, Modbus RTU RS485 or Moore Industries HCS Hart to Modbus Con- verter, Flanged 2” & above, Unions below 2”.

2.5 LIQUID FLOW METERS

Manufacturer	Model	Communication Re- quirement	Submittal Review	Additional Features Re- quired
Onicon	F3100 (Magnetic Flow Meter) w/ Remote Display	ModBus RTU RS485	UMD Engineering & Energy, UMD CCMS, MEDCO	Modbus RTU to BAS, Flanged 2” & above , Un- ions below 2”
Rosemount	8705 (Magnetic Flow Meter) w/ Remote Display	Hart and DC Pulse or 4- 20ma or 0-10VDC Pulse	UMD Engineering & Energy, UMD CCMS, MEDCO	Moore Industries HCS Hart to Modbus Converter, Mod- bus RTU RS485, Flanged 2” & above, Unions below 2”.
Yokogawa	AFX (Magnetic Flow Meter) w/ Remote Display	Hart and DC Pulse or 4- 20ma or 0-10VDC	UMD Engineering & Energy, UMD CCMS, MEDCO	Moore Industries HCS Hart to Modbus Converter, Mod- bus RTU RS485, Flanged 2” & above, Unions below 2”.

2.6 THERMAL ENERGY METERS FOR HYDRONIC HVAC SYSTEMS

Manufacturer	Model	Communication Re- quirement	Submittal Review	Additional Features Re- quired
Onicon	F3100 (Magnetic Flow Meter) w/ Remote Display	Modbus RTU and DC Pulse or (4- 20ma) or (0- 10VDC)	UMD Engineering & Energy, UMD CCMS, MEDCO	Flow Computer/ Totalizer Required, Flanged 2” or above, Unions below 2”
Rosemount	8705 (Magnetic Flow Meter) w/ Remote Display	DC Pulse or (4- 20ma) or (0- 10VDC) Pulse	UMD Engineering & Energy, UMD CCMS, MEDCO	Flow Computer/ Totalizer Required, Flanged 2” or above, Unions below 2”
Yokogawa	AFX (Magnetic Flow Meter) w/ Remote Display	DC Pulse or (4- 20ma) or (0- 10VDC)	UMD Engineering & Energy, UMD CCMS, MEDCO	Flow Computer/ Totalizer Required, Flanged 2” or above, Unions below 2”

2.7 FLOW COMPUTERS FOR METERS SPECIFIED IN SECTION 2.6 ABOVE

Manufacturer	Model	Communication Requirement	Submittal Review	Additional Features Required
Onicon	System 10	BACNET MSTP via RS 485 or Modbus RTU	UMD Engineering & Energy, UMD CCMS, MEDCO	24VAC, Matched Temperature Sensors, Dual Mode BiDirectional
Kessler-Ellis Products	KEP ST2 (Supertroll II) ES 749	Modbus RTU RS485 & 4-20ma output	UMD Engineering & Energy, UMD CCMS, MEDCO	24VDC, (2) 3-Wire 100 Ohm Platinum RTD Match Pair Temperature Sensors, Dual Mode Bi-Directional

PART 3 - EXECUTION

3.1 EXAMINATION

- A. Examine substrates and conditions for compliance with requirements for installation tolerances and other conditions affecting performance of the Work.
- B. Examine roughing-in for instruments installed in piping to verify actual locations of connections before installation.
- C. Examine roughing-in for instruments installed in duct systems to verify actual locations of connections before installation.
- D. Prepare written report, endorsed by Installer, listing conditions detrimental to performance.
- E. Proceed with installation only after unsatisfactory conditions have been corrected.

3.2 INSTALLATION, GENERAL

- A. Install products level, plumb, parallel, and perpendicular with building construction.
- B. Support instruments, tubing, piping wiring, and conduit to comply with requirements indicated. Brace all products to prevent lateral movement and sway or a break in attachment when subjected to a 25 pound force.
- C. Install products in locations that are accessible and that will permit calibration and maintenance from floor, equipment platforms, or catwalks. All meters to have a display mounted between 2' to 5' AFF. In the event a meter is located above this height the remote display must be provided and mounted the height indicated.

3.3 ELECTRIC POWER

- A. Furnish and install electrical power to products requiring electrical connections.
- B. Furnish and install circuit breakers. Comply with requirements in Section 262816 "Enclosed Switches and Circuit Breakers."
- C. Furnish and install power wiring. Comply with requirements in Section 260519 "Low-Voltage Electrical Power Conductors and Cables."
- D. Furnish and install raceways. Comply with requirements in Section 260533 "Raceways and Boxes for Electrical Systems."

3.4 DEMONSTRATION

- A. Engage a factory-authorized service representative to train Owner's maintenance personnel to adjust, operate, and maintain instrumentation and control devices.
- B. Coordinate video with operation and maintenance manuals and onsite instruction for use by Owner in operating, maintaining, and troubleshooting.
- C. Record videos on DVD disks.
- D. Owner shall have right to make additional copies of video for internal use without paying royalties.

END OF SECTION 230923.13

SECTION 231123 - FACILITY NATURAL-GAS PIPING

PART 1 - GENERAL

1.1 SUMMARY

A. Section Includes:

1. Pipes, tubes, and fittings.
2. Piping specialties.
3. Joining materials.
4. Manual gas shutoff valves.
5. Motorized gas valves.
6. Pressure regulators.
7. Dielectric fittings.

1.2 DEFINITIONS

- A. CWP: Cold working pressure.
- B. Exposed, Exterior Installations: Exposed to view outdoors or subject to outdoor ambient temperatures and weather conditions. An example includes rooftop locations.
- C. Exposed, Interior Installations: Exposed to view indoors. Examples include finished occupied spaces and mechanical equipment rooms.
- D. Finished Spaces: Spaces other than mechanical and electrical equipment rooms, furred spaces, pipe and duct shafts, unheated spaces immediately below roof, spaces above ceilings, unexcavated spaces, crawlspaces, and tunnels.

1.3 ACTION SUBMITTALS

A. Product Data:

1. Piping specialties.
2. Corrugated, stainless steel tubing with associated components.
3. Valves. Include pressure rating, capacity, settings, and electrical connection data of selected models.
4. Pressure regulators. Indicate pressure ratings and capacities.
5. Dielectric fittings.

1.4 INFORMATIONAL SUBMITTALS

A. Certificates:

1. Welding certificates.

- B. Field Quality-Control Submittals:
 - 1. Field quality-control reports.
- C. Qualification Statements: For professional engineer.

1.5 CLOSEOUT SUBMITTALS

- A. Operation and Maintenance Data: For pressure regulators to include in emergency, operation, and maintenance manuals.

1.6 QUALITY ASSURANCE

- A. Qualifications:
 - 1. Pipe Welding: Qualify procedures and operators in accordance with the ASME Boiler and Pressure Vessel Code.

1.7 DELIVERY, STORAGE, AND HANDLING

- A. Handling Flammable Liquids: Remove and dispose of liquids from existing natural-gas piping in accordance with requirements of authorities having jurisdiction.
- B. Deliver pipes and tubes with factory-applied end caps. Maintain end caps through shipping, storage, and handling to prevent pipe end damage and to prevent entrance of dirt, debris, and moisture.
- C. Store and handle pipes and tubes having factory-applied protective coatings to avoid damaging coating, and protect from direct sunlight.

1.8 PROJECT CONDITIONS

- A. Interruption of Existing Natural-Gas Service: Do not interrupt natural-gas service to facilities occupied by Owner or others unless permitted under the following conditions, and then only after arranging to provide purging and startup of natural-gas supply in accordance with requirements indicated:
 - 1. Notify Owner no fewer than 14 days in advance of proposed interruption of natural-gas service.
 - 2. Do not proceed with interruption of natural-gas service without Owner's written permission.

1.9 COORDINATION

- A. Coordinate sizes and locations of concrete bases with actual equipment provided.

- B. Coordinate requirements for piping identification for natural-gas piping. Comply with requirements in Section 220553 "Identification of Plumbing Piping and Equipment."

PART 2 - PRODUCTS

2.1 PERFORMANCE REQUIREMENTS

- A. Comply with NFPA 54 and the International Fuel Gas Code.
- B. Minimum Operating-Pressure Ratings:
 - 1. Piping and Valves: 100 psig minimum unless otherwise indicated.
 - 2. Service Regulators: 65 psig minimum unless otherwise indicated.
- C. Natural-Gas System Pressure within Buildings:
 - 1. Single Pressure: 0.5 psig or less
- D. Electrical Components, Devices, and Accessories: Listed and labeled as defined in NFPA 70, by a qualified testing agency, and marked for intended location and application.

2.2 PIPES, TUBES, AND FITTINGS

- A. Steel Pipe: ASTM A53/A53M, black steel, Schedule 40, Type E or S, Grade B.
 - 1. Malleable-Iron Threaded Fittings: ASME B16.3, Class 150, standard pattern.
 - 2. Wrought-Steel Welding Fittings: ASTM A234/A234M for butt welding and socket welding.
 - 3. Unions: ASME B16.39, Class 150, malleable iron with brass-to-iron seat, ground joint, and threaded ends.
 - 4. Forged-Steel Flanges and Flanged Fittings: ASME B16.5, minimum Class 150, including bolts, nuts, and gaskets of the following material group, end connections, and facings:
 - a. Material Group: 1.1.
 - b. End Connections: Threaded or butt welding to match pipe.
 - c. Lapped Face: Not permitted underground.
 - d. Gasket Materials: ASME B16.20, metallic, flat, asbestos free, aluminum O-rings, and spiral-wound metal gaskets.
 - e. Bolts and Nuts: ASME B18.2.1, carbon steel aboveground and stainless-steel underground.
- B. Corrugated, Stainless Steel Tubing: Comply with ANSI/IAS LC 1/CSA 6.26.
 - 1. Tubing: ASTM A240/A240M, corrugated, Series 300 stainless steel.
 - 2. Coating: PE with flame retardant.
 - a. Surface-Burning Characteristics: As determined by testing identical products in accordance with ASTM E84 by qualified testing agency. Identify products with appropriate markings of applicable testing agency.

- 1) Flame-Spread Index: 25 or less.
- 2) Smoke-Developed Index: 50 or less.
3. Fittings: Copper-alloy mechanical fittings with ends made to fit and listed for use with corrugated stainless-steel tubing and capable of metal-to-metal seal without gaskets. Include brazing socket or threaded ends complying with ASME B1.20.1.
4. Striker Plates: Steel, designed to protect tubing from penetrations.
5. Manifolds: Malleable iron or steel with factory-applied protective coating. Threaded connections are to comply with ASME B1.20.1 for pipe inlet and corrugated tubing outlets.
6. Operating-Pressure Rating: 5 psig.

2.3 PIPING SPECIALTIES

A. Appliance Flexible Connectors:

1. Indoor, Fixed-Appliance Flexible Connectors: Comply with ANSI Z21.24.
2. Corrugated, stainless steel tubing with polymer coating.
3. Operating-Pressure Rating: 0.5 psig.
4. End Fittings: Zinc-coated steel.
5. Threaded Ends: Comply with ASME B1.20.1.
6. Maximum Length: 72 inches.

B. Y-Pattern Strainers:

1. Body: ASTM A126, Class B, cast iron with bolted cover and bottom drain connection.
2. End Connections: Threaded ends for NPS 2 and smaller.
3. Strainer Screen: 40-mesh startup strainer, and perforated stainless steel basket with 50 percent free area.
4. CWP Rating: 125 psig.

C. Basket Strainers:

1. Body: ASTM A126, Class B, high-tensile cast iron with bolted cover and bottom drain connection.
2. End Connections: Threaded ends for NPS 2 and smaller; flanged ends for NPS 2-1/2 and larger.
3. Strainer Screen: 40-mesh startup strainer, and perforated stainless steel basket with 50 percent free area.
4. CWP Rating: 125 psig.

D. T-Pattern Strainers:

1. Body: Ductile or malleable iron with removable access coupling and end cap for strainer maintenance.
2. End Connections: Grooved ends.
3. Strainer Screen: 40-mesh startup strainer, and perforated stainless steel basket with 57 percent free area.
4. CWP Rating: 750 psig.

E. Weatherproof Vent Cap:

1. Cast- or malleable-iron increaser fitting with corrosion-resistant wire screen, with free area at least equal to cross-sectional area of connecting pipe and threaded-end connection.

2.4 JOINING MATERIALS

- A. Joint Compound and Tape: Suitable for natural gas.
- B. Welding Filler Metals: Comply with AWS D10.12/D10.12M for welding materials appropriate for wall thickness and chemical analysis of steel pipe being welded.
- C. Brazing Filler Metals: Alloy with melting point greater than 1000 deg F complying with AWS A5.8/A5.8M. Brazing alloys containing more than 0.05 percent phosphorus are prohibited.

2.5 MOTORIZED GAS VALVES

- A. Automatic Gas Valves: Comply with ANSI Z21.21.
1. Body: Brass or aluminum.
 2. Seats and Disc: NBR.
 3. Springs and Valve Trim: Stainless steel.
 4. Normally closed.
 5. Visual position indicator.
 6. Electrical actuator operated by appliance automatic shutoff device.
- B. Electrically Operated Valves: Comply with UL 429.
1. Pilot operated.
 2. Body: Brass or aluminum.
 3. Seats and Disc: NBR.
 4. Springs and Valve Trim: Stainless steel.
 5. 120 V ac, 60 Hz, Class B, continuous-duty molded coil, and replaceable.
 6. NEMA ICS 6, Type 4, coil enclosure.
 7. Normally closed.
 8. Visual position indicator.

2.6 MANUAL GAS SHUTOFF VALVES

- A. General Requirements for Metallic Valves, NPS 2 and Smaller: Comply with ASME B16.33.
1. CWP Rating: 125 psig.
 2. Threaded Ends: Comply with ASME B1.20.1.
 3. Dryseal Threads on Flare Ends: Comply with ASME B1.20.3.
 4. Tamperproof Feature: Locking feature for valves indicated in "Aboveground, Manual Gas Shutoff Valve Schedule" articles.
 5. Listed and labeled by an NRTL acceptable to authorities having jurisdiction for valves 1 inch and smaller.
 6. Service Mark: Valves NPS 1-1/4 to NPS 2 having initials "WOG" permanently marked on valve body.

- B. General Requirements for Metallic Valves, NPS 2-1/2 and Larger: Comply with ASME B16.38.
1. CWP Rating: 125 psig.
 2. Flanged Ends: Comply with ASME B16.5 for steel flanges.
 3. Tamperproof Feature: Locking feature for valves indicated in "Underground, Manual Gas Shutoff Valve Schedule" and "Aboveground, Manual Gas Shutoff Valve Schedule" articles.
 4. Service Mark: Initials "WOG" permanently marked on valve body.
- C. One-Piece, Bronze Ball Valve with Bronze Trim: MSS SP-110.
1. Manufacturers: Subject to compliance with requirements, provide products by one of the following:
 - a. Apollo Valves
 - b. NIBCO INC.
 - c. WATTS.
 2. Body: Bronze, complying with ASTM B584.
 3. Ball: Chrome-plated brass.
 4. Stem: Bronze; blowout proof.
 5. Seats: Reinforced TFE; blowout proof.
 6. Packing: Separate packnut with adjustable-stem packing threaded ends.
 7. Ends: Threaded, flared, or socket as indicated in "Underground, Manual Gas Shutoff Valve Schedule" and "Aboveground, Manual Gas Shutoff Valve Schedule" articles.
 8. CWP Rating: 600 psig.
 9. Listing: Valves NPS 1 and smaller are to be listed and labeled by an NRTL acceptable to authorities having jurisdiction.
 10. Service: Suitable for natural-gas service with "WOG" indicated on valve body.
- D. Two-Piece, Full-Port, Bronze Ball Valves with Bronze Trim: MSS SP-110.
1. Manufacturers: Subject to compliance with requirements, provide products by one of the following:
 - a. Apollo Valves
 - b. NIBCO INC.
 - c. WATTS.
 2. Body: Bronze, complying with ASTM B584.
 3. Ball: Chrome-plated bronze.
 4. Stem: Bronze; blowout proof.
 5. Seats: Reinforced TFE; blowout proof.
 6. Packing: Threaded-body packnut design with adjustable-stem packing.
 7. Ends: Threaded, flared, or socket as indicated in "Underground, Manual Gas Shutoff Valve Schedule" and "Aboveground, Manual Gas Shutoff Valve Schedule" articles.
 8. CWP Rating: 600 psig.
 9. Listing: Valves NPS 1 and smaller are to be listed and labeled by an NRTL acceptable to authorities having jurisdiction.
 10. Service: Suitable for natural-gas service with "WOG" indicated on valve body.

E. Bronze Plug Valves: MSS SP-78.

1. Manufacturers: Subject to compliance with requirements, provide products by one of the following:
 - a. A.Y. McDonald Mfg. Co.
 - b. Lee Brass Company.
2. Body: Bronze, complying with ASTM B584.
3. Plug: Bronze.
4. Ends: Threaded, socket, or flanged as indicated in "Underground, Manual Gas Shutoff Valve Schedule" and "Aboveground, Manual Gas Shutoff Valve Schedule" articles.
5. Operator: Square head or lug type with tamperproof feature where indicated.
6. Pressure Class: 125 psig.
7. Listing: Valves NPS 1 and smaller are to be listed and labeled by an NRTL acceptable to authorities having jurisdiction.
8. Service: Suitable for natural-gas service with "WOG" indicated on valve body.

F. Cast-Iron, Nonlubricated Plug Valves: MSS SP-78.

1. Manufacturers: Subject to compliance with requirements, provide products by one of the following:
 - a. A.Y. McDonald Mfg. Co.
 - b. Mueller Co.
2. Body: Cast iron, complying with ASTM A126, Class B.
3. Plug: Bronze or nickel-plated cast iron.
4. Seat: Coated with thermoplastic.
5. Stem Seal: Compatible with natural gas.
6. Ends: Threaded or flanged as indicated in "Underground, Manual Gas Shutoff Valve Schedule" and "Aboveground, Manual Gas Shutoff Valve Schedule" articles.
7. Operator: Square head or lug type with tamperproof feature where indicated.
8. Pressure Class: 125 psig.
9. Listing: Valves NPS 1 and smaller are to be listed and labeled by an NRTL acceptable to authorities having jurisdiction.
10. Service: Suitable for natural-gas service with "WOG" indicated on valve body.

G. Cast-Iron, Lubricated Plug Valves: MSS SP-78.

1. Manufacturers: Subject to compliance with requirements, provide products by one of the following:
 - a. A.Y. McDonald Mfg. Co.
 - b. Flowserve Corporation.
 - c. Homestead Valve, a division of Olson Technologies, Inc.
 - d. Milliken Valve Company.
 - e. Mueller Co.
 - f. R & M Energy Systems; Robbins & Myers.
2. Body: Cast iron, complying with ASTM A126, Class B.

3. Plug: Bronze or nickel-plated cast iron.
4. Seat: Coated with thermoplastic.
5. Stem Seal: Compatible with natural gas.
6. Ends: Threaded or flanged as indicated in "Underground, Manual Gas Shutoff Valve Schedule" and "Aboveground, Manual Gas Shutoff Valve Schedule" articles.
7. Operator: Square head or lug type with tamperproof feature where indicated.
8. Pressure Class: 125 psig.
9. Listing: Valves NPS 1 and smaller are to be listed and labeled by an NRTL acceptable to authorities having jurisdiction.
10. Service: Suitable for natural-gas service with "WOG" indicated on valve body.

2.7 PRESSURE REGULATORS

A. General Requirements:

1. Single stage and suitable for natural gas.
2. Steel jacket and corrosion-resistant components.
3. Elevation compensator.
4. End Connections: Threaded for regulators NPS 2 and smaller; flanged for regulators NPS 2-1/2 and larger.

B. Appliance Pressure Regulators: Comply with ANSI Z21.18.

1. Manufacturers: Subject to compliance with requirements, provide products by one of the following:
 - a. Canadian Meter Company Inc.
 - b. Dormont; a WATTS brand.
 - c. Eaton.
 - d. Harper Wyman Co.
 - e. Maxitrol Company.
 - f. SCP, Inc.
 - 1) Body and Diaphragm Case: Die-cast aluminum.
 - 2) Springs: Zinc-plated steel; interchangeable.
 - 3) Diaphragm Plate: Zinc-plated steel.
 - 4) Seat Disc: NBR.
 - 5) Seal Plug: UV-stabilized, mineral-filled nylon.
 - 6) Factory-Applied Finish: Minimum three-layer polyester and polyurethane paint finish.
 - 7) Regulator may include vent limiting device, instead of vent connection, if approved by authorities having jurisdiction.
 - 8) Maximum Inlet Pressure: 0.5 psig.

2.8 DIELECTRIC FITTINGS

- ### A. General Requirements: Assembly of copper alloy and ferrous materials with separating nonconductive insulating material. Include end connections compatible with pipes to be joined.

B. Dielectric Unions:

1. Manufacturers: Subject to compliance with requirements, provide products by one of the following:
 - a. A.Y. McDonald Mfg. Co.
 - b. Capitol Manufacturing Company.
 - c. Central Plastics Company.
 - d. HART Industrial Unions, LLC.
 - e. Jomar Valve.
 - f. Matco-Norca.
2. Description:
 - a. Standard: ASSE 1079.
 - b. Pressure Rating: 125 psig minimum at 180 deg F.
 - c. End Connections: Solder-joint copper alloy and threaded ferrous.

C. Dielectric Flanges:

1. Manufacturers: Subject to compliance with requirements, provide products by one of the following:
 - a. Capitol Manufacturing Company.
 - b. Central Plastics Company.
 - c. Matco-Norca.
2. Description:
 - a. Standard: ASSE 1079.
 - b. Factory-fabricated, bolted, companion-flange assembly.
 - c. Pressure Rating: 125 psig minimum at 180 deg F.
 - d. End Connections: Solder-joint copper alloy and threaded ferrous; threaded solder-joint copper alloy and threaded ferrous.

D. Dielectric-Flange Insulating Kits:

1. Manufacturers: Subject to compliance with requirements, provide products by one of the following:
 - a. Advance Products & Systems, Inc.
 - b. Calpico, Inc.
 - c. Central Plastics Company.
 - d. Pipeline Seal and Insulator, Inc.
2. Description:
 - a. Nonconducting materials for field assembly of companion flanges.
 - b. Pressure Rating: 150 psig.
 - c. Gasket: Neoprene or phenolic.
 - d. Bolt Sleeves: Phenolic or polyethylene.

- e. Washers: Phenolic with steel backing washers.

2.9 LABELING AND IDENTIFYING

- A. Detectable Warning Tape: Acid- and alkali-resistant, PE film warning tape manufactured for marking and identifying underground utilities, a minimum of 6 inches wide and 4 mils thick, continuously inscribed with a description and rated pressure of utility, with metallic core encased in a protective jacket for corrosion protection, detectable by metal detector when tape is buried up to 30 inches deep; colored yellow.
- B. Label and identify gas piping and pressure outside a multitenant building by tenant.

PART 3 - EXECUTION

3.1 EXAMINATION

- A. Examine roughing-in for natural-gas piping system to verify actual locations of piping connections before equipment installation.
- B. Proceed with installation only after unsatisfactory conditions have been corrected.

3.2 PREPARATION

- A. Close equipment shutoff valves before turning off natural gas to premises or piping section.
- B. Inspect natural-gas piping in accordance with NFPA 54 and the International Fuel Gas Code to determine that natural-gas utilization devices are turned off in piping section affected.
- C. Comply with NFPA 54 and the International Fuel Gas Code requirements for preventing accidental ignition.

3.3 INSTALLATION OF INDOOR PIPING

- A. Comply with NFPA 54 and the International Fuel Gas Code for installation and purging of natural-gas piping.
- B. Drawing plans, schematics, and diagrams indicate general location and arrangement of piping systems. Indicated locations and arrangements are used to size pipe and calculate friction loss, expansion, and other design considerations. Install piping as indicated unless deviations to layout are approved on Coordination Drawings.
- C. Arrange for pipe spaces, chases, slots, sleeves, and openings in building structure during progress of construction, to allow for mechanical installations.
- D. Do not install piping in concealed locations unless sleeved with the sleeve open at both ends.

- E. Install piping indicated to be exposed and piping in equipment rooms and service areas at right angles or parallel to building walls. Diagonal runs are prohibited unless specifically indicated otherwise.
- F. Where installing piping above accessible ceilings, allow sufficient space for ceiling panel removal.
- G. Locate valves for easy access. Do not locate valves within return air plenums.
- H. Install natural-gas piping at uniform grade of 2 percent down toward drip and sediment traps.
- I. Install piping free of sags and bends.
- J. Install fittings for changes in direction and branch connections.
- K. Verify final equipment locations for roughing-in.
- L. Comply with requirements in Sections specifying gas-fired appliances and equipment for roughing-in requirements.
- M. Drips and Sediment Traps: Install drips at points where condensate may collect, including service-meter outlets. Locate where accessible to permit cleaning and emptying. Do not install where condensate is subject to freezing.
 - 1. Construct drips and sediment traps using tee fitting with bottom outlet plugged or capped. Use nipple a minimum length of 3 pipe diameters, but not less than 3 inches long and same size as connected pipe. Install with space below bottom of drip to remove plug or cap.
- N. Extend relief vent connections for service regulators, line regulators, and overpressure protection devices to outdoors and terminate with weatherproof vent cap.
- O. Conceal pipe installations in walls, pipe spaces, utility spaces, above ceilings, below grade or floors, and in floor channels unless indicated to be exposed to view.
- P. Concealed Location Installations: Except as specified below, install concealed natural-gas piping and piping installed under the building in containment conduit constructed of steel pipe with welded joints as described in Part 2. Install a vent pipe from containment conduit to outdoors and terminate with weatherproof vent cap.
- Q. Use eccentric reducer fittings to make reductions in pipe sizes. Install fittings with level side down.
- R. Connect branch piping from top or side of horizontal piping.
- S. Install unions in pipes NPS 2 and smaller, adjacent to each valve, at final connection to each piece of equipment. Unions are not required at flanged connections.
- T. Do not use natural-gas piping as grounding electrode.
- U. Install strainer on inlet of each line-pressure regulator and automatic or electrically operated valve.

- V. Install pressure gauge upstream and downstream from each line regulator. Pressure gauges are specified in Section 230519 "Meters and Gauges for HVAC Piping."

3.4 INSTALLATION OF VALVES

- A. Install manual gas shutoff valve for each gas appliance ahead of corrugated stainless steel tubing, aluminum, or copper connector.
- B. Install regulators and overpressure protection devices with maintenance access space adequate for servicing and testing.
- C. Do not install valves in return-air plenums.

3.5 PIPING JOINT CONSTRUCTION

- A. Ream ends of pipes and tubes and remove burrs.
- B. Remove scale, slag, dirt, and debris from inside and outside of pipe and fittings before assembly.
- C. Threaded Joints:
 - 1. Thread pipe with tapered pipe threads complying with ASME B1.20.1.
 - 2. Cut threads full and clean using sharp dies.
 - 3. Ream threaded pipe ends to remove burrs and restore full inside diameter of pipe.
 - 4. Apply appropriate tape or thread compound to external pipe threads unless dryseal threading is specified.
 - 5. Damaged Threads: Do not use pipe or pipe fittings with threads that are corroded or damaged. Do not use pipe sections that have cracked or open welds.
- D. Welded Joints:
 - 1. Construct joints in accordance with AWS D10.12/D10.12M, using qualified processes and welding operators.
 - 2. Bevel plain ends of steel pipe.
 - 3. Patch factory-applied protective coating as recommended by manufacturer at field welds and where damage to coating occurs during construction.
- E. Brazed Joints: Construct joints in accordance with AWS's "Brazing Handbook," "Pipe and Tube" Chapter.
- F. Flanged Joints: Install gasket material, size, type, and thickness appropriate for natural-gas service. Install gasket concentrically positioned.
- G. Flared Joints: Cut tubing with roll cutting tool. Flare tube end with tool to result in flare dimensions complying with SAE J513. Tighten finger tight, and then use wrench. Do not overtighten.
- H. PE Piping Heat-Fusion Joints: Clean and dry joining surfaces by wiping with clean cloth or paper towels. Join in accordance with ASTM D2657.

1. Plain-End Pipe and Fittings: Use butt fusion.
2. Plain-End Pipe and Socket Fittings: Use socket fusion.

3.6 INSTALLATION OF HANGERS AND SUPPORTS

- A. Comply with requirements in Section 230529 "Hangers and Supports for HVAC Piping and Equipment" for hangers, supports, and anchor devices.
- B. Install hangers for steel piping, with maximum horizontal spacing and minimum rod diameters, to comply with MSS SP-58, locally enforced codes, and authorities having jurisdiction requirements, whichever are most stringent.
- C. Install hangers for corrugated stainless steel tubing, with maximum horizontal spacing and minimum rod diameters, to comply with manufacturer's written instructions, locally enforced codes, and authorities having jurisdiction requirements, whichever are most stringent.
- D. Support horizontal piping within 12 inches of each fitting.
- E. Support vertical runs of steel piping to comply with MSS SP-58, locally enforced codes, and authorities having jurisdiction requirements, whichever are most stringent.
- F. Support vertical runs of corrugated stainless-steel tubing to comply with manufacturer's written instructions, locally enforced codes, and authorities having jurisdiction requirements, whichever are most stringent.

3.7 PIPING CONNECTIONS

- A. Connect to utility's gas main in accordance with utility's procedures and requirements.
- B. Install natural-gas piping electrically continuous, and bonded to gas-appliance equipment grounding conductor of the circuit powering the appliance in accordance with NFPA 70.
- C. Where installing piping adjacent to appliances, allow space for service and maintenance of appliances.
- D. Connect piping to appliances using manual gas shutoff valves and unions. Install valve within 72 inches of each gas-fired appliance and equipment. Install union between valve and appliances or equipment.

3.8 LABELING AND IDENTIFICATION

- A. Comply with requirements in on call specifications, Section 230553 "Identification for HVAC Piping and Equipment" for piping and valve identification.

3.9 FIELD QUALITY CONTROL

- A. Tests and Inspections:

1. Test, inspect, and purge natural gas in accordance with NFPA 54 and the International Fuel Gas Code and authorities having jurisdiction.
2. Natural-gas piping will be considered defective if it does not pass tests and inspections.

B. Prepare test and inspection reports.

3.10 INDOOR PIPING SCHEDULE FOR SYSTEM PRESSURES LESS THAN 0.5 PSIG

A. Aboveground, branch piping NPS 1 and smaller is to be one of the following:

1. Corrugated stainless steel tubing with mechanical fittings having socket or threaded ends to match adjacent piping.
2. Steel pipe with malleable-iron fittings and threaded joints.

B. Aboveground, distribution piping is to be one of the following:

1. Steel pipe with malleable-iron fittings and threaded joints.
2. Steel pipe with wrought-steel fittings and welded joints.

3.11 ABOVEGROUND, MANUAL GAS SHUTOFF VALVE SCHEDULE

A. Valves for pipe sizes NPS 2 and smaller at service meter are to be one of the following:

1. One-piece, bronze ball valve with bronze trim.
2. Two-piece, full-port, bronze ball valves with bronze trim.
3. Bronze plug valve.

B. Valves for pipe sizes NPS 2-1/2 and larger at service meter are to be one of the following:

1. Two-piece, full-port, bronze ball valves with bronze trim.
2. Bronze plug valve.
3. Cast-iron, nonlubricated plug valve.

C. Distribution piping valves for pipe sizes NPS 2 and smaller are to be one of the following:

1. One-piece, bronze ball valve with bronze trim.
2. Two-piece, full-port, bronze ball valves with bronze trim.
3. Bronze plug valve.

D. Distribution piping valves for pipe sizes NPS 2-1/2 and larger are to be one of the following:

1. Two-piece, full-port, bronze ball valves with bronze trim.
2. Bronze plug valve.
3. Cast-iron, nonlubricated plug valve.

E. Valves in branch piping for single appliance are to be one of the following:

1. One-piece, bronze ball valve with bronze trim.
2. Two-piece, full-port, bronze ball valves with bronze trim.
3. Bronze plug valve.

END OF SECTION 231123

SECTION 232113 - HYDRONIC PIPING

PART 1 - GENERAL

1.1 RELATED DOCUMENTS

- A. Drawings and general provisions of the Contract, including General and Supplementary Conditions and Division 01 Specification Sections, apply to this Section.

1.2 SUMMARY

- A. This Section includes pipe and fitting materials, joining methods, special-duty valves, and specialties for the following:
 - 1. Hot-water heating piping.
 - 2. Chilled-water piping.
 - 3. Dual-temperature heating and cooling water piping.
 - 4. Condenser-water piping.
 - 5. Glycol cooling-water piping.
 - 6. Makeup-water piping.
 - 7. Air Conditioning Condensate-drain piping.
 - 8. Blowdown-drain piping.
 - 9. Air-vent piping.
 - 10. Safety-valve-inlet and -outlet piping.
- B. Related Sections include the following:
 - 1. Division 23 Section "Hydronic Pumps" for pumps, motors, and accessories for hydronic piping.
 - 2. Division 23 Section "Steam & Condensate Heating Piping"
 - 3. Division 23 Section "HVAC Water Treatment"

1.3 PERFORMANCE REQUIREMENTS

- A. Hydronic piping components and installation shall be capable of withstanding the following minimum working pressure and temperature:
 - 1. Hot-Water Heating Piping: 150 psig at 200 deg F.
 - 2. Chilled-Water Piping: 150 psig at 200 deg F.
 - 3. Dual-Temperature Heating and Cooling Water Piping: 150 psig at 200 deg F.
 - 4. Condenser-water piping: 150 psig at 150 deg F.
 - 5. Glycol cooling-water piping: 150 psig at 150 deg F.
 - 6. Makeup-water piping: 80 psig at 150 deg F.
 - 7. Air Conditioning Condensate-drain piping: 150 deg F.
 - 8. Blowdown-drain piping: 200 deg F.

9. Air-vent piping: 200 deg F.
 10. Safety-Valve-Inlet and -Outlet Piping: Equal to the pressure of the piping system to which it is attached.
- B. Grooved Joint Piping is not acceptable.

1.4 SUBMITTALS

- A. Product Data: For each type of the following:
1. Pressure-seal fittings.
 2. Valves. Include flow and pressure drop curves based on manufacturer's testing for calibrated-orifice balancing valves and automatic flow-control valves.
 3. Air control devices.
 4. Chemical treatment.
 5. Hydronic specialties.
- B. Shop Drawings: Detail, at 1/4" scale, the piping layout, fabrication of pipe anchors, hangers, supports for multiple pipes, alignment guides, expansion joints and loops, and attachments of the same to the building structure. Detail location of anchors, alignment guides, and expansion joints and loops.
- C. Welding certificates.
- D. Qualification Data: For Installer.
- E. Field quality-control test reports.
- F. Operation and Maintenance Data: For air control devices, hydronic specialties, and special-duty valves to include in emergency, operation, and maintenance manuals.
- G. Water Analysis: Submit a copy of the water analysis to illustrate water quality available at Project site.

1.5 QUALITY ASSURANCE

- A. Installer Qualifications:
1. Installers of Pressure-Sealed Joints: Installers shall be certified by the pressure-seal joint manufacturer as having been trained and qualified to join piping with pressure-seal pipe couplings and fittings.
 2. Fiberglass Pipe and Fitting Installers: Installers of RTRF and RTRP shall be certified by the manufacturer of pipes and fittings as having been trained and qualified to join fiberglass piping with manufacturer-recommended adhesive.

- B. Steel Support Welding: Qualify processes and operators according to AWS D1.1/D1.1M, "Structural Welding Code - Steel."
- C. Welding: Qualify processes and operators according to ASME Boiler and Pressure Vessel Code: Section IX.
 - 1. Comply with provisions in ASME B31 Series, "Code for Pressure Piping."
 - 2. Certify that each welder has passed AWS qualification tests for welding processes involved and that certification is current.
- D. ASME Compliance: Comply with ASME B31.9, "Building Services Piping," for materials, products, and installation. Safety valves and pressure vessels shall bear the appropriate ASME label. Fabricate and stamp air separators and expansion tanks to comply with ASME Boiler and Pressure Vessel Code: Section VIII, Division 01.

1.6 EXTRA MATERIALS

- A. Water-Treatment Chemicals: Furnish enough chemicals for initial system startup and for preventive maintenance for one year from date of Substantial Completion.
- B. Differential Pressure Meter: For each type of balancing valve and automatic flow control valve, include flowmeter, probes, hoses, flow charts, and carrying case.

PART 2 - PRODUCTS

2.1 COPPER TUBE AND FITTINGS

- A. Drawn-Temper Copper Tubing: ASTM B 88, Type L.
- B. Wrought-Copper Fittings: ASME B16.22.
 - 1. Available Manufacturers: Subject to compliance with requirements, manufacturers offering products that may be incorporated into the Work include, but are not limited to, the following:
 - 2. Basis-of-Design Product: Subject to compliance with requirements, provide product by one of the following:
 - a. Anvil International, Inc.
 - b. S. P. Fittings; a division of Star Pipe Products.
 - c. Victaulic Company of America.
- C. Copper or Bronze Pressure-Seal Fittings:

1. Available Manufacturers: Subject to compliance with requirements, manufacturers offering products that may be incorporated into the Work include, but are not limited to, the following:
 - a. Stadler-Viega.
 2. Housing: Copper.
 3. O-Rings and Pipe Stops: EPDM.
 4. Tools: Manufacturer's special tools.
 5. Minimum 200-psig working-pressure rating at 250 deg F .
- D. Copper, Mechanically Formed Tee Option: For forming T-branch on copper water tube.
1. Available Manufacturers: Subject to compliance with requirements, manufacturers offering products that may be incorporated into the Work include, but are not limited to, the following:
 - a. T-DRILL Industries Inc.
- E. Wrought-Copper Unions: ASME B16.22.

2.2 STEEL PIPE AND FITTINGS

- A. Steel Pipe: ASTM A 53/A 53M, black steel with plain ends; type, grade, and wall thickness as indicated in Part 3 "Piping Applications" Article.
- B. Malleable-Iron Threaded Fittings: ASME B16.3, Classes 150 and 300 as indicated in Part 3 "Piping Applications" Article.
- C. Malleable-Iron Unions: ASME B16.39; Classes 150, 250, and 300 as indicated in Part 3 "Piping Applications" Article.
- D. Cast-Iron Pipe Flanges and Flanged Fittings: ASME B16.1, Classes 25, 125, and 250; raised ground face, and bolt holes spot faced as indicated in Part 3 "Piping Applications" Article.
- E. Wrought-Steel Fittings: ASTM A 234/A 234M, wall thickness to match adjoining pipe.
- F. Wrought Cast- and Forged-Steel Flanges and Flanged Fittings: ASME B16.5, including bolts, nuts, and gaskets of the following material group, end connections, and facings:
 1. Material Group: 1.1.
 2. End Connections: Butt welding.
 3. Facings: Raised face.

- G. Steel Pressure-Seal Fittings:
 - 1. Available Manufacturers: Subject to compliance with requirements, manufacturers offering products that may be incorporated into the Work include, but are not limited to, the following:
 - a. Victaulic Company of America.
 - 2. Housing: Steel.
 - 3. O-Rings and Pipe Stop: EPDM.
 - 4. Tools: Manufacturer's special tool.
 - 5. Minimum 300-psig working-pressure rating at 230 deg F.
- H. Steel Pipe Nipples: ASTM A 733, made of same materials and wall thicknesses as pipe in which they are installed.

2.3 JOINING MATERIALS

- A. Pipe-Flange Gasket Materials: Suitable for chemical and thermal conditions of piping system contents.
 - 1. ASME B16.21, nonmetallic, flat, asbestos free, 1/8-inch maximum thickness unless thickness or specific material is indicated.
 - a. Full-Face Type: For flat-face, Class 125, cast-iron and cast-bronze flanges.
 - b. Narrow-Face Type: For raised-face, Class 250, cast-iron and steel flanges.
- B. Flange Bolts and Nuts: ASME B18.2.1, carbon steel, unless otherwise indicated.
- C. Plastic, Pipe-Flange Gasket, Bolts, and Nuts: Type and material recommended by piping system manufacturer, unless otherwise indicated.
- D. Solder Filler Metals: ASTM B 32, lead-free alloys. Include water-flushable flux according to ASTM B 813.
- E. Brazing Filler Metals: AWS A5.8, BCuP Series, copper-phosphorus alloys for joining copper with copper; or BA9-1, silver alloy for joining copper with bronze or steel.
- F. Welding Filler Metals: Comply with AWS D10.12/D10.12M for welding materials appropriate for wall thickness and chemical analysis of steel pipe being welded.
- G. Solvent Cements for Joining Plastic Piping:
- H. Gasket Material: Thickness, material, and type suitable for fluid to be handled and working temperatures and pressures.

2.4 DIELECTRIC FITTINGS

- A. Description: Combination fitting of copper-alloy and ferrous materials with threaded, solder-joint, plain, or weld-neck end connections that match piping system materials.
- B. Insulating Material: Suitable for system fluid, pressure, and temperature.
- C. Dielectric Unions:
 - 1. Available Manufacturers: Subject to compliance with requirements, manufacturers offering products that may be incorporated into the Work include, but are not limited to, the following:
 - a. Capitol Manufacturing Company.
 - b. Central Plastics Company.
 - c. Hart Industries International, Inc.
 - d. Watts Regulator Co.; a division of Watts Water Technologies, Inc.
 - e. Zurn Plumbing Products Group; AquaSpec Commercial Products Division.
 - 2. Factory-fabricated union assembly, for 250-psig minimum working pressure at 180 deg F.
- D. Dielectric Flanges:
 - 1. Available Manufacturers: Subject to compliance with requirements, manufacturers offering products that may be incorporated into the Work include, but are not limited to, the following:
 - a. Capitol Manufacturing Company.
 - b. Central Plastics Company.
 - c. Watts Regulator Co.; a division of Watts Water Technologies, Inc.
 - 2. Factory-fabricated companion-flange assembly, for 150- or 300-psig minimum working pressure as required to suit system pressures.
- E. Dielectric-Flange Kits:
 - 1. Available Manufacturers: Subject to compliance with requirements, manufacturers offering products that may be incorporated into the Work include, but are not limited to, the following:
 - a. Advance Products & Systems, Inc.
 - b. Calpico, Inc.

- c. Central Plastics Company.
 - d. Pipeline Seal and Insulator, Inc.
 - 2. Companion-flange assembly for field assembly. Include flanges, full-face- or ring-type neoprene or phenolic gasket, phenolic or polyethylene bolt sleeves, phenolic washers, and steel backing washers.
 - 3. Separate companion flanges and steel bolts and nuts shall have 150- or 300-psig minimum working pressure where required to suit system pressures.
- F. Dielectric Couplings:
- 1. Available Manufacturers: Subject to compliance with requirements, manufacturers offering products that may be incorporated into the Work include, but are not limited to, the following:
 - a. Calpico, Inc.
 - b. Lochinvar Corporation.
 - 2. Galvanized-steel coupling with inert and noncorrosive thermoplastic lining; threaded ends; and 300-psig minimum working pressure at 225 deg F.
- G. Dielectric Nipples:
- 1. Available Manufacturers: Subject to compliance with requirements, manufacturers offering products that may be incorporated into the Work include, but are not limited to, the following:
 - a. Perfection Corporation; a subsidiary of American Meter Company.
 - b. Precision Plumbing Products, Inc.
 - c. Sioux Chief Manufacturing Company, Inc.
 - d. Victaulic Company of America.
 - 2. Electroplated steel nipple with inert and noncorrosive, thermoplastic lining; plain, threaded, or grooved ends; and 300-psig minimum working pressure at 225 deg F.

2.5 VALVES

- A. Gate, Globe, Check, Ball, and Butterfly Valves: Comply with requirements specified in Division 23 Section "General-Duty Valves for HVAC Piping."
- B. Automatic Temperature-Control Valves, Actuators, and Sensors: Comply with requirements specified in Division 23 Section "Direct Digital Control (DDC) for HVAC."

C. Bronze, Calibrated-Orifice, Balancing Valves:

1. Available Manufacturers: Subject to compliance with requirements, manufacturers offering products that may be incorporated into the Work include, but are not limited to, the following:
 - a. Armstrong Pumps, Inc.
 - b. Bell & Gossett Domestic Pump; a division of ITT Industries.
 - c. Flow Design Inc.
 - d. Gerand Engineering Co.
 - e. Griswold Controls.
 - f. Taco.
2. Body: Bronze, ball or plug type with calibrated orifice or venturi.
3. Ball: Brass or stainless steel.
4. Plug: Resin.
5. Seat: PTFE.
6. End Connections: Threaded or socket.
7. Pressure Gage Connections: Integral seals for portable differential pressure meter.
8. Handle Style: Lever, with memory stop to retain set position.
9. CWP Rating: Minimum 125 psig.
10. Maximum Operating Temperature: 250 deg F.

D. Ductile-Iron or Steel, Calibrated-Orifice, Balancing Valves:

1. Available Manufacturers: Subject to compliance with requirements, manufacturers offering products that may be incorporated into the Work include, but are not limited to, the following:
 - a. Armstrong Pumps, Inc.
 - b. Bell & Gossett Domestic Pump; a division of ITT Industries.
 - c. Flow Design Inc.
 - d. Gerand Engineering Co.

- e. Griswold Controls.
- f. Taco.
- g. Tour & Andersson; available through Victaulic Company of America.
2. Body: Cast-iron or steel body, ball, plug, or globe pattern with calibrated orifice or venturi.
3. Ball: Brass or stainless steel.
4. Stem Seals: EPDM O-rings.
5. Disc: Glass and carbon-filled PTFE.
6. Seat: PTFE.
7. End Connections: Flanged or grooved.
8. Pressure Gage Connections: Integral seals for portable differential pressure meter.
9. Handle Style: Lever, with memory stop to retain set position.
10. CWP Rating: Minimum 125 psig.
11. Maximum Operating Temperature: 250 deg F.

E. Diaphragm-Operated, Pressure-Reducing Valves:

1. Available Manufacturers: Subject to compliance with requirements, manufacturers offering products that may be incorporated into the Work include, but are not limited to, the following:
 - a. Armstrong Pumps, Inc.
 - b. Bell & Gossett Domestic Pump; a division of ITT Industries.
 - c. Conbraco Industries, Inc.
 - d. Spence Engineering Company, Inc.
 - e. Watts Regulator Co.; a division of Watts Water Technologies, Inc.
2. Body: Bronze or brass.
3. Disc: Glass and carbon-filled PTFE.
4. Seat: Brass.
5. Stem Seals: EPDM O-rings.

6. Diaphragm: EPT.
7. Low inlet-pressure check valve.
8. Inlet Strainer: Stainless steel, removable without system shutdown.
9. Valve Seat and Stem: Noncorrosive.
10. Valve Size, Capacity, and Operating Pressure: Selected to suit system in which installed, with operating pressure and capacity factory set and field adjustable.

F. Diaphragm-Operated Safety Valves:

1. Available Manufacturers: Subject to compliance with requirements, manufacturers offering products that may be incorporated into the Work include, but are not limited to, the following:
 - a. Amtrol, Inc.
 - b. Armstrong Pumps, Inc.
 - c. Bell & Gossett Domestic Pump; a division of ITT Industries.
 - d. Conbraco Industries, Inc.
 - e. Spence Engineering Company, Inc.
 - f. Watts Regulator Co.; a division of Watts Water Technologies, Inc.
2. Body: Bronze or brass.
3. Disc: Glass and carbon-filled PTFE.
4. Seat: Brass.
5. Stem Seals: EPDM O-rings.
6. Diaphragm: EPT.
7. Wetted, Internal Work Parts: Brass and rubber.
8. Inlet Strainer: Stainless steel, removable without system shutdown.
9. Valve Seat and Stem: Noncorrosive.
10. Valve Size, Capacity, and Operating Pressure: Comply with ASME Boiler and Pressure Vessel Code: Section IV, and selected to suit system in which installed, with operating pressure and capacity factory set and field adjustable.

G. Automatic Flow-Control Valves:

1. Available Manufacturers: Subject to compliance with requirements, manufacturers offering products that may be incorporated into the Work include, but are not limited to, the following:
 - a. Flow Design Inc.
 - b. Griswold Controls.
2. Body: Brass or ferrous metal.
3. Piston and Spring Assembly: Stainless steel, tamper proof, self cleaning, and removable.
4. Combination Assemblies: Include bronze or brass-alloy ball valve.
5. Identification Tag: Marked with zone identification, valve number, and flow rate.
6. Size: Same as pipe in which installed.
7. Performance: Maintain constant flow, plus or minus 5 percent over system pressure fluctuations.
8. Minimum CWP Rating: 175 psig 300 psig.
9. Maximum Operating Temperature: 250 deg F.

H. Differential Pressure Control Valves:

1. Available Manufacturers: Subject to compliance with requirements, manufacturers offering products that may be incorporated into the Work include, but are not limited to, the following:
 - a. OCV
 - b. Crane
 - c. Zurn Wilkins.
2. Body: Ductile Iron.
3. Piston and Spring Assembly: 304/302 Stainless Steel.
4. The control pilot shall be bronze, isolation valve shall be brass, and the control line tubing shall be copper.
5. Control and Pressure Differential: Provide schedule with submittal with range and pressure coordinated with building automation set points.
 - a. Spring Range: 5-30 PSI, 20-80 PSI, 20-200 PSI (Selected for application).

6. Size: Same as pipe in which installed.
7. Minimum CWP Rating: 150 psig
8. Minimum Operating Temperature: 32 deg F.
9. Maximum Operating Temperature: 250 deg F.

2.6 AIR CONTROL DEVICES

- A. Available Manufacturers: Subject to compliance with requirements, manufacturers offering products that may be incorporated into the Work include, but are not limited to, the following:
 1. Amtrol, Inc.
 2. Armstrong Pumps, Inc.
 3. Bell & Gossett Domestic Pump; a division of ITT Industries.
 4. Taco.
- B. Manual Air Vents:
 1. Body: Bronze.
 2. Internal Parts: Nonferrous.
 3. Operator: Screwdriver or thumbscrew.
 4. Inlet Connection: NPS 1/2.
 5. Discharge Connection: NPS 1/8.
 6. CWP Rating: 150 psig.
 7. Maximum Operating Temperature: 225 deg F.
- C. Automatic Air Vents:
 1. Body: Bronze or cast iron.
 2. Internal Parts: Nonferrous.
 3. Operator: Noncorrosive metal float.
 4. Inlet Connection: NPS 1/2.
 5. Discharge Connection: NPS 1/4.

6. CWP Rating: 150 psig.
7. Maximum Operating Temperature: 240 deg F.

D. Expansion Tanks:

1. Tank: Welded steel, rated for 125-psig working pressure and 375 deg F maximum operating temperature, with taps in bottom of tank for tank fitting and taps in end of tank for gage glass. Tanks shall be factory tested with taps fabricated and labeled according to ASME Boiler and Pressure Vessel Code: Section VIII, Division 1.
2. Air-Control Tank Fitting: Cast-iron body, copper-plated tube, brass vent tube plug, and stainless-steel ball check, 100-gal. unit only; sized for compression-tank diameter. Provide tank fittings for 125-psig working pressure and 250 deg F maximum operating temperature.
3. Tank Drain Fitting: Brass body, nonferrous internal parts; 125-psig working pressure and 240 deg F maximum operating temperature; constructed to admit air to compression tank, drain water, and close off system.
4. Gage Glass: Full height with dual manual shutoff valves, 3/4-inch diameter gage glass, and slotted-metal glass guard.

E. Bladder-Type Expansion Tanks:

1. Tank: Welded steel, rated for 125-psig working pressure and 375 deg F maximum operating temperature. Factory test with taps fabricated and supports installed and labeled according to ASME Boiler and Pressure Vessel Code: Section VIII, Division 1.
2. Bladder: Securely sealed into tank to separate air charge from system water to maintain required expansion capacity.
3. Air-Charge Fittings: Schrader valve, stainless steel with EPDM seats.

F. Tangential-Type Air Separators:

1. Tank: Welded steel; ASME constructed and labeled for 125-psig minimum working pressure and 375 deg F maximum operating temperature.
2. Air Collector Tube: Perforated stainless steel, constructed to direct released air into expansion tank.
3. Tangential Inlet and Outlet Connections: Threaded for NPS 2 and smaller; flanged connections for NPS 2-1/2 and larger.
4. Blowdown Connection: Threaded.
5. Size: Match system flow capacity.

G. In-Line Air Separators:

1. Tank: One-piece cast iron with an integral weir constructed to decelerate system flow to maximize air separation.
2. Maximum Working Pressure: Up to 175 psig.
3. Maximum Operating Temperature: Up to 300 deg F.

H. Air Purgers:

1. Body: Cast iron with internal baffles that slow the water velocity to separate the air from solution and divert it to the vent for quick removal.
2. Maximum Working Pressure: 150 psig.
3. Maximum Operating Temperature: 250 deg F.

2.7 CHEMICAL TREATMENT

- A. Bypass Chemical Feeder: Welded steel construction; 125-psig working pressure; 5-gal. capacity; with fill funnel and inlet, outlet, and drain valves.
1. Chemicals: Specially formulated, based on analysis of makeup water, to prevent accumulation of scale and corrosion in piping and connected equipment.
- B. Ethylene and Propylene Glycol: Industrial grade with corrosion inhibitors and environmental-stabilizer additives for mixing with water in systems indicated to contain antifreeze or glycol solutions.

2.8 HYDRONIC PIPING SPECIALTIES

A. Y-Pattern Strainers:

1. Body: ASTM A 126, Class B, ductile iron with bolted cover and bottom drain connection.
2. End Connections: Threaded ends for NPS 2 and smaller; flanged ends for NPS 2-1/2 and larger.
3. Strainer Screen: 4060-mesh startup strainer, and perforated stainless-steel basket with 50 percent free area.
4. CWP Rating: 125 psig.

B. Basket Strainers:

1. Body: ASTM A 126, Class B, high-tensile ductile iron with bolted cover and bottom drain connection.

2. End Connections: Threaded ends for NPS 2 and smaller; flanged ends for NPS 2-1/2 and larger.
3. Strainer Screen: 4060-mesh startup strainer, and perforated stainless-steel basket with 50 percent free area.
4. CWP Rating: 125 psig.

C. T-Pattern Strainers:

1. Body: Ductile or malleable iron with removable access coupling and end cap for strainer maintenance.
2. End Connections: Grooved ends.
3. Strainer Screen: 40-mesh startup strainer, and perforated stainless-steel basket with 57 percent free area.
4. CWP Rating: 750 psig.

D. Stainless-Steel Bellow, Flexible Connectors:

1. Body: Stainless-steel bellows with woven, flexible, bronze, wire-reinforcing protective jacket.
2. End Connections: Threaded or flanged to match equipment connected.
3. Performance: Capable of 3/4-inch misalignment.
4. CWP Rating: 150 psig.
5. Maximum Operating Temperature: 250 deg F.

E. Spherical, Rubber, Flexible Connectors (not for use in heating applications):

1. Body: Fiber-reinforced rubber body.
2. End Connections: Steel flanges drilled to align with Classes 150 and 300 steel flanges.
3. Performance: Capable of misalignment.
4. CWP Rating: 150 psig.
5. Maximum Operating Temperature: 60 deg F.

PART 3 - EXECUTION

3.1 PIPING APPLICATIONS

- A. Hot-water heating piping, aboveground, NPS 2 and smaller, shall be any of the following:
 - 1. Type L (B), drawn-temper copper tubing, wrought-copper fittings, and soldered joints.
 - 2. Schedule 40 steel pipe; Class 150, malleable-iron fittings; cast-iron flanges and flange fittings; and threaded joints.
- B. Hot-water heating piping, aboveground, NPS 2-1/2 and larger, shall be any of the following:
 - 1. Schedule 40 steel pipe, wrought-steel fittings and wrought-cast or forged-steel flanges and flange fittings, and welded and flanged joints.
- C. Chilled-water piping, aboveground, NPS 2 and smaller, shall be any of the following:
 - 1. Type L (B), drawn-temper copper tubing, wrought-copper fittings, and soldered pressure-seal joints.
 - 2. Schedule 40 steel pipe; Class 150, malleable-iron fittings; cast-iron flanges and flange fittings; and threaded joints.
- D. Chilled-water piping, aboveground, NPS 2-1/2 and larger, shall be any of the following:
 - 1. Schedule 40 steel pipe, wrought-steel fittings and wrought-cast or forged-steel flanges and flange fittings, and welded and flanged joints.
- E. Dual-temperature heating and cooling water piping, aboveground, NPS 2 and smaller, shall be any of the following:
 - 1. Type L (B), drawn-temper copper tubing, wrought-copper fittings, and soldered joints.
 - 2. Schedule 40 steel pipe; Class 150, malleable-iron fittings; cast-iron flanges and flange fittings; and threaded joints.
- F. Dual-temperature heating and cooling water piping, aboveground, NPS 2-1/2 and larger, shall be any of the following:
 - 1. Schedule 40 steel pipe, wrought-steel fittings and wrought-cast or forged-steel flanges and flange fittings, and welded and flanged joints.
- G. Dual-temperature heating and cooling water piping installed belowground and within slabs shall be either of the following:
 - 1. Underground Piping: Prefabricated, preinsulated conduit piping system. Carrier pipe to be Schedule 40, ASTM A53B ERW black steel. Insulation to be closed cell polyurethane foam

insulation and outer conduit shall be high density polyethylene (HDPE) jacket. Equal to either Xtru-Therm by Perma-Pipe or Ferro-Therm by Thermacor Process Inc.

- H. Condenser-water piping, aboveground, NPS 2 and smaller, shall be any of the following:
 - 1. Type L (B), drawn-temper copper tubing, wrought-copper fittings, and soldered joints.
 - 2. Schedule 40 steel pipe; Class 150, malleable-iron fittings; cast-iron flanges and flange fittings; and threaded joints.
- I. Condenser-water piping, aboveground, NPS 2-1/2 and larger, shall be any of the following:
 - 1. Schedule 40 steel pipe, wrought-steel fittings and wrought-cast or forged-steel flanges and flange fittings, and welded and flanged joints.
- J. Glycol cooling-water piping, aboveground, NPS 2 and smaller, shall be any of the following:
 - 1. Type L (B), drawn-temper copper tubing, wrought-copper fittings, and soldered joints.
 - 2. Schedule 40 steel pipe; Class 150, malleable-iron fittings; cast-iron flanges and flange fittings; and threaded joints.
- K. Glycol cooling-water piping, aboveground, NPS 2-1/2 and larger, shall be any of the following:
 - 1. Type L (B) M (C), drawn-temper copper tubing, wrought-copper fittings, and soldered brazed joints.
 - 2. Schedule 40 steel pipe, wrought-steel fittings and wrought-cast or forged-steel flanges and flange fittings, and welded and flanged joints.
- L. Makeup-water piping installed aboveground shall be either of the following:
 - 1. Type L (B), drawn-temper copper tubing, wrought-copper fittings, and soldered joints.
- M. Air Conditioning Condensate-Drain Piping: Type L, drawn-temper copper tubing, wrought-copper fittings, and soldered joints.
- N. Blowdown-Drain Piping: Same materials and joining methods as for piping specified for the service in which blowdown drain is installed.
- O. Air-Vent Piping:
 - 1. Inlet: Same as service where installed with metal-to-plastic transition fittings for plastic piping systems according to the piping manufacturer's written instructions.
 - 2. Outlet: Type K (A), annealed-temper copper tubing with soldered or flared joints.
- P. Safety-Valve-Inlet and -Outlet Piping for Hot-Water Piping: Same materials and joining methods as for piping specified for the service in which safety valve is installed with metal-to-plastic

transition fittings for plastic piping systems according to the piping manufacturer's written instructions.

1. Size piping to comply with manufacturers allowable back pressure requirements.

3.2 VALVE APPLICATIONS

- A. Install shutoff-duty valves at each branch connection to supply mains, and at supply connection to each piece of equipment.
- B. Install calibrated-orifice, balancing valves in the return pipe of each heating or cooling terminal where no PICV control valve is utilized. Circuit setters shall not be used for piping 2" and below.
- C. Install check valves at each pump discharge and elsewhere as required to control flow direction.
- D. Install safety valves at hot-water generators and elsewhere as required by ASME Boiler and Pressure Vessel Code. Install drip-pan elbow on safety-valve outlet and pipe without valves to the outdoors; and pipe drain to nearest floor drain or as indicated on Drawings. Comply with ASME Boiler and Pressure Vessel Code: Section VIII, Division 1, for installation requirements.
- E. Install pressure-reducing valves at makeup-water connection to regulate system fill pressure.

3.3 PIPING INSTALLATIONS

- A. Drawing plans, schematics, and diagrams indicate general location and arrangement of piping systems. Indicate piping locations and arrangements if such were used to size pipe and calculate friction loss, expansion, pump sizing, and other design considerations. Install piping as indicated unless deviations to layout are approved on Coordination Drawings.
- B. Install piping in concealed locations, unless otherwise indicated and except in equipment rooms and service areas.
- C. Install piping indicated to be exposed and piping in equipment rooms and service areas at right angles or parallel to building walls. Diagonal runs are prohibited unless specifically indicated otherwise.
- D. Install piping above accessible ceilings to allow sufficient space for ceiling panel removal.
- E. Install piping to permit valve servicing.
- F. Install piping at indicated slopes.
- G. Install piping free of sags and bends.
- H. Install fittings for changes in direction and branch connections.
- I. Install piping to allow application of insulation.

- J. Select system components with pressure rating equal to or greater than system operating pressure.
- K. Install groups of pipes parallel to each other, spaced to permit applying insulation and servicing of valves.
- L. Install drains, consisting of a tee fitting, NPS 3/4 ball valve, and short NPS 3/4 threaded nipple with cap, at low points in piping system mains and elsewhere as required for system drainage.
- M. Provide Vents at high points in system in addition to equipment as applicable.
- N. Install piping at a uniform grade of 0.2 percent upward in direction of flow.
- O. Reduce pipe sizes using eccentric reducer fitting installed with level side up.
- P. Install branch connections to mains using mechanically formed tee fittings in main pipe, with the branch connected to the bottom of the main pipe. For up-feed risers, connect the branch to the top of the main pipe.
- Q. Install valves according to Division 23 Section "General-Duty Valves for HVAC Piping."
- R. Install unions in piping, NPS 2 and smaller, adjacent to valves, at final connections of equipment, and elsewhere as indicated.
- S. Install flanges in piping, NPS 2-1/2 and larger, at final connections of equipment and elsewhere as indicated.
- T. Install strainers on inlet side of each control valve, pressure-reducing valve, solenoid valve, in-line pump, and elsewhere as indicated. Install NPS 3/4 nipple and ball valve in blowdown connection of strainers NPS 2 and larger. Match size of strainer blowoff connection for strainers smaller than NPS 2. Install the strainers so that the drain plugs can be removed, follow manufactures recommended installation requirements.
- U. Identify piping as specified in Division 23 Section "Identification for HVAC Piping and Equipment."

3.4 HANGERS AND SUPPORTS

- A. Hanger, support, and anchor devices are specified in Division 23 Section "Hangers and Supports for HVAC Piping and Equipment." Comply with the following requirements for maximum spacing of supports.
- B. Seismic restraints are specified in Division 23 Section "Vibration Controls for HVAC Equipment."
- C. Install the following pipe attachments:
 - 1. Adjustable steel clevis hangers for individual horizontal piping less than 20 feet long.

2. Adjustable roller hangers and spring hangers for individual horizontal piping 20 feet or longer.
 3. Pipe Roller: MSS SP-58, Type 44 for multiple horizontal piping 20 feet or longer, supported on a trapeze.
 4. Spring hangers to support vertical runs.
 5. Provide copper-clad hangers and supports for hangers and supports in direct contact with copper pipe.
 6. On plastic pipe, install pads or cushions on bearing surfaces to prevent hanger from scratching pipe.
- D. Install hangers for steel piping with the following maximum spacing and minimum rod sizes:
1. NPS 3/4: Maximum span, 7 feet; minimum rod size, 1/4 inch.
 2. NPS 1: Maximum span, 7 feet; minimum rod size, 1/4 inch.
 3. NPS 1-1/2: Maximum span, 9 feet; minimum rod size, 3/8 inch.
 4. NPS 2: Maximum span, 10 feet; minimum rod size, 3/8 inch.
 5. NPS 2-1/2: Maximum span, 11 feet; minimum rod size, 3/8 inch.
 6. NPS 3: Maximum span, 12 feet; minimum rod size, 3/8 inch.
 7. NPS 4: Maximum span, 14 feet; minimum rod size, 1/2 inch.
 8. NPS 6: Maximum span, 17 feet; minimum rod size, 1/2 inch.
 9. NPS 8: Maximum span, 19 feet; minimum rod size, 5/8 inch.
 10. NPS 10: Maximum span, 20 feet; minimum rod size, 3/4 inch.
 11. NPS 12: Maximum span, 23 feet; minimum rod size, 7/8 inch.
 12. NPS 14: Maximum span, 25 feet; minimum rod size, 1 inch.
 13. NPS 16: Maximum span, 27 feet; minimum rod size, 1 inch.
 14. NPS 18: Maximum span, 28 feet; minimum rod size, 1-1/4 inches.
 15. NPS 20: Maximum span, 30 feet; minimum rod size, 1-1/4 inches.
- E. Install hangers for drawn-temper copper piping with the following maximum spacing and minimum rod sizes:
1. NPS 3/4: Maximum span, 5 feet; minimum rod size, 1/4 inch.

2. NPS 1: Maximum span, 6 feet; minimum rod size, 1/4 inch.
 3. NPS 1-1/2: Maximum span, 8 feet; minimum rod size, 3/8 inch.
 4. NPS 2: Maximum span, 8 feet; minimum rod size, 3/8 inch.
 5. NPS 2-1/2: Maximum span, 9 feet; minimum rod size, 3/8 inch.
 6. NPS 3: Maximum span, 10 feet; minimum rod size, 3/8 inch.
- F. Support vertical runs at roof, at each floor, and at 10-foot intervals between floors.

3.5 PIPE JOINT CONSTRUCTION

- A. Join pipe and fittings according to the following requirements and Division 23 Sections specifying piping systems.
- B. Ream ends of pipes and tubes and remove burrs. Bevel plain ends of steel pipe.
- C. Remove scale, slag, dirt, and debris from inside and outside of pipe and fittings before assembly.
- D. Soldered Joints: Apply ASTM B 813, water-flushable flux, unless otherwise indicated, to tube end. Construct joints according to ASTM B 828 or CDA's "Copper Tube Handbook," using lead-free solder alloy complying with ASTM B 32.
- E. Brazed Joints: Construct joints according to AWS's "Brazing Handbook," "Pipe and Tube" Chapter, using copper-phosphorus brazing filler metal complying with AWS A5.8.
 1. Apply appropriate tape or thread compound to external pipe threads unless dry seal threading is specified.
 2. Damaged Threads: Do not use pipe or pipe fittings with threads that are corroded or damaged. Do not use pipe sections that have cracked or open welds.
- F. Welded Joints: Construct joints according to AWS D10.12/D10.12M, using qualified processes and welding operators according to Part 1 "Quality Assurance" Article.
- G. Flanged Joints: Select appropriate gasket material, size, type, and thickness for service application. Install gasket concentrically positioned. Use suitable lubricants on bolt threads.
- H. Grooved Joints: Assemble joints with coupling and gasket, lubricant, and bolts. Cut or roll grooves in ends of pipe based on pipe and coupling manufacturer's written instructions for pipe wall thickness. Use grooved-end fittings and rigid, grooved-end-pipe couplings.
- I. Mechanically Formed, Copper-Tube-Outlet Joints: Use manufacturer-recommended tool and procedure, and brazed joints.
- J. Pressure-Sealed Joints: Use manufacturer-recommended tool and procedure. Leave insertion marks on pipe after assembly.

3.6 HYDRONIC SPECIALTIES INSTALLATION

- A. Install manual air vents at high points in piping, at heat-transfer coils, and elsewhere as required for system air venting.
- B. Install automatic air vents at high points of system piping in mechanical equipment rooms only. Manual vents at heat-transfer coils and elsewhere as required for air venting.
- C. Install piping from boiler air outlet, air separator, or air purger to expansion tank with a 2 percent upward slope toward tank.
- D. Install in-line air separators in pump suction. Install drain valve on air separators NPS 2 and larger.
- E. Install tangential air separator in pump suction. Install blowdown piping with gate or full-port ball valve; extend full size to nearest floor drain.
- F. Install bypass chemical feeders in each hydronic system where indicated, in upright position with top of funnel not more than 48 inches above the floor. Install feeder in minimum NPS 3/4 bypass line, from main with full-size, full-port, ball valve in the main between bypass connections. Install NPS 3/4 pipe from chemical feeder drain, to nearest equipment drain and include a full-size, full-port, ball valve.
- G. Install expansion tanks above the air separator. Install tank fitting in tank bottom and charge tank. Use manual vent for initial fill to establish proper water level in tank.
 - 1. Install tank fittings that are shipped loose.
 - 2. Support tank from floor or structure above with sufficient strength to carry weight of tank, piping connections, fittings, plus tank full of water. Do not overload building components and structural members.
- H. Install expansion tanks on the floor. Vent and purge air from hydronic system, and ensure tank is properly charged with air to suit system Project requirements.

3.7 TERMINAL EQUIPMENT CONNECTIONS

- A. Sizes for supply and return piping connections shall be the same as or larger than equipment connections.
- B. Install control valves in accessible locations close to connected equipment.
- C. Install bypass piping with globe valve around control valve. If parallel control valves are installed, only one bypass is required.
- D. Install ports for pressure gages and thermometers at coil inlet and outlet connections according to Division 23 Section "Meters and Gages for HVAC Piping."

3.8 CHEMICAL TREATMENT

- A. Refer to 232500 - HVAC Water Treatment Spec.

3.9 GLYCOL

- A. Fill systems indicated to have antifreeze or glycol solutions with the following concentrations (refer to Dwgs on glycol %)
 - 1. Hot-Water Heating Piping: Minimum 30/35 percent ethylene glycol.
 - 2. Chilled-Water Piping: Minimum 30/35 percent ethylene glycol.
 - 3. Dual-Temperature Heating and Cooling Water Piping: Minimum 30/35 percent ethylene glycol.
 - 4. Glycol Cooling-Water Piping: Minimum 30/35 percent ethylene glycol.

3.10 FIELD QUALITY CONTROL

- A. Prepare hydronic piping according to ASME B31.9 and as follows:
 - 1. Leave joints, including welds, uninsulated and exposed for examination during test.
 - 2. Provide temporary restraints for expansion joints that cannot sustain reactions due to test pressure. If temporary restraints are impractical, isolate expansion joints from testing.
 - 3. Isolate equipment from piping. If a valve is used to isolate equipment, its closure shall be capable of sealing against test pressure without damage to valve. Install blinds in flanged joints to isolate equipment.
 - 4. Install safety valve, set at a pressure no more than one-third higher than test pressure, to protect against damage by expanding liquid or other source of overpressure during test.
 - 5. Pressure Gauges used to verify pressure shall be:
 - a. Dial Range: 10 psi above test pressure
 - b. Major Increment: 20 psi
 - c. Minor Increment: 2 psi
- B. Pipe Flushing
 - 1. Refer to Section 232500 – HVAC Water Treatment
- C. Perform the following tests on hydronic piping:

1. Use ambient temperature water as a testing medium unless there is risk of damage due to freezing. Another liquid that is safe for workers and compatible with piping may be used.
2. While filling system, use vents installed at high points of system to release air. Use drains installed at low points for complete draining of test liquid.
3. Isolate expansion tanks and determine that hydronic system is full of water.
4. Subject piping system to hydrostatic test pressure that is not less than 1.5 times the system's working pressure for 24 hours. Test pressure shall not exceed maximum pressure for any vessel, pump, valve, or other component in system under test. Verify that stress due to pressure at bottom of vertical runs does not exceed 90 percent of specified minimum yield strength or 1.7 times "SE" value in Appendix A in ASME B31.9, "Building Services Piping."
5. After hydrostatic test pressure has been applied for at least 10 minutes, examine piping, joints, and connections for leakage. Eliminate leaks by tightening, repairing, or replacing components, and repeat hydrostatic test until there are no leaks.
6. All piping joints shall be leak tested prior to being put in service. Prepare written report of testing.

D. Perform the following before operating the system:

1. Open manual valves fully.
2. Inspect pumps for proper rotation.
3. Set makeup pressure-reducing valves for required system pressure.
4. Inspect air vents at high points of system and determine if all are installed and operating freely (automatic type), or bleed air completely (manual type).
5. Set temperature controls so all coils are calling for full flow.
6. Inspect and set operating temperatures of hydronic equipment, such as boilers, chillers, cooling towers, to specified values.
7. Verify lubrication of motors and bearings.
8. Determine the pressure rating for all connected fittings and devices to ensure they are rated for the maximum test pressure.

END OF SECTION 232113

SECTION 232123 - HYDRONIC PUMPS

PART 1 - GENERAL

1.1 RELATED DOCUMENTS

- A. Drawings and general provisions of the Contract, including General and Supplementary Conditions and Division 01 Specification Sections, apply to this Section.

1.2 SUMMARY

- A. Section Includes:
 - 1. Close-coupled, in-line centrifugal pumps.
 - 2. Close-coupled, end-suction centrifugal pumps.

1.3 DEFINITIONS

- A. ECM: Electronically commutated motor.
- B. EPDM: Ethylene propylene diene monomer.
- C. EPR: Ethylene propylene rubber.
- D. FKM: Fluoroelastomer polymer.
- E. HI: Hydraulic Institute.
- F. NBR: Nitrile rubber or Buna-N.

1.4 ACTION SUBMITTALS

- A. Product Data: For each type of pump.
 - 1. Include certified performance curves and rated capacities, operating characteristics, furnished specialties, final impeller dimensions, and accessories for each type of product indicated.
 - 2. Indicate pump's operating point on curves.
- B. Shop Drawings: For each pump.
 - 1. Show pump layout and connections.
 - 2. Include setting drawings with templates for installing foundation and anchor bolts and other anchorages.
 - 3. Include diagrams for power, signal, and control wiring.

1.5 INFORMATIONAL SUBMITTALS

- A. Coordination Drawings: Plans, or BIM model, drawn to scale, showing the items described in this Section, and coordinated with all building trades.
- B. Each pump shall be factory tested per Hydraulic Institute standards prior to shipment and shall conform to ANSI/HI 1.1 -1.5 1994 section 1.4.6.1.1 for recommended acceptable unfiltered field vibration limits.

1.6 CLOSEOUT SUBMITTALS

- A. Operation and Maintenance Data: For pumps to include in emergency, operation, and maintenance manuals. Include assembly views, lubrication instructions and replacement parts list.
- B. Field quality-control reports.
- C. System Start-Up Reports

1.7 MAINTENANCE MATERIAL SUBMITTALS

- A. Furnish extra materials that match products installed and that are packaged with protective covering for storage and identified with labels describing contents.
 - 1. Mechanical Seals: One mechanical seal(s) for each pump.

PART 2 - PRODUCTS

2.1 GENERAL REQUIREMENTS

- A. Electrical Components, Devices, and Accessories: Listed and labeled as defined in NFPA 70, by a qualified testing agency, and marked for intended location and application.
- B. Balance: Rotating parts, statically and dynamically.
- C. Construction: To permit servicing without breaking piping and motor connections.
- D. Material: Where option is given, select compatible materials.
- E. Pump Motors:
 - 1. Operate at 1750 rpm unless specified otherwise.
 - 2. Motor shall not be smaller than scheduled.
 - 3. Pumps controlled by variable frequency drives shall have motors conforming to requirements of drive manufacturer.
- F. Actual pump performance shall not vary more than plus or minus 3 percent of submitted flow/head/efficiency data at specified system fluid temperatures, without vapor binding or cavitation.

2.2 END SUCTION PUMPS

- A. Bell & Gossett, Armstrong & Aurora (Bell & Gossett 1510 Basis of Design).
- B. Pumps shall be base-mounted, single stage, end suction design.
- C. Pump volute shall be made of ductile iron with integrally cast pedestal support. The impeller shall be cast bronze, enclosed type, statically and hydraulically balanced.
- D. Impeller shall be keyed to the shaft and secured by a hex head impeller nut and washer.
- E. Pumps shall be provided with a single inside unbalanced mechanical shaft seal for leakless operation. A suitable arrangement shall be provided to furnish a portion of the pumped liquid to lubricate and cool the seal faces.
- F. Pump shall be rated for a minimum of 175 psi working pressure.
- G. Casings shall be provided with tapped and plugged holes for priming, vent, and drain.
- H. Pump bearing housing shall have heavy duty regreasable ball bearings.
- I. Baseplate shall be channel steel, sufficiently rigid to support the pump and driving motor.
- J. A flexible-type coupler, capable of absorbing torsional vibration, shall be employed between the pump and motor, and it shall be equipped with a suitable coupling guard as required.
- K. Contractor to level and grout each unit according to manufacturer's instructions.
- L. The motor shall be NEMA specifications and shall be the size, voltage and enclosure called for on the plans. Pump and motor shall be factory aligned, and shall be realigned by contractor after installation.
- M. Each pump shall be factory tested. It shall then be thoroughly cleaned and painted with at least one coat of high grade machinery enamel prior to shipment.
- N. Each pump shall be checked by the contractor and regulated for proper differential pressure, voltage and amperage draw.
- O. This data shall be noted on a permanent tag or label and fastened to the pump for owner's reference.

2.3 SUCTION DIFFUSER

- A. For each pump, furnish an angle body suction diffuser, sized for minimal pressure drop for pump design operating flow.
- B. The orifice cylinder shall be designed to withstand pressure differential equal to the pump shutoff head (maximum 40 PSI) and shall have a free area equal to five times the cross section area of the pump suction opening.

- C. The length of the flow straightening vanes shall be no less than 2½ times the diameter of the system pump suction connection.
- D. The suction diffuser shall be of cast iron construction with 3" NPT system and 2" NPT pump connections. The diffuser shall have a steel combination diffuser-strainer-orifice cylinder with 3/16" diameter openings to protect the pump.
- E. The full length steel flow straightening vanes shall provide non-turbulent flow to the suction side of the pump.
- F. The orifice cylinder shall be equipped with a disposable fine mesh strainer which shall be removed after system start-up.
- G. Unit shall be provided with an adjustable support foot to eliminate pipe strain at the suction diffuser/pump connection.
- H. Each flow straightening fitting is to be equal to Bell & Gossett Model No. DB-3 suction diffuser.

2.4 IN-LINE CENTRIFUGAL PUMPS

- A. Manufacturers: Bell and Gossett, Taco, Armstrong, Weinmann or Aurora.
- B. Pumps shall be pipeline mounted, single suction type with cast iron casing, bronze fitted with working pressure of 175 psi and continuous operating temperature suitable to their application as specified herein.
- C. Casings shall have tapped and plugged openings for vent, drain, and suction and discharge gauge connections.
- D. Impellers to be single suction enclosed type made of bronze, hydraulically and dynamically balanced, keyed and locked to pump shafts and protected by replaceable bronze shaft sleeves.
- E. Impellers shall be directly hung from motor shafts without using flexible couplings.
- F. Pump shafts shall be high strength carbon steel or alloy steel, sealed and gasketed from pumped fluid.
- G. Hot water pumps shall be furnished with mechanical seals of single unbalanced type with carbon rotating faces, ceramic stationary seats and EPR elastomer rated up to 250°F continuous operation.
- H. Bearing assemblies and motors shall have oil lubricated sleeve bearings or regreasable ball bearings.

2.5 PUMP SPECIALTY FITTINGS

- A. Triple-Duty Valve:
 - 1. Triple-Duty Valves shall not be used.

PART 3 - EXECUTION

3.1 EXAMINATION

- A. Examine equipment foundations and anchor-bolt locations for compliance with requirements for installation tolerances and other conditions affecting performance of the Work.
- B. Examine roughing-in for piping systems to verify actual locations of piping connections before pump installation.
- C. Examine foundations and inertia bases for suitable conditions where pumps will be installed.
- D. Proceed with installation only after unsatisfactory conditions have been corrected.

3.2 PUMP INSTALLATION

- A. Comply with HI 1.4.
- B. Install pumps to provide access for periodic maintenance including removing motors, impellers, couplings, and accessories.
- C. Independently support pumps and piping so weight of piping is not supported by pumps and weight of pumps is not supported by piping.
- D. Automatic Condensate Pump Units: Install units for collecting condensate and extend to open drain.
- E. Equipment Mounting:
 - 1. Install base-mounted pumps on cast-in-place concrete equipment bases. Comply with requirements for equipment bases and foundations specified in Section 033000 "Cast-in-Place Concrete."
 - 2. Comply with requirements for vibration isolation and seismic-control devices specified in Section 230548 "Vibration and Seismic Controls for HVAC."
 - 3. Comply with requirements for vibration isolation devices specified in Section 230548.13 "Vibration Controls for HVAC."
- F. Equipment Mounting: Install in-line pumps with continuous-thread hanger rods and elastomeric hangers of size required to support weight of in-line pumps.
 - 1. Comply with requirements for seismic-restraint devices specified in Section 230548 "Vibration and Seismic Controls for HVAC."
 - 2. Comply with requirements for hangers and supports specified in Section 230529 "Hangers and Supports for HVAC Piping and Equipment."

3.3 ALIGNMENT

- A. Engage a factory-authorized service representative to perform alignment service.

- B. Perform alignment service. When required by manufacturer to maintain warranty coverage, engage a factory-authorized service representative to perform it.
- C. Comply with requirements in HI standards for alignment of pump and motor shaft. Add shims to the motor feet and bolt motor to base frame. Do not use grout between motor feet and base frame.
- D. Comply with pump and coupling manufacturers' written instructions.
- E. After alignment is correct, tighten foundation bolts evenly but not too firmly. Completely fill baseplate with nonshrink, nonmetallic grout while metal blocks and shims or wedges are in place. After grout has cured, fully tighten foundation bolts.

3.4 PIPING CONNECTIONS

- A. Comply with requirements for piping specified in Section 232213 "Steam and Condensate Heating Piping" and Section 232216 "Steam and Condensate Piping Specialties." Drawings indicate general arrangement of piping, fittings, and specialties.
- B. Where installing piping adjacent to pump, allow space for service and maintenance.
- C. Connect piping to pumps. Install valves that are same size as piping connected to pumps.
- D. Install suction and discharge pipe sizes equal to or greater than diameter of pump nozzles.
- E. Install check, shutoff, on discharge side of pumps; throttling valves shall be eliminated for systems with Variable Speed Drives..
- F. Install suction diffuser and shutoff valve on suction side of pumps.
 - 1. Use startup strainer for initial system startup. Install permanent strainer element before turnover of system to Owner.
- G. Install flexible connectors on suction and discharge sides of base-mounted pumps between pump casing and valves.
- H. Install pressure gauges on pump suction and discharge or at integral pressure-gauge tapping, or install single gauge with multiple-input selector valve.
- I. Install check valve on each condensate pump unit discharge unless unit has a factory-installed check valve.

3.5 ELECTRICAL CONNECTIONS

- A. Connect wiring in accordance with Section 260519 "Low-Voltage Electrical Power Conductors and Cables."
- B. Ground equipment in accordance with Section 260526 "Grounding and Bonding for Electrical Systems."

- C. Install electrical devices furnished by manufacturer, but not factory mounted, in accordance with NFPA 70 and NECA 1.
- D. Install nameplate for each electrical connection, indicating electrical equipment designation and circuit number feeding connection.
 - 1. Nameplate shall be laminated acrylic or melamine plastic signs, as specified in Section 260553 "Identification for Electrical Systems."
 - 2. Nameplate shall be laminated acrylic or melamine plastic signs with a black background and engraved white letters at least 1/2 inch high.

3.6 CONTROL CONNECTIONS

- A. Install control and electrical power wiring to field-mounted control devices.
- B. Connect control wiring in accordance with Section 260523 "Control-Voltage Electrical Power Cables."

3.7 STARTUP SERVICE

- A. Engage a factory-authorized service representative to perform startup service.
 - 1. Complete installation and startup checks in accordance with manufacturer's written instructions.
 - 2. Check piping connections for tightness.
 - 3. Clean strainers on suction piping. Use startup strainer for initial startup.
 - 4. Perform the following startup checks for each pump before starting:
 - a. Verify bearing lubrication.
 - b. Verify that pump is free to rotate by hand and that pump for handling hot liquid is free to rotate with pump hot and cold. If pump is bound or drags, do not operate until cause of trouble is determined and corrected.
 - c. Verify that pump is rotating in correct direction.
 - 5. Prime pump by opening suction valves and closing drains, and prepare pump for operation.
 - 6. Start motor.
 - 7. Open discharge valve slowly.

3.8 FIELD QUALITY CONTROL

- A. Testing Agency: Engage a qualified testing agency to perform tests and inspections.
- B. Manufacturer's Field Service: Engage a factory-authorized service representative to test and inspect components, assemblies, and equipment installations, including connections.
- C. Perform tests and inspections

- D. Hydronic pumps will be considered defective if they do not pass tests and inspections.
- E. Prepare test and inspection reports.

3.9 DEMONSTRATION

- A. Train Owner's maintenance personnel to adjust, operate, and maintain hydronic pumps.

END OF SECTION 232123

SECTION 232213 - STEAM AND CONDENSATE HEATING PIPING

PART 1 - GENERAL

1.1 RELATED DOCUMENTS

- A. Drawings and general provisions of the Contract, including General and Supplementary Conditions and Division 01 Specification Sections, apply to this Section.

1.2 SUMMARY

- A. Section includes pipe and fittings for LP and HP steam and condensate piping:
 - 1. Steel pipe and fittings.
 - 2. Joining materials.
- B. Related Requirements:
 - 1. Section 232216 "Steam and Condensate Heating Piping Specialties" for strainers, flash tanks, special-duty valves, steam traps, thermostatic air vents and vacuum breakers, and steam and condensate meters.

1.3 ACTION SUBMITTALS

- A. Product Data: For each type of the following:
 - 1. Steel pipe and fitting.
 - 2. Joining material.

1.4 INFORMATIONAL SUBMITTALS

- A. Coordination Drawings: Piping layout, drawn to scale, on which the following items are shown and coordinated with each other, using input from installers of the items involved:
 - 1. Suspended ceiling components.
 - 2. Other building services.
 - 3. Structural members.
- B. Qualification Data: For Installer.
- C. Welding certificates.
- D. Field quality-control reports.

1.5 QUALITY ASSURANCE

- A. Installer Qualifications:
- B. Steel Support Welding: Qualify procedures and personnel according to AWS D1.1/D1.1M, "Structural Welding Code - Steel."
- C. Delegated-Design Submittal:
 - 1. Design calculations and detailed fabrication and assembly of pipe anchors and alignment guides, hangers and supports for multiple pipes, expansion joints and loops, and attachments of the same to the building structure. Professional Engineering stamp required for anchors and expansion loops.
 - 2. Locations of pipe anchors and alignment guides and expansion joints and loops.
 - 3. Locations of and details for penetrations, including sleeves and sleeve seals for exterior walls, floors, basement, and foundation walls.
 - 4. Locations of and details for penetration and firestopping for fire- and smoke-rated wall and floor and ceiling assemblies.
- D. Pipe Welding: Qualify procedures and operators according to the following:
 - 1. ASME Compliance: Comply with ASME B31.1, "Power Piping," for materials, products, and installation for Steam piping.
 - 2. Certify that each welder has passed AWS qualification tests for welding processes involved and that certification is current.

PART 2 - PRODUCTS

2.1 PERFORMANCE REQUIREMENTS

- A. Components and installation shall be capable of withstanding the following minimum working pressures and temperatures unless otherwise indicated:
 - 1. HP Steam Piping: >100 psig.
 - 2. LP Steam Piping: \leq 100 psig.
 - 3. Condensate Piping: 80 psig at 250 deg F.
 - 4. Makeup-Water Piping: 80 psig at 150 deg F.
 - 5. Blowdown-Drain Piping: Equal to pressure of the piping system to which it is attached.
 - 6. Air-Vent and Vacuum-Breaker Piping: Equal to pressure of the piping system to which it is attached.
 - 7. Safety-Valve-Inlet and -Outlet Piping: Equal to pressure of the piping system to which it is attached.

2.2 STEEL PIPE AND FITTINGS

- A. Steel Pipe: ASTM A 53/A 53M, black steel, plain ends, welded and seamless, Grade B, and Schedule as indicated in piping applications articles.

- B. Cast-Iron Threaded Fittings: ASME B16.4; Classes 125, 150, and 300 as indicated in piping applications articles.
- C. Malleable-Iron Threaded Fittings: ASME B16.3; Classes 150 and 300 as indicated in piping applications articles.
- D. Malleable-Iron Unions: ASME B16.39; Classes 150, 250, and 300 as indicated in piping applications articles.
- E. Cast-Iron Threaded Flanges and Flanged Fittings: ASME B16.1, Classes 125 and 250 as indicated in piping applications articles; raised ground face, and bolt holes spot faced.
- F. Wrought-Steel Fittings: ASTM A 234/A 234M, wall thickness to match adjoining pipe.
- G. Wrought-Steel Flanges and Flanged Fittings: ASME B16.5, including bolts, nuts, and gaskets of the following material group, end connections, and facings:
 - 1. Material Group: 1.1.
 - 2. End Connections: Butt welding.
 - 3. Facings: Raised face.
- H. Steel Pipe Nipples: ASTM A 733, made of ASTM A 53/A 53M, black steel of same Type, Grade, and Schedule as pipe in which installed.

2.3 JOINING MATERIALS

- A. Pipe-Flange Gasket Materials: Suitable for chemical and thermal conditions of piping system contents.
 - 1. ASME B16.21, nonmetallic, flexible graphite spiral wound metal gasket (flextalic), asbestos free, 1/8-inch maximum thickness unless otherwise indicated.
 - a. Full-Face Type: For flat-face, Class 125, cast-iron and cast-bronze flanges.
 - b. Narrow-Face Type: For raised-face, Class 250, cast-iron and steel flanges.
- B. Flange Bolts: Stud bolts, ASTM A193, Gr. B7.
- C. Flange Nuts: ASTM A194, Gr.2H.
- D. Welding Filler Metals: Comply with AWS D10.12M/D10.12 for welding materials appropriate for wall thickness and chemical analysis of steel pipe being welded.
- E. Welding Materials: Comply with Section II, Part C, of ASME Boiler and Pressure Vessel Code for welding materials appropriate for wall thickness and for chemical analysis of pipe being welded.

PART 3 - EXECUTION

3.1 LP STEAM PIPING APPLICATIONS

- A. LP Steam Piping, NPS 1 and Smaller Schedule 40, Type S, Grade B, steel pipe; Class 125 cast-iron fittings; and threaded joints.
- B. LP Steam Piping, NPS 1-1/2 and larger: Schedule 40, Type E, Grade B, steel pipe; Class 150 wrought-steel fittings, flanges, and flange fittings; and welded and flanged joints.
- C. LP Steam Piping, NPS 1-1/2 and larger: Schedule 40, Type S, Grade B, steel pipe; Class wrought-steel fittings, flanges, and flange fittings; and welded and flanged joints.
- D. Condensate piping above grade, NPS 2 and smaller, shall be the following:
 - 1. Schedule 80, Type S, Grade B, steel pipe; Class 125 cast-iron fittings; and threaded joints.
- E. Condensate piping above grade, NPS 2-1/2 and larger, shall be the following:
 - 1. Schedule 80, Type E, Grade B, steel pipe; Class 150 wrought-steel fittings, flanges, and flange fittings; and welded and flanged joints.
- F. Pumped Condensate piping shall be the following:
 - 1. Schedule 80, Type S, Grade B, steel pipe; Class 150 wrought-steel fittings welded joints.
- G. Condensate piping below grade, NPS 2 and smaller, shall be the following:
 - 1. Schedule 80, Type S, Grade B, steel pipe; Class 125 cast-iron fittings; and threaded joints.
- H. Condensate piping below grade, NPS 2-1/2 and larger, shall be the following:
 - 1. Schedule 80, Type E, Grade B, steel pipe; Class 150 wrought-steel fittings, flanges, and flange fittings; and welded and flanged joints.

3.2 HP STEAM PIPING APPLICATIONS

- A. HP Steam Piping, NPS 2 and Smaller: Schedule 40, Type S, Grade B, steel pipe; Class 300 cast-iron fittings; and threaded joints.
- B. HP Steam Piping, NPS 2-1/2 and larger: Schedule 40, Type E, Grade B, steel pipe; Class 300 wrought-steel fittings, flanges, and flange fittings; and welded and flanged joints.
- C. HP Steam Piping, NPS 20 and Larger: Schedule 20, Type E, Grade B, steel pipe; Class 300 wrought-steel fittings, flanges, and flange fittings; and welded and flanged joints.
- D. Condensate piping above grade, NPS 2 and smaller, shall be the following:

1. Schedule 80, Type S, Grade B, steel pipe; Class 125 cast-iron fittings; and threaded joints.
- E. Condensate piping above grade, NPS 2-1/2 and larger, shall be the following:
 1. Schedule 80, Type E, Grade B, steel pipe; Class 150 wrought-steel fittings, flanges, and flange fittings; and welded and flanged joints.
- F. Condensate piping below grade, NPS 2 and smaller, shall be the following:
 1. Schedule 80, Type S, Grade B, steel pipe; Class 125 cast-iron fittings; and threaded joints.
- G. Condensate piping below grade, NPS 2-1/2 and larger, shall be the following:
 1. Schedule 80, Type E, Grade B, steel pipe; Class 150 wrought-steel fittings, flanges, and flange fittings; and welded and flanged joints.

3.3 ANCILLARY PIPING APPLICATIONS

- A. Blowdown-Drain Piping: Same materials and joining methods as for piping specified for the service in which blowdown drain is installed.
- B. Vacuum-Breaker Piping: Outlet, same as service where installed.
- C. Safety-Valve-Inlet and -Outlet Piping: Same materials and joining methods as for piping specified for the service in which safety valve is installed.

3.4 PIPING INSTALLATION

- A. Drawing plans, schematics, and diagrams indicate general location and arrangement of piping systems. Install piping as indicated unless deviations to layout are approved on Coordination Drawings.
- B. Install piping in concealed locations unless otherwise indicated and except in equipment rooms and service areas.
- C. Install piping indicated to be exposed and piping in equipment rooms and service areas at right angles or parallel to building walls. Diagonal runs are prohibited unless otherwise indicated.
- D. Install piping above accessible ceilings to allow sufficient space for ceiling panel removal.
- E. Install piping to permit valve servicing.
- F. Install piping free of sags and bends.
- G. Install fittings for changes in direction and branch connections.
- H. Install piping to allow application of insulation.

- I. Select system components with pressure rating equal to or greater than system operating pressure.
- J. Install groups of pipes parallel to each other, spaced to permit applying insulation and servicing of valves.
- K. Install drains, consisting of a tee fitting, NPS 3/4 full port-ball valve, and short NPS 3/4 threaded nipple with cap, at low points in piping system mains and elsewhere as required for system drainage.
- L. Install steam supply piping at a minimum uniform grade of 0.2 percent downward in direction of steam flow.
- M. Install condensate return piping at a minimum uniform grade of 0.4 percent downward in direction of condensate flow.
- N. Reduce pipe sizes using eccentric reducer fitting installed with level side down.
- O. Install branch connections to mains using mechanically formed tee fittings in main pipe, with the branch connected to top of main pipe.
- P. Install valves according to the following Sections or other Sections as needed:
 - 1. Section 230523 "Valves for HVAC Piping."
- Q. Install unions in piping, NPS 2 and smaller, adjacent to valves, at final connections of equipment, and elsewhere as indicated.
- R. Install flanges in piping, NPS 2-1/2 and larger, at final connections of equipment and elsewhere as indicated.
- S. Install strainers on supply side of control valves, pressure-reducing valves, traps, and elsewhere as indicated. Install NPS 3/4 nipple and full port ball valve in blowdown connection of strainers NPS 2 and larger. Match size of strainer blowoff connection for strainers smaller than NPS 2.
- T. Comply with requirements in Section 230516 "Expansion Fittings and Loops for HVAC Piping" for installation of expansion loops, expansion joints, anchors, and pipe alignment guides.
- U. Comply with requirements in Section 230553 "Identification for HVAC Piping and Equipment" for identifying piping.
- V. Install drip legs at low points and natural drainage points such as ends of mains, bottoms of risers, and ahead of pressure regulators, and control valves.
 - 1. On straight runs with no natural drainage points, install drip legs at intervals not exceeding 300 feet.
 - 2. Size drip legs same size as main. In steam mains NPS 6 and larger, drip leg size can be reduced, but to no less than NPS 4.

3.5 STEAM AND CONDENSATE PIPING SPECIALTIES INSTALLATION

- A. Comply with requirements in Section 232216 "Steam and Condensate Heating Piping Specialties" for installation requirements for strainers, flash tanks, special-duty valves, steam traps, thermostatic air vents and vacuum breakers, and steam and condensate meters.

3.6 INSTALLATION OF HANGERS AND SUPPORTS

- A. Comply with requirements for seismic restraints in Section 230548 "Vibration and Seismic Controls for HVAC."
- B. Comply with requirements in Section 230529 "Hangers and Supports for HVAC Piping and Equipment" for installation of hangers, supports, and anchor devices.
- C. Install the following pipe attachments:
 - 1. Adjustable steel clevis hangers for individual horizontal piping less than 20 feet long.
 - 2. Adjustable roller hangers and spring hangers for individual horizontal piping 20 feet or longer.
 - 3. Pipe Roller: MSS SP-58, Type 44 for multiple horizontal piping 20 feet or longer, supported on a trapeze.
 - 4. Spring hangers to support vertical runs.
- D. Install hangers for steel steam supply piping and steel steam condensate piping, with maximum horizontal spacing and minimum rod diameters, to comply with MSS-58, locally enforced codes, and authorities having jurisdiction requirements, whichever are most stringent.
- E. Support horizontal piping within 12 inches of each fitting.
- F. Support vertical runs of steel steam supply piping and steel steam condensate piping to comply with MSS-58, locally enforced codes, and authorities having jurisdiction requirements, whichever are most stringent.

3.7 PIPE JOINT CONSTRUCTION

- A. Ream ends of pipes and remove burrs. Bevel plain ends of steel pipe.
- B. Remove scale, slag, dirt, and debris from inside and outside of pipe and fittings before assembly.
- C. Threaded Joints: Thread pipe with tapered pipe threads according to ASME B1.20.1. Cut threads full and clean using sharp dies. Ream threaded pipe ends to remove burrs and restore full ID. Join pipe fittings and valves as follows:

1. Apply appropriate tape or thread compound to external pipe threads unless dry seal threading is specified.
 2. Damaged Threads: Do not use pipe or pipe fittings with threads that are corroded or damaged. Do not use pipe sections that have cracked or open welds.
- D. Welded Joints: Construct joints according to AWS D10.12M/D10.12, using qualified processes and welding operators according to "Quality Assurance" Article.
- E. Flanged Joints: Select appropriate gasket material, size, type, and thickness for service application. Install gasket concentrically positioned. Use suitable lubricants on bolt threads.

3.8 TERMINAL EQUIPMENT CONNECTIONS

- A. Size for supply and return piping connections shall be the same as or larger than equipment connections.
- B. Install traps and control valves in accessible locations close to connected equipment.
- C. Install bypass piping with globe valve around control valve. If parallel control valves are installed, only one bypass is required.
- D. Install vacuum breakers downstream from control valve, close to coil inlet connection.
- E. Install a drip leg at coil outlet.

3.9 FIELD QUALITY CONTROL

- A. Prepare steam and condensate piping according to ASME B31.1, "Power Piping," and as follows:
1. Leave joints, including welds, uninsulated and exposed for examination during test.
 2. Provide temporary restraints for expansion joints that cannot sustain reactions due to test pressure. If temporary restraints are impractical, isolate expansion joints from testing.
 3. Clean strainers.
 4. Isolate equipment from piping. If a valve is used to isolate equipment, its closure shall be capable of sealing against test pressure without damage to valve. Install blinds in flanged joints to isolate equipment.
- B. Flush system with a combination of compressed air and steam.
1. Isolate all equipment from piping system with valves or blind flanges, including flash tank, heat exchangers and condensate return units. Provide temporary piping and spool pieces as required to properly flush, clean and vent air/steam safely to the outdoors.
 2. Provide spool pieces at equipment subject to damage or clogging during flushing. Devices include but are not limited to.
 - a. Pressure reducing valves
 - b. In-line and vortex flow meters
 - c. Control Valves
 - d. Steam Traps

- e. Gauges and Sensors
 3. Flush pressure shall not exceed the specified working pressure of the system. Compressed air shall be minimum of 100 PSI.
 4. The initial flush shall be with compressed air. Strainers shall be removed during the initial flush and the strainer pockets shall be cleaned of debris between each flush. This shall be executed in sections utilizing blind flanges on sections of piping as applicable so that sufficient velocity can be applied to each section of piping flushed.
 - a. Air flush shall be performed a minimum of 3 times and repeated if the final flush produces dirt and debris in the strainer pockets
 - b. A target board may be used in lieu of a blind flange after the first air flush to determine if dirt or debris is being deposited at the end of the run being flushed.
 5. The final flush shall be with building steam.
 - a. Steam shall be slowly introduced to the system via warm-up and throttling valves to bring the pipes up to temperature. Condensate shall be drained from the system during warm-up via low point drains and drip-legs. Once the system is sufficiently warm flushing may begin.
 - b. Steam flushing shall occur in a similar manner to air flushing with a recommended flushing velocity of 12,000 FPM.
 - c. Strainers shall be removed and cleaned after each flush. Piping system shall be drained of condensate from low points and drip-legs after each flush.
 - d. Steam flushes shall be performed until dirt and debris is no longer observed in the strainers or discharge.
 - e. Clean Target boards also may be used to help determine if piping is clear of dirt and debris.
 6. Upon completion and acceptance of flushing by UM, the temporary piping and spool pieces shall be removed, and permanent system devices shall be reinstalled.
- C. Visual Examination (VT) of field welds are to be completed, paying particular attention to the root pass and cap. Radiographic Testing (RT) maybe employed by the owner in the event that questions about weld quality arise. If field welds are deemed to not meet the acceptance criteria in ASME B31.1, the contractor will replace the piping at no cost to the University.
- D. Testing Agency: Engage a qualified testing agency to perform tests and inspections.
- E. Manufacturer's Field Service: Engage a factory-authorized service representative to test and inspect components, assemblies, and equipment installations, including connections.
- F. Perform the following tests and inspections with compressed air:
1. Use ambient temperature water as a testing medium unless there is risk of damage due to freezing. Another liquid that is safe for workers and compatible with piping may be used.
 2. Subject piping system to hydrostatic test pressure that is not less than 1.5 times the working pressure. Test pressure shall not exceed maximum pressure for any vessel, pump, valve, or other component in system under test. Verify that stress due to pressure at bottom of vertical runs does not exceed 90 percent of specified minimum yield strength.
 3. After hydrostatic test pressure has been applied for at least 10 minutes, examine piping, joints, and connections for leakage. Eliminate leaks by tightening, repairing, or replacing components, and repeat hydrostatic test until there are no leaks.

- G. Prepare test and inspection reports.

END OF SECTION 232213

SECTION 232216 - STEAM AND CONDENSATE HEATING PIPING SPECIALTIES

PART 1 - GENERAL

1.1 RELATED DOCUMENTS

- A. Drawings and general provisions of the Contract, including General and Supplementary Conditions and Division 01 Specification Sections, apply to this Section.

1.2 SUMMARY

- A. Section includes the following piping specialties for steam and condensate piping:
 - 1. Strainers.
 - 2. Flash tanks.
 - 3. Stop-check valves.
 - 4. Safety valves.
 - 5. Pressure-reducing valves.
 - 6. Steam traps.
 - 7. Thermostatic air vents and vacuum breakers.
 - 8. Flexible connectors.
 - 9. Steam meters
 - 10. Condensate meters.
 - 11. Steam Filter
 - 12. Steam Separator
- B. Related Requirements:
 - 1. Section 230523 "General Duty Valves for HVAC Piping" for specification and installation requirements for globe valves common to most piping systems.

1.3 ACTION SUBMITTALS

- A. Product Data: For each type of product.
 - 1. Strainer.
 - 2. Flash tank.
 - 3. Valve.
 - 4. Steam trap.
 - 5. Air vent and vacuum breaker.
 - 6. Connector.
 - 7. Meter.

1.4 CLOSEOUT SUBMITTALS

- A. Operation and Maintenance Data: For valves, safety valves, pressure-reducing valves, steam traps, air vents, vacuum breakers, and meters to include in emergency, operation, and maintenance manuals.
- B. Provide steam trap schedule along with valve tag chart. Schedule should match approved submittals.

1.5 QUALITY ASSURANCE

- A. Pressure Vessel: Qualify procedures and operators according to the following:
 - 1. ASME Compliance: Safety valves and pressure vessels shall bear the appropriate ASME label. Fabricate and stamp flash tanks to comply with ASME Boiler and Pressure Vessel Code: Section VIII, Division 1.

PART 2 - PRODUCTS

2.1 PERFORMANCE REQUIREMENTS

- A. Components and installation shall be capable of withstanding the following minimum working pressures and temperatures unless otherwise indicated:
 - 1. HP Steam Piping: >100-psig
 - 2. LP Steam Piping: ≤100-psig
 - 3. Condensate Piping: 80 psig at 250 deg F.
 - 4. Makeup-Water Piping: 80 psig at 73 deg F.
 - 5. Blowdown-Drain Piping: Equal to pressure of the piping system to which it is attached.
 - 6. Air-Vent and Vacuum-Breaker Piping: Equal to pressure of the piping system to which it is attached.
 - 7. Safety-Valve-Inlet and -Outlet Piping: Equal to pressure of the piping system to which it is attached.

2.2 STRAINERS

- A. Y-Pattern Strainers:
 - 1. Body: ASTM A126, Class B cast iron, with bolted cover and bottom drain connection.
 - 2. End Connections: Threaded ends for strainers NPS 2 and smaller; flanged ends for strainers NPS 2-1/2 and larger.
 - 3. Strainer Screen: Stainless-steel, 40-mesh strainer or perforated stainless-steel basket.
 - 4. Tapped blowoff plug.
 - 5. CWP Rating: 250-psig working steam pressure.
- B. Basket Strainers:

1. Body: ASTM A126, Class B cast iron, with bolted cover and bottom drain connection.
2. End Connections: Threaded ends for strainers NPS 2 and smaller; flanged ends for strainers NPS 2-1/2 and larger.
3. Strainer Screen: Stainless-steel, 20 mesh strainer and perforated stainless-steel basket with 50 percent free area.
4. CWP Rating: 250-psig working steam pressure.

2.3 FLASH TANKS

- A. Factory fabricated of welded steel according to ASME Boiler and Pressure Vessel Code for 150-psig rating, and bearing ASME label. Fabricate with tappings for low-pressure steam and condensate outlets, high-pressure condensate inlet, air vent, safety valve, and legs.
 1. Manufactures:
 - a. Armstrong International
 - b. Dunham-Bush Inc.
 - c. Hoffman Specialty
 - d. The Johnson Corporation
 - e. Spirax Sarco Limited
 - f. Tunstall Corporation
 - g. TLV Corporation

2.4 STOP-CHECK VALVES

- A. Stop-Check Valves:
 1. Manufactures:
 - a. Armstrong International
 - b. Dunham-Bush Inc.
 - c. Hoffman Specialty
 - d. The Johnson Corporation
 - e. Spirax Sarco Limited
 - f. Tunstall Corporation
 - g. TLV Corporation
 2. Body and Bonnet: Malleable iron.
 3. End Connections: Flanged.
 4. Disc: Cylindrical with removable liner and machined seat.
 5. Stem: Brass alloy.
 6. Operator: Outside screw and yoke with cast-iron handwheel.
 7. Packing: PTFE-impregnated packing with two-piece packing gland assembly.
 8. Pressure Class: 250.

2.5 STEAM SAFETY VALVES

- A. Cast-Iron Steam Safety Valves: ASME labeled.
 1. Manufactures:
 - a. Armstrong International
 - b. Dunham-Bush Inc.
 - c. Hoffman Specialty

- d. The Johnson Corporation
- e. Spirax Sarco Limited
- f. Tunstall Corporation
- g. TLV Corporation
2. Disc Material: Forged copper alloy with bronze nozzle.
3. End Connections: Raised-face flanged inlet and threaded or flanged outlet connections.
4. Spring: Fully enclosed cadmium-plated steel spring with adjustable pressure range and positive shutoff, factory set and sealed.
5. Pressure Class: 250.
6. Drip-Pan Elbow: Cast iron and having threaded inlet, outlet, and drain, with threads complying with ASME B1.20.1.
7. Exhaust Head: Cast iron and having threaded inlet and drain, with threads complying with ASME B1.20.1.
8. Size and Capacity: As required for equipment according to ASME Boiler and Pressure Vessel Code.

2.6 PRESSURE-REDUCING VALVES

1. Manufactures:
 - a. Armstrong International
 - b. Dunham-Bush Inc.
 - c. Hoffman Specialty
 - d. The Johnson Corporation
 - e. Spirax Sarco Limited
 - f. Tunstall Corporation
 - g. TLV Corporation
- B. ASME labeled.
- C. Size, Capacity, and Pressure Rating: Factory set for inlet and outlet pressures indicated.
- D. Description: Pilot-actuated diaphragm type, with adjustable pressure range and positive shutoff.
- E. Body: Cast iron.
- F. End Connections: Threaded connections for valves NPS 2 and smaller and flanged connections for valves NPS 2-1/2 and larger.
- G. Trim: Hardened stainless steel.
- H. Head and Seat: Replaceable, main head stem guide fitted with flushing and pressure-arresting device cover over pilot diaphragm.
- I. Gaskets: Gaskets shall be manufactured of Graphite Spiral Wound Metal equal to Flextallic. Materials must be Non-asbestos.

2.7 STEAM TRAPS

- A. Thermostatic Steam Traps:

1. Manufactures:
 - a. Armstrong International
 - b. Dunham-Bush Inc.
 - c. Hoffman Specialty
 - d. The Johnson Corporation
 - e. Spirax Sarco Limited
 - f. Tunstall Corporation
 - g. TLV Corporation
 2. Body: Bronze angle-pattern body with integral union tailpiece and screw-in cap.
 3. Trap Type: Balanced pressure.
 4. Bellows: Stainless steel or monel.
 5. Head and Seat: Replaceable, hardened stainless steel.
 6. Pressure Class: 125.
- B. Thermodynamic Steam Traps:
1. Manufactures:
 - a. Armstrong International
 - b. Dunham-Bush Inc.
 - c. Hoffman Specialty
 - d. The Johnson Corporation
 - e. Spirax Sarco Limited
 - f. Tunstall Corporation
 - g. TLV Corporation
 2. Body: Stainless steel with screw-in cap.
 3. End Connections: Threaded.
 4. Disc and Seat: Stainless steel.
 5. Maximum Operating Pressure: 600 psig.
- C. Float and Thermostatic Steam Traps:
1. Manufactures:
 - a. Armstrong International
 - b. Dunham-Bush Inc.
 - c. Hoffman Specialty
 - d. The Johnson Corporation
 - e. Spirax Sarco Limited
 - f. Tunstall Corporation
 - g. TLV Corporation
 2. Body and Bolted Cap: ASTM A126 cast iron.
 3. End Connections: Threaded.
 4. Float Mechanism: Replaceable, stainless steel.
 5. Head and Seat: Hardened stainless steel.
 6. Trap Type: Balanced pressure.
 7. Thermostatic Bellows: Stainless steel or monel.
 8. Thermostatic air vent capable of withstanding 45 deg F of superheat and resisting water hammer without sustaining damage.
 9. Vacuum Breaker: Thermostatic with phosphor bronze bellows, and stainless-steel cage, valve, and seat.
 10. Maximum Operating Pressure: 125 psig.
- D. Inverted Bucket Steam Traps:

1. Manufactures:
 - a. Armstrong International
 - b. Dunham-Bush Inc.
 - c. Hoffman Specialty
 - d. The Johnson Corporation
 - e. Spirax Sarco Limited
 - f. Tunstall Corporation
 - g. TLV Corporation
2. Body and Cap: Cast iron.
3. End Connections: Threaded.
4. Head and Seat: Stainless steel.
5. Valve Retainer, Lever, and Guide Pin Assembly: Stainless steel.
6. Bucket: Brass or stainless steel.
7. Strainer: Integral stainless-steel inlet strainer within the trap body.
8. Air Vent: Stainless-steel thermostatic vent.
9. Pressure Rating: 250 psig.

2.8 THERMOSTATIC AIR VENTS AND VACUUM BREAKERS

A. Thermostatic Air Vents:

1. Manufactures:
 - a. Armstrong International
 - b. Dunham-Bush Inc.
 - c. Hoffman Specialty
 - d. The Johnson Corporation
 - e. Spirax Sarco Limited
 - f. Tunstall Corporation
 - g. TLV Corporation
2. Body: Cast iron, bronze, or stainless steel.
3. End Connections: Threaded.
4. Float, Valve, and Seat: Stainless steel.
5. Thermostatic Element: Phosphor bronze bellows in a stainless-steel cage.
6. Pressure Rating: 125 psig.
7. Maximum Temperature Rating: 350 deg F

B. Vacuum Breakers:

1. Manufactures:
 - a. Armstrong International
 - b. Dunham-Bush Inc.
 - c. Hoffman Specialty
 - d. The Johnson Corporation
 - e. Spirax Sarco Limited
 - f. Tunstall Corporation
 - g. TLV Corporation
2. Body: Cast iron, bronze, or stainless steel.
3. End Connections: Threaded.
4. Sealing Ball, Retainer, Spring, and Screen: Stainless steel.
5. O-Ring Seal: Ethylene propylene rubber.
6. Pressure Rating: 125 psig.

7. Maximum Temperature Rating: 350 deg F

2.9 FLEXIBLE CONNECTORS

A. Stainless-Steel Bellows, Flexible Connectors:

1. Manufactures:
 - a. Armstrong International
 - b. Dunham-Bush Inc.
 - c. Hoffman Specialty
 - d. The Johnson Corporation
 - e. Spirax Sarco Limited
 - f. Tunstall Corporation
 - g. TLV Corporation
2. Body: Stainless-steel bellows with woven, flexible, bronze, wire-reinforced, protective jacket.
3. End Connections: Threaded or flanged to match equipment connected.
4. Performance: Capable of 3/4-inch misalignment.
5. CWP Rating: 150 psig.
6. Maximum Operating Temperature: 250 deg F.

2.10 STEAM METERS

- A. Refer to 230923.13

2.11 CONDENSATE METERS

- A. Refer to 230923.13

2.12 STEAM CONDENSATE TEMPERING DEVICE

A. Carbon Steel Body, Malleable Iron Fittings; Bronze Sensing Bulb:

1. Manufactures:
 - a. Armstrong International
 - b. Dunham-Bush Inc.
 - c. Hoffman Specialty
 - d. The Johnson Corporation
 - e. Parker
 - f. Spirax Sarco Limited
 - g. Tunstall Corporation
 - h. TLV Corporation
2. End Connections: Threaded or flange to match equipment connected.
3. Performance: Factory preset with 135F discharge.
4. Max operating pressure (psig): 150 psig.
5. Port Size – per selection based on Condensate Load

- B. Description: Unit pre-assembled package that is suitable for any plumbing system. When hot condensate or hot water is drained into the condensate cooler body, the tempering valve opens and allows cold water to enter the chamber and mix with hotter liquid, cooling it to a preset temperature level of 135°F (57°C) or to a desired field set temperature.

2.13 STEAM FILTER

- A. Stainless-Steel housing with filter cartridge:
 - 1. Manufactures:
 - a. Armstrong International
 - b. Dunham-Bush Inc.
 - c. Hoffman Specialty
 - d. The Johnson Corporation
 - e. Parker
 - f. Spirax Sarco Limited
 - g. Tunstall Corporation
 - h. TLV Corporation
 - 2. Body: 304 Stainless-steel; EPR Seals.
 - 3. End Connections: Threaded or flange to match equipment connected.
 - 4. Performance: 98% removal at 1 micron.
 - 5. Max operating pressure (psig): 80 psig.
 - 6. Port Size 1”
 - 7. Maximum Operating Temperature: 250 deg F.

2.14 STEAM SEPARATOR

- A. Baffle Type Designed to Section VIII, Division 1 of Boiler & pressure code:
 - 1. Manufactures:
 - a. Armstrong International
 - b. Dunham-Bush Inc.
 - c. Hoffman Specialty
 - d. The Johnson Corporation
 - e. Spirax Sarco Limited
 - f. Tunstall Corporation
 - g. TLV Corporation
 - 2. Description: Separator shall be of the high efficiency internal baffle type having a pressure drop that does not exceed an equivalent length of pipe. Separator shall be of steel construction in accordance with Section VIII, Division I of the ASME Boiler and Pressure Vessel Code. ASME Code Stamped for maximum working pressures of 150, 300, or 600 psig. A screwed bottom drain connection shall be provided for the installation of a trap to discharge accumulated liquid.
 - 3. Performance: Steam Dryness Greater than 95%.

2.15 STEAM SURPLUSSING VALVE

- A. Self Actuated Back Pressure Control Valve with Piston Design:
 - 1. Manufactures:

- a. Armstrong International
- b. Dunham-Bush Inc.
- c. Hoffman Specialty
- d. The Johnson Corporation
- e. Spirax Sarco Limited
- f. Tunstall Corporation
- g. TLV Corporation
2. Body: Carbon Iron (FC250).
3. End Connections: Flanged to match equipment connected with PTFE Gaskets.
4. Performance: Refer to Schedule
5. CWP Rating: 150 psig.
6. Maximum Operating Temperature: 250 deg F.
7. Pressure Setting Range: 15 – 150 PSI

PART 3 - EXECUTION

3.1 INSULATION

- A. Apply insulation per sections 230700 to piping and components. Insulation to be applied to all steam specialties as surfaces permit as not to interfere with moving parts. Insulation should be applied to all components indicated in section 1.2 where installed.

3.2 STEAM TRAP APPLICATIONS

- A. Install traps based on size and capacity as indicated on mechanical drawings.
- B. Inverted bucket traps are not to be installed outside of mechanical rooms – where inverted bucket traps are indicated at building equipment provide and install a Float & Thermostatic type.

3.3 VALVE APPLICATIONS

- A. Install shutoff duty valves at branch connections to steam supply mains, at steam supply connections to equipment, and at the outlet of steam traps.
- B. Install safety valves on pressure-reducing stations and elsewhere as required by ASME Boiler and Pressure Vessel Code. Install safety-valve discharge piping, without valves, to nearest floor drain or as indicated on Drawings. Comply with ASME Boiler and Pressure Vessel Code: Section VIII, Division 1, for installation requirements.

3.4 PIPING INSTALLATION

- A. Install piping to permit valve servicing.

- B. Install drains, consisting of a tee fitting, NPS 3/4 full-port ball valve, and short NPS 3/4 threaded nipple with cap, at low points in piping system mains and elsewhere as required for system drainage.
- C. Install valves according to Section 230523.11 "Globe Valves for HVAC Piping," Section 230523.12 "Ball Valves for HVAC Piping," Section 230523.13 "Butterfly Valves for HVAC Piping," Section 230523.14 "Check Valves for HVAC Piping," and Section 230523.15 "Gate Valves for HVAC Piping."
- D. Install unions in piping, NPS 2 and smaller, adjacent to valves, at final connections of equipment and elsewhere as indicated.
- E. Install flanges in piping, NPS 2-1/2 and larger, at final connections of equipment and elsewhere as indicated.
- F. Install shutoff valve immediately upstream of each dielectric fitting.
- G. Install strainers on a horizontal plane; install strainers on supply side of control valves, pressure-reducing valves, traps, and elsewhere as indicated. Install NPS 3/4 nipple and full-port ball valve in blowdown connection of strainers NPS 2 and larger. Match size of strainer blowoff connection for strainers smaller than NPS 2.
- H. Flash Tank:
 - 1. Pitch condensate piping down toward flash tank.
 - 2. If more than one condensate pipe discharges into flash tank, install a check valve in each line.
 - 3. Install thermostatic air vent at tank top.
 - 4. Install safety valve at tank top.
 - 5. Install full-port ball valve, and swing check valve on condensate outlet.
 - 6. Install inverted bucket or float and thermostatic trap at low-pressure condensate outlet, sized for 3 times the calculated heat load.
 - 7. Install pressure gage on low-pressure steam outlet according to Section 230519 "Meters and Gages for HVAC Piping."

3.5 STEAM-TRAP INSTALLATION

- A. Install steam traps in accessible locations as close as possible to connected equipment.
- B. Install full-port ball valve, strainer, and union upstream from trap; install union, check valve, and full-port ball valve downstream from trap unless otherwise indicated.
- C. Tag each steam trap installed and provide steam trap schedule matching the tagging scheme. Refer to close out submittals.

3.6 PRESSURE-REDUCING VALVE INSTALLATION

- A. Install pressure-reducing valves in accessible location for maintenance and inspection – pilot for PRV should be rotated to facilitate service.
- B. Install bypass piping around pressure-reducing valves, with globe valve equal in size to area of pressure-reducing valve seat ring, unless otherwise indicated.
- C. Install gate valves on both sides of pressure-reducing valves.
- D. Install unions or flanges on both sides of pressure-reducing valves having threaded- or flanged-end connections, respectively.
- E. Install pressure gages on low-pressure side of pressure-reducing valves after the bypass connection according to Section 230519 "Meters and Gages for HVAC Piping."
- F. Install strainers upstream for pressure-reducing valve.
- G. Install safety valve downstream from pressure-reducing valve station.

3.7 STEAM OR CONDENSATE METER INSTALLATION

- A. Install meters with lengths of straight pipe upstream and downstream according to steam meter manufacturer's written instructions.
- B. Provide data acquisition wiring. See Section 230923 "Direct Digital Control (DDC) System for HVAC"

3.8 SAFETY VALVE INSTALLATION

- A. Install safety valves according to ASME B31.9, "Building Services Piping."
- B. Pipe safety-valve discharge without valves to atmosphere outside the building.
- C. Install drip-pan elbow fitting adjacent to safety valve and pipe drain connection to nearest floor drain.
- D. Install exhaust head with drain to waste, on vents equal to or larger than NPS 2-1/2.

3.9 TERMINAL EQUIPMENT CONNECTIONS

- A. Install traps and control valves in accessible locations close to connected equipment.
- B. Install bypass piping with globe valve around control valve. If parallel control valves are installed, only one bypass is required.
- C. Install vacuum breakers downstream from control valve, close to coil inlet connection.

END OF SECTION 232216

SECTION 232223 - STEAM CONDENSATE PUMPS

PART 1 - GENERAL

1.1 RELATED DOCUMENTS

- A. Drawings and general provisions of the Contract, including General and Supplementary Conditions and Division 01 Specification Sections, apply to this Section.

1.2 SUMMARY

- A. Section includes steam condensate pumps.

1.3 ACTION SUBMITTALS

- A. Product Data: For each type of product. Include certified performance curves and rated capacities, operating characteristics, furnished specialties, and accessories for each type of product indicated. Indicate pump's operating point on curves. Include receiver capacity and material.
- B. Shop Drawings: For each pump.
 - 1. Show pump layout and connections.
 - 2. Include setting drawings with templates for installing foundation and anchor bolts and other anchorages.
 - 3. Include diagrams for power, signal, and control wiring.

1.4 CLOSEOUT SUBMITTALS

- A. Operation and Maintenance Data: For pumps to include in emergency, operation, and maintenance manuals.

PART 2 - PRODUCTS

1. SINGLE-STAGE, CENTRIFUGAL PUMPS WITH FLOOR-MOUNTED RECEIVER

- A. Manufactures:
 - 1. Armstrong Fluid Handling
 - 2. Bell & Gossett
 - 3. ITT Corporation
 - 4. Skidmore Pump
 - 5. Spirax Sarco Limited
 - 6. Shipco Pumps

- B. Description: Factory-fabricated, packaged, electric-driven pumps; with receiver, pumps, controls, and accessories suitable for operation with steam condensate – Refer to schedules for capacities and receiver sizes.
1. Electrical Components, Devices, and Accessories: Listed and labeled as defined in NFPA 70, by a qualified testing agency, and marked for intended location and application.
 2. ASME Compliance: Fabricate and label steam condensate receivers to comply with ASME Boiler and Pressure Vessel Code: Section VIII, Division 1.
- C. Configuration: Duplex floor-mounted pump with receiver and float switches; rated to pump 250 deg F steam condensate –
1. Provide pressure independent adjustable balancing valve at pump discharge.
- D. Receiver:
1. Floor mounted.
 2. Close-grained cast iron or Welded steel.
 3. Externally adjustable float switches.
 4. Flanges for pump mounting.
 5. Water-level gage and dial thermometer.
 6. Pressure gage at pump discharge.
 7. Bronze fitting isolation valve between pump and receiver.
 8. Lifting eyebolts.
 9. Inlet vent and an overflow.
 10. Low point drain with integral isolation valve.
 11. Cast-iron inlet strainer with vertical self-cleaning bronze screen and large dirt pocket.
- E. Pumps:
1. Centrifugal, close coupled, vertical design.
 2. Permanently aligned.
 3. Bronze fitted.
 4. Replaceable bronze case ring.
 5. Mechanical seals rated at 250 deg F.
 6. Mounted on receiver flange.
- F. Motor:
1. Comply with NEMA designation, temperature rating, service factor, and efficiency requirements for motors specified in Section 230513 "Common Motor Requirements for HVAC Equipment."
 2. Enclosure: Open, dripproof.
 3. Enclosure Materials: Cast aluminum or Rolled steel.
 4. Motor Bearings: Permanently lubricated ball bearings.
 5. Unusual Service Conditions:
 - a. Ambient Temperature: 85F.
 - b. Altitude: 70 feet above sea level.
 - c. High humidity.

6. Efficiency: Premium efficient.
7. NEMA Design: Type 3.
8. Service Factor: 1.5.

G. Control Panel:

1. Factory wired between pumps and float switches, for single external electrical connection.
2. Provide 24v DC Fused primary & Secondary Transformers, Control Circuit Disconnect Switch with Shield wiring of 24 volt circuits.
3. Manual Override of unit from Building Automation System.
4. NEMA 250, Type 3 enclosure with hinged door and grounding lug, mounted on pump.
5. Motor controller for each pump.
6. Provide continuous water level monitoring and adjustment.
7. Electrical pump alternator to operate pumps in lead-lag sequence and allow both pumps to operate on receiver high level.
8. Manual lead-lag control to override electrical pump alternator and manually select the lead pump.
9. Green Run Light, Red Fault light, Grey inactive light (all per pump)
10. Momentary-contact "TEST" push button on cover for each pump.
11. Numbered terminal strip.
12. High water temperature alarm
13. High Water Temperature Cutoff / Shutoff to protect pump from cavitation.
14. Alarm ledger which logs irregular operating conditions (warnings and alarms).
15. Disconnect switch. If Project has more than one type or configuration of small floor-mounted pump with receiver and float switches, delete "Capacities and Characteristics" Paragraph below and schedule pumps on Drawings.

PART 3 - EXECUTION

3.1 EXAMINATION

- A. Examine equipment foundations and anchor-bolt locations for compliance with requirements for installation tolerances and other conditions affecting performance of the Work.
- B. Examine roughing-in for piping systems to verify actual locations of piping connections before pump installation.
- C. Proceed with installation only after unsatisfactory conditions have been corrected.

3.2 INSTALLATION

- A. Install pumps according to HI 1.1-1.2, HI 1.3, and HI 1.4.
- B. Install pumps to provide access for periodic maintenance including removing motors, impellers, couplings, and accessories.

- C. Support pumps and piping separately so piping is not supported by pumps.
- D. Install thermometers and pressure gages.
- E. Equipment Mounting:
 - 1. Install pumps on cast-in-place concrete equipment base(s). Comply with requirements for equipment bases and foundations specified in Section 033000 "Cast-in-Place Concrete."
 - 2. Comply with requirements for vibration isolation and seismic control devices specified in Section 230548 "Vibration and Seismic Controls for HVAC."
 - 3. Comply with requirements for vibration isolation devices specified in Section 230548.13 "Vibration Controls for HVAC."

3.3 CONNECTIONS

- A. Comply with requirements for piping specified in Section 232213 "Steam and Condensate Heating Piping" and Section 232216 "Steam and Condensate Heating Piping Specialties."
- B. Where installing piping adjacent to machine, allow space for service and maintenance.
- C. The control panel must be mounted in an accessible location with minimum 3 feet clearance in front of panel – if tank is located in a pit mount control panel remotely in the main mechanical room.
- D. Install compressed-air supply for pressure-powered pumps as required in Section 221513 "General-Service Compressed-Air Piping."
- E. Install a globe and check valve and pressure gage before inlet of each pump and a gate and check valve at pump outlet.
- F. Pipe drain to nearest floor drain for overflow and drain piping connections.
- G. Install full-size vent piping to outdoors, terminating in 180-degree elbow at point above highest steam system connection or as indicated.
- H. Ground equipment according to Section 260526 "Grounding and Bonding for Electrical Systems."
- I. Connect wiring according to Section 260519 "Low-Voltage Electrical Power Conductors and Cables."

3.4 STARTUP SERVICE

- A. Engage a factory-authorized service representative to perform startup service.
 - 1. Complete installation and startup checks according to manufacturer's written instructions.
 - 2. Clean strainers.
 - 3. Set steam condensate pump controls.

4. Set pump controls for automatic start, stop, and alarm operation.
5. Perform the following preventive maintenance operations and checks before starting:
 - a. Set float switches to operate at proper levels.
 - b. Set throttling valves on pump discharge for specified flow.
 - c. Check motors for proper rotation.
 - d. Test pump controls and demonstrate compliance with requirements.
 - e. Replace damaged or malfunctioning pump controls and equipment.
 - f. Verify that pump controls are correct for required application.
6. Start steam condensate pumps according to manufacturer's written startup instructions.

3.5 DEMONSTRATION

- A. Engage a factory-authorized service representative to train Owner's maintenance personnel to adjust, operate, and maintain steam condensate pumps.

END OF SECTION 232223

SECTION 232300 - REFRIGERANT PIPING

PART 1 - GENERAL

1.1 RELATED DOCUMENTS

- A. Drawings and general provisions of the Contract, including General and Supplementary Conditions and Division 01 Specification Sections, apply to this Section.

1.2 SUMMARY

- A. This Section includes refrigerant piping used for air-conditioning applications.

1.3 PERFORMANCE REQUIREMENTS

- A. Line Test Pressure for Refrigerant R-134a:
 - 1. Suction Lines for Air-Conditioning Applications: 225 psig.
 - 2. Suction Lines for Heat-Pump Applications: 225 psig.
 - 3. Hot-Gas and Liquid Lines: 225 psig.
- B. Line Test Pressure for Refrigerant R-407C:
 - 1. Suction Lines for Air-Conditioning Applications: 380 psig.
 - 2. Suction Lines for Heat-Pump Applications: 380 psig.
 - 3. Hot-Gas and Liquid Lines: 380 psig.
- C. Line Test Pressure for Refrigerant R-410A:
 - 1. Suction Lines for Air-Conditioning Applications: 535 psig.
 - 2. Suction Lines for Heat-Pump Applications: 535 psig.
 - 3. Hot-Gas and Liquid Lines: 535 psig.

1.4 SUBMITTALS

- A. Product Data: For each type of valve and refrigerant piping specialty indicated. Include pressure drop, based on manufacturer's test data, for the following:
 - 1. Thermostatic expansion valves.
 - 2. Solenoid valves.
 - 3. Hot-gas bypass valves.
 - 4. Filter dryers.
 - 5. Strainers.
 - 6. Pressure-regulating valves.

- B. Shop Drawings: Show layout of refrigerant piping and specialties, including pipe, tube, and fitting sizes, flow capacities, valve arrangements and locations, slopes of horizontal runs, oil traps, double risers, wall and floor penetrations, and equipment connection details. Show interface and spatial relationships between piping and equipment.
 - 1. Shop Drawing Scale: 1/4 inch equals 1 foot.
 - 2. Refrigerant piping indicated on Drawings is schematic only. Size piping and design actual piping layout, including oil traps, double risers, specialties, and pipe and tube sizes to accommodate, as a minimum, equipment provided, elevation difference between compressor and evaporator, and length of piping to ensure proper operation and compliance with warranties of connected equipment.
 - 3. Suction line velocities sized for 1000 fpm velocity minimum. Minimum Trapping: 1 trap at evap/1 trap inverted at top of riser when conds unit above evap. Alternate trap suction risers at 15' vertical intervals.
- C. Welding certificates. Refrigerant piping shall be installed by technicians certified in accordance with Section 608 of the 1990 Clean Air Act.
- D. Field quality-control test reports.
- E. Operation and Maintenance Data: For refrigerant valves and piping specialties to include in maintenance manuals.

1.5 QUALITY ASSURANCE

- A. Welding: Qualify procedures and personnel according to ASME Boiler and Pressure Vessel Code: Section IX, "Welding and Brazing Qualifications."
- B. Comply with ASHRAE 15, "Safety Code for Refrigeration Systems."
- C. Comply with ASME B31.5, "Refrigeration Piping and Heat Transfer Components."

1.6 PRODUCT STORAGE AND HANDLING

- A. Store piping in a clean and protected area with end caps in place to ensure that piping interior and exterior are clean when installed.

1.7 COORDINATION

- A. Coordinate size and location of roof curbs, equipment supports, and roof penetrations. These items are specified in Division 07 Section "Roof Accessories."

PART 2 - PRODUCTS

2.1 COPPER TUBE AND FITTINGS

- A. Copper Tube: ASTM B 88, Type K or L (ASTM B 88M, Type A or B) or ASTM B 280, Type ACR.
- B. Wrought-Copper Fittings: ASME B16.22.
- C. Wrought-Copper Unions: ASME B16.22.
- D. Brazing Filler Metals: AWS A5.8.
- E. Flexible Connectors:
 - 1. Body: Tin-bronze bellows with woven, flexible, tinned-bronze-wire-reinforced protective jacket.
 - 2. End Connections: Socket ends.
 - 3. Offset Performance: Capable of minimum 3/4-inch misalignment in minimum 7-inch- (180-mm-) long assembly.
 - 4. Pressure Rating: Factory test at minimum 500 psig.
 - 5. Maximum Operating Temperature: 250 deg F.

2.2 VALVES AND SPECIALTIES

- A. Diaphragm Packless Valves:
 - 1. Body and Bonnet: Forged brass or cast bronze; globe design with straight-through or angle pattern.
 - 2. Diaphragm: Phosphor bronze and stainless steel with stainless-steel spring.
 - 3. Operator: Rising stem and hand wheel.
 - 4. Seat: Nylon.
 - 5. End Connections: Socket or union.
 - 6. Working Pressure Rating: 500 psig.
 - 7. Maximum Operating Temperature: 275 deg F.
- B. Check Valves:
 - 1. Body: Ductile iron, forged brass, or cast bronze; globe pattern.
 - 2. Bonnet: Bolted ductile iron, forged brass, or cast bronze; or brass hex plug.
 - 3. Piston: Removable polytetrafluoroethylene seat.
 - 4. Closing Spring: Stainless steel.
 - 5. Manual Opening Stem: Seal cap, plated-steel stem, and graphite seal.
 - 6. End Connections: Socket, union or threaded.
 - 7. Maximum Opening Pressure: 0.50 psig.
 - 8. Working Pressure Rating: 500 psig.
 - 9. Maximum Operating Temperature: 275 deg F.

- C. Service Valves:
1. Body: Forged brass with brass cap including key end to remove core.
 2. Core: Removable ball-type check valve with stainless-steel spring.
 3. Seat: Polytetrafluoroethylene.
 4. End Connections: Copper spring.
 5. Working Pressure Rating: 500 psig.
- D. Solenoid Valves: Comply with ARI 760 and UL 429; listed and labeled by an NRTL.
1. Body and Bonnet: Plated steel.
 2. Solenoid Tube, Plunger, Closing Spring, and Seat Orifice: Stainless steel.
 3. Seat: Polytetrafluoroethylene.
 4. End Connections: Threaded.
 5. Electrical: Molded, watertight coil in NEMA 250 enclosure of type required by location with 1/2-inch conduit adapter, and 24-V ac coil.
 6. Working Pressure Rating: 400 psig.
 7. Maximum Operating Temperature: 240 deg F.
 8. Manual operator.
- E. Safety Relief Valves: Comply with ASME Boiler and Pressure Vessel Code; listed and labeled by an NRTL.
1. Body and Bonnet: Ductile iron and steel, with neoprene O-ring seal.
 2. Piston, Closing Spring, and Seat Insert: Stainless steel.
 3. Seat Disc: Polytetrafluoroethylene.
 4. End Connections: Threaded.
 5. Working Pressure Rating: 400 psig.
 6. Maximum Operating Temperature: 240 deg F.
- F. Thermostatic Expansion Valves: Comply with ARI 750.
1. Body, Bonnet, and Seal Cap: Forged brass or steel.
 2. Diaphragm, Piston, Closing Spring, and Seat Insert: Stainless steel.
 3. Packing and Gaskets: Non-asbestos.
 4. Capillary and Bulb: Copper tubing filled with refrigerant charge.
 5. Suction Temperature: 40 deg F.
 6. Superheat: Adjustable.
 7. Reverse-flow option (for heat-pump applications).
 8. End Connections: Socket, flare, or threaded union.
 9. Working Pressure Rating: 700 psig.
- G. Hot-Gas Bypass Valves: Comply with UL 429; listed and labeled by an NRTL.
1. Body, Bonnet, and Seal Cap: Ductile iron or steel.
 2. Diaphragm, Piston, Closing Spring, and Seat Insert: Stainless steel.
 3. Packing and Gaskets: Non-asbestos.
 4. Solenoid Tube, Plunger, Closing Spring, and Seat Orifice: Stainless steel.
 5. Seat: Polytetrafluoroethylene.
 6. Equalizer: External.

7. Electrical: Molded, watertight coil in NEMA 250 enclosure of type required by location with 1/2-inch conduit adapter, and 24-V ac coil.
8. End Connections: Socket.
9. Throttling Range: Maximum 5 psig.
10. Working Pressure Rating: 500 psig.
11. Maximum Operating Temperature: 240 deg F.

H. Straight-Type Strainers:

1. Body: Welded steel with corrosion-resistant coating.
2. Screen: 100-mesh stainless steel.
3. End Connections: Socket or flare.
4. Working Pressure Rating: 500 psig.
5. Maximum Operating Temperature: 275 deg F.

I. Angle-Type Strainers:

1. Body: Forged brass or cast bronze.
2. Drain Plug: Brass hex plug.
3. Screen: 100-mesh monel.
4. End Connections: Socket or flare.
5. Working Pressure Rating: 500 psig.
6. Maximum Operating Temperature: 275 deg F.

J. Moisture/Liquid Indicators:

1. Body: Forged brass.
2. Window: Replaceable, clear, fused glass window with indicating element protected by filter screen.
3. Indicator: Color coded to show moisture content in ppm.
4. Minimum Moisture Indicator Sensitivity: Indicate moisture above 60 ppm.
5. End Connections: Socket or flare.
6. Working Pressure Rating: 500 psig.
7. Maximum Operating Temperature: 240 deg F.

K. Replaceable-Core Filter Dryers: Comply with ARI 730.

1. Body and Cover: Painted-steel shell with ductile-iron cover, stainless-steel screws, and neoprene gaskets.
2. Filter Media: 10 micron, pleated with integral end rings; stainless-steel support.
3. Desiccant Media: Activated alumina.
4. Designed for reverse flow (for heat-pump applications).
5. End Connections: Socket.
6. Access Ports: NPS 1/4 connections at entering and leaving sides for pressure differential measurement.
7. Maximum Pressure Loss: 2 psig.
8. Working Pressure Rating: 500 psig.
9. Maximum Operating Temperature: 240 deg F.

L. Permanent Filter Dryers: Comply with ARI 730.

1. Body and Cover: Painted-steel shell.
2. Filter Media: 10 micron, pleated with integral end rings; stainless-steel support.
3. Desiccant Media: Activated charcoal.
4. Designed for reverse flow (for heat-pump applications).
5. End Connections: Socket.
6. Access Ports: NPS 1/4 connections at entering and leaving sides for pressure differential measurement.
7. Maximum Pressure Loss: 2 psig.
8. Working Pressure Rating: 525 psig.
9. Maximum Operating Temperature: 240 deg F.

M. Mufflers:

1. Body: Welded steel with corrosion-resistant coating.
2. End Connections: Socket or flare.
3. Working Pressure Rating: 500 psig.
4. Maximum Operating Temperature: 275 deg F.

N. Receivers: Comply with ARI 495.

1. Comply with ASME Boiler and Pressure Vessel Code; listed and labeled by an NRTL.
2. Comply with UL 207; listed and labeled by an NRTL.
3. Body: Welded steel with corrosion-resistant coating.
4. Tappings: Inlet, outlet, liquid level indicator, and safety relief valve.
5. End Connections: Socket or threaded.
6. Working Pressure Rating: 525 psig.
7. Maximum Operating Temperature: 275 deg F.

O. Liquid Accumulators: Comply with ARI 495.

1. Body: Welded steel with corrosion-resistant coating.
2. End Connections: Socket or threaded.
3. Working Pressure Rating: 525 psig.
4. Maximum Operating Temperature: 275 deg F.

2.3 REFRIGERANTS

A. Available Manufacturers: Subject to compliance with requirements, manufacturers offering products that may be incorporated into the Work include, but are not limited to, the following:

B. Manufacturers: Subject to compliance with requirements, provide products by one of the following:

1. Atofina Chemicals, Inc.
2. DuPont Company; Fluorochemicals Div.
3. Honeywell, Inc.; Genetron Refrigerants.
4. INEOS Fluor Americas LLC.

C. ASHRAE 34, R-134a: Tetrafluoroethane.

- D. ASHRAE 34, R-407C: Difluoromethane/Pentafluoroethane/1,1,1,2-Tetrafluoroethane.
- E. ASHRAE 34, R-410A: Pentafluoroethane/Difluoromethane.

PART 3 - EXECUTION

3.1 PIPING APPLICATIONS

- A. Suction Lines NPS 1-1/2 and Smaller for Conventional Air-Conditioning Applications: Copper, Type ACR, annealed-temper tubing and wrought-copper fittings with brazed joints.
- B. Suction Lines NPS 2 to NPS 4 for Conventional Air-Conditioning Applications: Copper, Type ACR, drawn-temper tubing and wrought-copper fittings with brazed joints.
- C. Hot-Gas and Liquid Lines, and Suction Lines for Heat-Pump Applications: Copper, Type ACR, annealed-temper tubing and wrought-copper fittings with brazed joints.
- D. Safety-Relief-Valve Discharge Piping: Copper, Type K (A), drawn-temper tubing and wrought-copper fittings with brazed joints.
- E. Safety-Relief-Valve Discharge Piping: Copper, Type ACR, drawn-temper tubing and wrought-copper fittings with brazed joints.
- F. Safety-Relief-Valve Discharge Piping:
 - 1. Comply with ASHRAE Standard 15-2007 for installation practices.
 - 2. NPS 1-1/2 and Smaller: Copper, Type L (B), drawn-temper tubing and wrought-copper fittings with brazed joints.
 - 3. NPS 2 to NPS 3: Copper, Type K (A), annealed- or drawn-temper tubing and wrought-copper fittings with brazed joints.
 - 4. NPS 4: Copper, Type K (A), drawn-temper tubing and wrought-copper fittings with brazed joints.

3.2 VALVE AND SPECIALTY APPLICATIONS

- A. Install diaphragm packless valves in suction and discharge lines of compressor.
- B. Install service valves for gage taps at inlet and outlet of hot-gas bypass valves and strainers if they are not an integral part of valves and strainers.
- C. Install a check valve at the compressor discharge and a liquid accumulator at the compressor suction connection.
- D. Except as otherwise indicated, install diaphragm packless valves on inlet and outlet side of filter dryers.
- E. Install a full-sized, three-valve bypass around filter dryers.

- F. Install solenoid valves upstream from each expansion valve and hot-gas bypass valve. Install solenoid valves in horizontal lines with coil at top.
- G. Install thermostatic expansion valves as close as possible to distributors on evaporators.
 - 1. Install valve so diaphragm case is warmer than bulb.
 - 2. Secure bulb to clean, straight, horizontal section of suction line using two bulb straps. Do not mount bulb in a trap or at bottom of the line.
 - 3. If external equalizer lines are required, make connection where it will reflect suction-line pressure at bulb location.
- H. Install safety relief valves where required by ASME Boiler and Pressure Vessel Code. Pipe safety-relief-valve discharge line to outside according to ASHRAE 15.
- I. Install moisture/liquid indicators in liquid line at the inlet of the thermostatic expansion valve or at the inlet of the evaporator coil capillary tube.
- J. Install strainers upstream from and adjacent to the following unless they are furnished as an integral assembly for device being protected:
 - 1. Solenoid valves.
 - 2. Thermostatic expansion valves.
 - 3. Hot-gas bypass valves.
 - 4. Compressor.
- K. Install filter dryers in liquid line between compressor and thermostatic expansion valve, and in the suction line at the compressor.
- L. Install receivers sized to accommodate pump-down charge with refrigerant grade service isolation valves.
- M. Install flexible connectors at compressors.

3.3 PIPING INSTALLATION

- A. Refrigerant pipe labeling shall comply with section “230553 Identification for HVAC Piping and Equipment” and be located every 12’ when piping is above ceiling.
- B. Piping insulation shall comply with section “230700 HVAC Insulation”. Insulation shall be minimum 1 ½” thick. All exterior piping shall have an aluminum jacket.
- C. Drawing plans, schematics, and diagrams indicate general location and arrangement of piping systems; indicated locations and arrangements were used to size pipe and calculate friction loss, expansion, pump sizing, and other design considerations. Install piping as indicated unless deviations to layout are approved on Shop Drawings.
- D. Install refrigerant piping according to ASHRAE 15.

- E. Install piping in concealed locations unless otherwise indicated and except in equipment rooms and service areas.
- F. Install piping indicated to be exposed and piping in equipment rooms and service areas at right angles or parallel to building walls. Diagonal runs are prohibited unless specifically indicated otherwise.
- G. Install piping above accessible ceilings to allow sufficient space for ceiling panel removal.
- H. Install piping adjacent to machines to allow service and maintenance.
- I. Install piping free of sags and bends.
- J. Install fittings for changes in direction and branch connections.
- K. Select system components with pressure rating equal to or greater than system operating pressure.
- L. Refer to Division 23 Sections "Direct Digital Control (DDC) for HVAC" for solenoid valve controllers, control wiring, and sequence of operation.
- M. Install piping as short and direct as possible, with a minimum number of joints, elbows, and fittings.
- N. Arrange piping to allow inspection and service of refrigeration equipment. Install valves and specialties in accessible locations to allow for service and inspection. Install access doors or panels as specified in Division 08 Section "Access Doors and Frames" if valves or equipment requiring maintenance is concealed behind finished surfaces.
- O. Install refrigerant piping in protective conduit where installed belowground.
- P. Install refrigerant piping in rigid or flexible conduit in locations where exposed to mechanical injury.
- Q. Slope refrigerant piping as follows:
 - 1. Install horizontal hot-gas discharge piping with a uniform slope downward away from compressor.
 - 2. Install horizontal suction lines with a uniform slope downward to compressor.
 - 3. Install traps and double risers to entrain oil in vertical runs.
 - 4. Liquid lines may be installed level.
- R. When brazing or soldering, remove solenoid-valve coils and sight glasses; also remove valve stems, seats, and packing, and accessible internal parts of refrigerant specialties. Do not apply heat near expansion-valve bulb. Purge piping with N₂ inert gas while brazing/soldering.
- S. Before installation of steel refrigerant piping, clean pipe and fittings using the following procedures:
 - 1. Shot blast the interior of piping.

2. Remove coarse particles of dirt and dust by drawing a clean, lintless cloth through tubing by means of a wire or electrician's tape.
 3. Draw a clean, lintless cloth saturated with trichloroethylene through the tube or pipe. Continue this procedure until cloth is not discolored by dirt.
 4. Draw a clean, lintless cloth, saturated with compressor oil, squeezed dry, through the tube or pipe to remove remaining lint. Inspect tube or pipe visually for remaining dirt and lint.
 5. Finally, draw a clean, dry, lintless cloth through the tube or pipe.
 6. Safety-relief-valve discharge piping is not required to be cleaned but is required to be open to allow unrestricted flow.
- T. Install piping with adequate clearance between pipe and adjacent walls and hangers or between pipes for insulation installation.
- U. Identify refrigerant piping and valves according to Division 23 Section "Identification for HVAC Piping and Equipment."

3.4 PIPE JOINT CONSTRUCTION

- A. Ream ends of pipes and tubes and remove burrs. Bevel plain ends of steel pipe.
- B. Remove scale, slag, dirt, and debris from inside and outside of pipe and fittings before assembly.
- C. Fill pipe and fittings with an inert gas (nitrogen or carbon dioxide), during brazing or welding, to prevent scale formation.
- D. Brazed Joints: Construct joints according to AWS's "Brazing Handbook," Chapter "Pipe and Tube."
 1. Use Type BcuP, copper-phosphorus alloy for joining copper socket fittings with copper pipe.
 2. Use Type BAg, cadmium-free silver alloy for joining copper with bronze or steel.

3.5 HANGERS AND SUPPORTS

- A. Hanger, support, and anchor products are specified in Division 23 Section "Hangers and Supports for HVAC Piping and Equipment."
- B. Install the following pipe attachments:
 1. Adjustable steel clevis hangers for individual horizontal runs less than 20 feet (6 m) long.
 2. Roller hangers and spring hangers for individual horizontal runs 20 feet (6 m) or longer.
 3. Pipe Roller: MSS SP-58, Type 44 for multiple horizontal piping 20 feet (6 m) or longer, supported on a trapeze.
 4. Spring hangers to support vertical runs.
 5. Copper-clad hangers and supports for hangers and supports in direct contact with copper pipe.

- C. Install hangers for copper tubing with the following maximum spacing and minimum rod sizes:
 - 1. NPS 1/2: Maximum span, 60 inches; minimum rod size, 1/4 inch.
 - 2. NPS 5/8: Maximum span, 60 inches; minimum rod size, 1/4 inch.
 - 3. NPS 1: Maximum span, 72 inches; minimum rod size, 1/4 inch.
 - 4. NPS 1-1/4: Maximum span, 96 inches; minimum rod size, 3/8 inch.
 - 5. NPS 1-1/2: Maximum span, 96 inches; minimum rod size, 3/8 inch.
 - 6. NPS 2: Maximum span, 96 inches; minimum rod size, 3/8 inch.
 - 7. NPS 2-1/: Maximum span, 108 inches; minimum rod size, 3/8 inch.
 - 8. NPS 3: Maximum span, 10 feet; minimum rod size, 3/8 inch.
 - 9. NPS 4: Maximum span, 12 feet; minimum rod size, 1/2 inch.

- D. Install hangers for steel piping with the following maximum spacing and minimum rod sizes:
 - 1. NPS 2: Maximum span, 10 feet; minimum rod size, 3/8 inch.
 - 2. NPS 2-1/2: Maximum span, 11 feet; minimum rod size, 3/8 inch.
 - 3. NPS 3: Maximum span, 12 feet; minimum rod size, 3/8 inch.
 - 4. NPS 4: Maximum span, 14 feet; minimum rod size, 1/2 inch.

- E. Support multifloor vertical runs at least at each floor.

3.6 FIELD QUALITY CONTROL

- A. Perform tests and inspections and prepare test reports.

- B. Refrigerant piping shall be installed by technicians certified in accordance with Section 608 of the 1990 Clean Air Act. Copies of each technician's certification shall be provided to the University during the submittal phase.

- C. Technician shall flow dry nitrogen thru refrigerant piping during any brazing or soldering to prevent copper oxidation inside the piping.

- D. Refrigerant Piping Leak Testing:
 - 1. Coordination. Contractor shall schedule vacuum test 72-hours in advance with UMD Project Manager. Test shall be M-F, 7AM-3PM and the test shall commence prior to 11AM.
 - 2. Filter dryer if installed in refrigerant piping and does not have replaceable core. Filter Dryer shall remain in place open to the system during evacuation to allow dehydration of the desiccant core
 - 3. Vacuum Pump Requirements. $\text{Tons} / 7 = \text{Vacuum Pump CFM Required}$. Manifold shall connect vacuum pump to both high and low side of each unit. All isolation valves in the refrigerant piping, gauge manifolds, etc shall be open during evacuation to prevent un-evacuated pockets. One-Standard Port (1/4" Male Flare) on Common Manifold shall be reserved for University Project Manager or delegate to attach Micron Meter. After Contractor and UMD concur that the evacuation level is 500 microns or lower via attached Micron Meters, the vacuum pump manifold connection shall be closed and then shut down. The standing vacuum test will then commence with a 5-minute settling time for the micron meter. The micron standing test beginning reading shall then be recorded. If after two hours the micron level has not increased more than 50 microns above the

standing test beginning readings the unit vacuum can be broken with refrigerant gas. If the micron reading increases more than 50 microns and settles then the system will be deemed to have moisture. To remove the moisture the system vacuum shall be broken with dry nitrogen and the system shall be evacuated again. This procedure shall be repeated until the each system passes the standing vacuum test. If the micron reading increases more than 50 microns and continues to rise the system a leak exists and must be located and corrected.

4. After the UMD approves standing vacuum test indicating it has passed. Vacuum shall be broken with refrigerant to a level greater than 2psig
5. Replace filter dryer(s) if pressure drop across drier exceeds manufacturer's recommendations.

E. Tests and Inspections:

1. Comply with ASME B31.5, Chapter VI.
2. Test refrigerant piping, specialties, and receivers. Isolate compressor, condenser, evaporator, and safety devices from test pressure if they are not rated above the test pressure.
3. Test high- and low-pressure side piping of each system separately at not less than the pressures indicated in Part 1 "Performance Requirements" Article.
 - a. Fill system with nitrogen to the required test pressure.
 - b. System shall maintain test pressure at the manifold gage throughout duration of test.
 - c. Test joints and fittings with electronic leak detector or by brushing a small amount of soap and glycerin solution over joints.
 - d. Remake leaking joints using new materials, and retest until satisfactory results are achieved.
 - e. Pressure test at test pressure: Standing test for minimum of 24 hours with no greater than 1% loss in pressure.

3.7 REFRIGERANT REMOVAL

- A. Facilities Management HVAC Systems maintains EPA refrigerant database. FM HVAC Systems Associate Director is the UMCP campus Refrigerant manager. Contractors removing or installing systems that utilize refrigerants must submit copies of EPA refrigerant technician certifications for input into the database. A contractor refrigerant disposal form or contractor refrigerant installation form is to be prepared and submitted for each piece of equipment: model number, serial number, voltage, phase, location, refrigerant types and quantities are to be provided for input into refrigerant database
- B. Whenever equipment is being removed, HVAC Systems is to recover refrigerant or contractor is to turn over recovered refrigerant to the FM HVAC Systems Unit. Where FM HVAC Systems does not require return of refrigerant the contractor shall dispose of the refrigerant following EPA Section 608 requirements and provide to the University FM HVAC Systems the quantity of refrigerant removed for record.

3.8 SYSTEM CHARGING

- A. Charge system using the following procedures:
 - 1. Install core in filter dryers after leak test but before evacuation.
 - 2. Evacuate entire refrigerant system with a vacuum pump to 500 micrometers. If vacuum holds for 24 hours, system is ready for charging.
 - 3. Break vacuum with refrigerant gas, allowing pressure to build up to 2 psig.
 - 4. Charge system with a new filter-dryer core in charging line.

3.9 ADJUSTING

- A. Adjust thermostatic expansion valve to obtain proper evaporator superheat.
- B. Adjust high- and low-pressure switch settings to avoid short cycling in response to fluctuating suction pressure.
- C. Adjust set-point temperature of air-conditioning or chilled-water controllers to the system design temperature.
- D. Perform the following adjustments before operating the refrigeration system, according to manufacturer's written instructions:
 - 1. Open shutoff valves in condenser water circuit.
 - 2. Verify that compressor oil level is correct.
 - 3. Open compressor suction and discharge valves.
 - 4. Open refrigerant valves except bypass valves that are used for other purposes.
 - 5. Check open compressor-motor alignment and verify lubrication for motors and bearings.
- E. Replace core of replaceable filter dryer after system has been adjusted and after design flow rates and pressures are established.

END OF SECTION 232300

SECTION 232500 - HVAC WATER TREATMENT & FLUSHING

PART 1 - GENERAL

1.1 RELATED DOCUMENTS

- A. Drawings and general provisions of the Contract, including General and Supplementary Conditions and Division 01 Specification Sections, apply to this Section.

1.2 SUMMARY

- A. Section includes the following HVAC water-treatment systems:
 - 1. Pipe system flushing
 - 2. Chemicals.

1.3 DEFINITIONS

- A. PPM: Parts per million.

1.4 ACTION SUBMITTALS

- A. Product Data: Include rated capacities, operating characteristics, and furnished specialties and accessories for the following products:
 - 1. Flushing plan including sectional flushing recommendations and valving and bypass layout.
 - 2. Temporary Pump (as applicable)
 - 3. Post pipe flush report.
 - 4. Chemical Treatment Contractor Qualifications.
 - 5. Bypass feeders.
 - 6. Water meters.
 - 7. Pump used in circulation
 - 8. Product data for cleaning (pretreatment)
 - 9. Product data corrosion inhibitors
 - 10. Chemical material safety data sheets.

1.5 INFORMATIONAL SUBMITTALS

- A. Water-Analysis Provider Qualifications: Verification of experience and capability of HVAC water-treatment service provider.
- B. Field quality-control reports.

- C. Water Analysis: Illustrate water quality available at Project site.

1.6 REGULATORY REQUIREMENTS

- A. Conform to applicable EPA codes for addition of non-potable chemicals to building mechanical systems and for discharge to public sewage systems.

1.7 QUALITY ASSURANCE

- A. HVAC Water-Treatment Service Provider Qualifications: An experienced HVAC water-treatment service provider, capable of analyzing water qualities, installing water-treatment equipment, and applying water treatment as specified in this Section.

PART 2 - PRODUCTS

2.1 HVAC WATER-TREATMENT MANUFACTURERS

- A. Service Companies
 1. ARC – water treatment company of Maryland, Inc , Jessup, MD 20794
 2. Chemstar Water Treatment Professional, Baltimore, MD 21220
 3. Nalco (EcoLab)
 4. Aqua-Chem, Inc

2.2 PERFORMANCE REQUIREMENTS

- A. Provide all hardware, chemicals, and other material necessary to maintain HVAC water quality in all systems as indicated in this Specification. Water quality for HVAC systems shall minimize corrosion, scale buildup, and biological growth for optimum efficiency of HVAC equipment without creating a hazard to operating personnel or to the environment.
- B. Base HVAC water treatment on quality of water available at Project site, HVAC system equipment material characteristics and functional performance characteristics, operating personnel capabilities, and requirements and guidelines of authorities having jurisdiction.
- C. Closed hydronic systems, including hot-water heating below 250 deg F , chilled water, dual-temperature water, glycol heating, and glycol cooling shall have the following water qualities:
 1. pH: Maintain a value within 7.0 to 10.0.
 2. “P” Alkalinity: Maintain a value within 100 to 500 ppm.
 3. Steel Corrosion Inhibitors: Provide sufficient inhibitors to limit mild steel corrosion to 0.1 mils per year. Maintain soluble iron concentrations at or below 3 mg/L.
 - a. Note: Corrosion limits may vary depending the thickness of pipe/equipment in the hydronic system. The above value is a guideline. Actual value shall be provided by water treatment contractor.

4. Yellow Metal Corrosion Inhibitor: Provide sufficient copper and brass corrosion inhibitors to limit copper corrosion to 0.2 mils per year. Maintain soluble copper concentrations at or below 1 mg/L.
 - a. Note: Corrosion limits may vary depending on the thickness of pipe/equipment in the hydronic system. The above value is a guideline. Actual value shall be provided by water treatment contractor.
5. Scale Control: Provide softened water for initial fill and makeup. Where softened water is not used, provide sufficient scale inhibitors to prevent formation of scale and maintain all scale-forming material in solution.
6. Dispersants: Provide sufficient dispersants to prevent sedimentation of fine particulate matter.
7. Microbiological Limits:
 - a. Total Aerobic Plate Count: Maintain a maximum value of 1000 organisms/mL.
 - b. Total Anaerobic Plate Count: Maintain a maximum value of 100 organisms/mL.
 - c. Nitrate Reducers: Maintain a maximum value of 100 organisms/mL.
 - d. Sulfate Reducers: Maintain a maximum value of 0 organisms/mL.
 - e. Iron Bacteria: Maintain a maximum value of 0 organisms/mL.
8. Treatment – Corrosion Inhibitors
 - 1) *Chemicals shall be recommended by water-treatment system manufacturer that are compatible with the piping system components and connected equipment, and that can attain water quality specified.*
 - b. Low Temperature hot water, closed cooling and chilled water – Mixture of sodium nitrite, borax and molybdate with other copper alloy inhibitor. For chilled water (where nitrite based inhibitors can not be used) - a non-nitrite program of phosphate, polymer borate and copper inhibitors: non-oxidizing, non-cationic biocide.
 - 1) ARC Water Treatment – ARNIT closed loop corrosion inhibitor
 - 2) Chemstar Water Treatment – CHEMSTAR 634
 - c. Glycol low temperature – Ethylene glycol with buffered phosphate based corrosion inhibitor with copper alloy inhibitor in deionized water, if water chloride levels are 750ppm and contains hard water ions.

2.3 MANUAL CHEMICAL-FEED EQUIPMENT

- A. Bypass Feeders: Steel, with corrosion-resistant exterior coating, minimum 3-1/2-inch fill opening in the top, and NPS $\frac{3}{4}$ bottom inlet and top side outlet. Provide quarter- turn or threaded fill cap with gasket seal and diaphragm arranged to lock the top onto the feeder when exposed to system pressure in the vessel. Provide a NPS $\frac{3}{4}$ IN quarter-turn valve on inlet and outlet.
 1. Capacity: 5 gal.
 2. Minimum Working Pressure: 175 psig

2.4 AUTOMATIC CHEMICAL-FEED EQUIPMENT

- A. Water Meter, Oscillating Piston:

1. AWWA C700, oscillating-piston, magnetic-drive, totalization meter.
2. Body: Bronze.
3. Minimum Working-Pressure Rating: 150 psig
4. Maximum Pressure Loss at Design Flow: 3 psig
5. End Connections: Threaded.
6. Controls: Flow-control switch with normally open contacts, rated for maximum 10 A, 250-V ac, that will momentarily close at adjustable increments of total flow.

2.5 CHEMICAL-TREATMENT TEST EQUIPMENT

- A. Test Kit: Manufacturer-recommended equipment and chemicals in a wall-mounted cabinet for testing pH, TSS, inhibitor, chloride, alkalinity, and hardness; sulfite and testable polymer tests for high-pressure boilers; and oxidizing biocide test for open cooling systems.
- B. Sample Cooler:
 1. Tube: Sample.
 - a. Size: NPS 1/4 tubing.
 - b. Material: ASTM A666, Type 316 stainless steel.
 - c. Pressure Rating: Minimum 2000 psig.
 - d. Temperature Rating: Minimum 850 deg F.
 2. Shell: Cooling water.
 - a. Material: ASTM A666, Type 304 stainless steel.
 - b. Pressure Rating: Minimum 250 psig .
 - c. Temperature Rating: Minimum 450 deg F .
 3. Capacities and Characteristics:
 - a. Tube: Sample.
 - 1) Flow Rate: 0.25 gpm
 - 2) Entering Temperature: 400 deg F
 - 3) Leaving Temperature: 88 deg F
 - 4) Pressure Loss: 6.5 psig
 - b. Shell: Cooling water.
 - 1) Flow Rate: 3 gpm
 - 2) Entering Temperature: 70 deg F
 - 3) Pressure Loss: 1.0 psig
- C. Corrosion Test-Coupon Assembly: Constructed of corrosive-resistant material, complete with piping, valves, and mild steel and copper coupons. Locate copper coupon downstream from mild steel coupon in the test-coupon assembly.
 1. Two - station rack for closed-loop systems.

2.6 CHEMICALS

- A. Chemicals shall be as recommended by water-treatment system manufacturer that are compatible with piping system components and connected equipment and that can attain water quality specified in "Performance Requirements" Article.

2.7 ETHYLENE GLYCOL AND PROPYLENE GLYCOL

- A. Use "Environmentally Friendly" glycol.
- B. Coordinate compatibility of glycol with material used in piping, valves, equipment and accessories.
- C. Provide glycol feed system.

PART 3 - EXECUTION

3.1 WATER ANALYSIS

- A. Perform an analysis of supply water to determine quality of water available at Project site.

3.2 INSTALLATION

- A. Install chemical-application equipment on concrete bases, level and plumb. Maintain manufacturer's recommended clearances. Arrange units, so controls and devices that require servicing are accessible. Anchor chemical tanks and floor-mounting accessories to substrate. Install all chemical application equipment within a spill-containment area without floor drains.
- B. Install water-testing equipment on wall near water-chemical-application equipment.
- C. Install interconnecting control wiring for chemical-treatment controls and sensors.
- D. Mount sensors and injectors in piping circuits.
- E. Bypass Feeders: Install in closed hydronic systems, including hot-water heating, chilled water, dual-temperature water, glycol heating, and glycol cooling, and equip with the following:
 - 1. Install bypass feeder in a bypass circuit around circulating pumps unless otherwise indicated on Drawings.
 - 2. Install water meter in makeup-water supply.
 - 3. Install test-coupon assembly in bypass circuit around circulating pumps unless otherwise indicated on Drawings.
 - 4. Install a gate or full-port ball isolation valves on inlet, outlet, and drain below feeder inlet.
 - 5. Install a swing check on inlet after the isolation valve.

3.3 PIPING CONNECTIONS

- A. Piping installation requirements are specified in other Sections. Drawings indicate general arrangement of piping, fittings, and specialties.
- B. Where installing piping adjacent to equipment, allow space for service and maintenance.
- C. Make piping connections between HVAC water-treatment equipment and dissimilar-metal piping with dielectric fittings. Dielectric fittings are specified in Section 232113 "Hydronic Piping."
- D. Install shutoff valves on HVAC water-treatment equipment inlet and outlet. Metal general-duty valves are specified in Section 230523.11 "Globe Valves for HVAC Piping," Section 230523.12 "Ball Valves for HVAC Piping," Section 230523.13 "Butterfly Valves for HVAC Piping," and Section 230523.15 "Gate Valves for HVAC Piping."
- E. See Section 221119 "Domestic Water Piping Specialties" for backflow preventers required in makeup-water connections to potable-water systems.

3.4 PIPING SYSTEM FLUSHING REQUIREMENTS

- A. The following guidelines have been developed for Hydronic Piping and Vessels Flushing and Cleaning Procedures provided by UMD. The following preliminary guidelines are offered to assist Design Engineers in developing detailed flushing specifications for the Glycol, HWS, CHWS and Condenser Water systems. The Contractor shall submit a detailed written Flushing plan including shop drawings depicting locations of bypasses, strainers, vents, drains, isolation valves and temporary spool pieces for review and approval by UMD and the Engineer of Record.
- B. Flushing & Treatment Requirements:
 - 1. All new metallic hydronic piping systems shall be thoroughly flushed and treated prior to putting the system into service or connecting to an existing building hydronic system.
 - 2. Flushing and Treatment shall be witnessed by representatives of the Mechanical Contractor, Chemical Treatment Contractor, EOR, UMD & CX Agency.
 - 3. The layout and complexity of the piping system may require the system to be separately flushed in sections IE: Carbon steel mains vs Copper branch lines. The EOR shall review the design documents piping layout and a meeting shall be set up with the Contractor & UMD to determine if sectional flushing shall occur.
- C. Chemical & Treatment Contractor:
 - 1. The Contractor shall submit to the EOR & UMD the Proposed Chemical Treatment Contractor Company information and Qualifications along with the proposed chemical cleaning & inhibitor brands and concentrations of the chemicals for review and approval.
 - 2. The University of Maryland System utilizes pre-approved Chemical Treatment companies on all of its campuses. The Contractor shall obtain from UMD via a Request for Information (RFI) for the list of approved Chemical Treatment companies.
- D. System Flushing Pumps:
 - 1. Temporary Pump Systems:

- a. The incorporation and use of temporary pump systems is recommended for the flushing & cleaning process. The Contractor shall size the temporary pump system to ensure a fluid velocity of 6 FPS through the largest pipe diameter in the system.
 - b. The Contractor shall submit documentation to the EOR & UMD for approval of the proposed temporary pump system. This shall include pump curves, flow meters to prove the required velocity, pressure gauges, connection details and temporary power requirements along with a written description and photos of the proposed temporary pump system.
2. Permanent Facility Pump Systems
- a. In the event temporary pumps cannot be utilized for the flushing and cleaning process the New permanent facility pump systems may be used only with prior approval of the EOR & UMD. The Contractor shall submit documentation to the EOR & UMD for approval of the proposed use of the Permanent Facility pump system. This shall include verification that the permanent facility pump system is capable of achieving the required fluid velocity of 6 FPS through the largest pipe diameter in the system, pump curves, flow meters to prove the required velocity, pressure gauges, connection details and power requirements along with a written description and photos of the proposed Permanent Facility pump system.
 - b. In Exchange for the use of the permanent facility pump system, The Contractor shall engage the Pump Manufacturer at the end of the flushing process to disassemble the pump bodies and fully inspect the condition of the impellers, seals, bearings and motors for any damage caused by the flushing process. The Pump Manufacturer shall provide a written report with documenting photos of the condition of the pump system to the EOR & UMD. The permanent facility pumps must be in new or as new condition and unconditionally warranted for a period of 2 years from the date of Project Substantial Completion. In the event a pump or pumps fail and is proven to be a result of the flushing process during the 2 year warranty period the Contractor shall provide an additional 2 year extended warranty from the date of repair / replacement on the failed pump system
- E. Bypasses, Vents, Drains, Strainers, Isolation Valves, Temporary Spool Pieces & Hoses:
1. The Contractor shall prepare the piping system to ensure equipment and fragile devices are protected from damage caused by the flushing process
 2. The Contractor shall Isolate & Bypass all Major Equipment, Chillers, AHU coils, heat exchangers, ancillary equipment (IE: VAV's, FCU's CUH's, Fin tube radiators Etc.) control valves, check valves, insertion type & inline flow meters and any other fragile device that may be damaged as a result of the flushing process. The Contractor shall incorporate the use of Line Size temporary flanged / union spool pieces in locations where fragile devices were removed.
 3. The Contractor shall install high point air vents and low point drains in locations depicted on the contract drawings. The layout of the piping system may require additional secondary high point vents and low point drains to ensure the system can be fully vented and drained during the flushing process. The Contractor shall depict on the Flushing procedure shop drawings all required and secondary vents & drains. Secondary vents and drains shall be at No additional costs to the Owner.
 4. The Contractor shall provide and install strainers in locations depicted on the Contract drawings. The layout of the piping system may require additional secondary strainers in locations not depicted on the contract drawings to ensure debris is captured properly. The Contractor shall provide and install stainless steel temporary strainer mesh screens that

will be replaced with new permanent strainer mesh screens after the flushing procedure is completed and accepted.

F. Pre-Flushing Inspections

1. The Contractor shall perform Quality Assurance inspections of the piping systems during the installation process to ensure the piping systems are free from debris such as welding rods, paper/plastic trash, wood, cloth rags or any other trash or debris.
2. When all preparation work of the piping system is completed the Contractor shall notify the EOR, UMD & the Third Party CX Agency and request an inspection of the piping system and temporary measures taken. Upon inspection and Written approval, the Contractor shall commence with the flushing operation.

3.5 PIPE FLUSHING PROCEDURE

- A. The following defines the process for executing pipe flushing when criteria noted in section 3.4 above are satisfied.
1. Fill system with fresh water and circulate for 12-24 hours and flush to remove large sediment first.
 2. Backflow preventer shall be installed on domestic water make water system.
 3. Verify system drain downs area near an approved sanitary sewer drain.
- B. Drain system from all lowest possible point and refill with fresh water.
- C. Add a System Cleaner: liquid alkaline compound with emulsifying agents and detergents to remove grease and petroleum products. Closed system cleaner at a dosage of 15 gallons per 1000 gallon system (or recommended dosage per water treatment contractor). And circulate for 24 hours.
1. Note: all new installed equipment (such as VAV coils, HX's, expansion tanks, etc) which are not to be subjected to chemical cleaning and flushing, shall be either disconnected from the piping. Or add by-pass loops at each branch pipe to ensure continuous circulation of flushing fluids. Circulating pump must run continuously during the entire cleaning and flushing procedure to assure proper cleaning)
- D. Drain system from all lowest points until the pH is equal to fresh potable water make up (>8.0).
- E. Circulate the system water again after flushing for 12 hours, then drain system again.
- F. If system water is clean at test valves on lower section of system proceed to next step. If the system is still turbid fill circulate for another 12 hours and flush until it is clear.
- G. Refill system with fresh water and add corrosion inhibitor to system water to achieve the desired residual (50-150ppm).
- H. The system must be tested after 2 weeks of operation to ensure the chemical residual is adequate and maintained.
- I. Submit written proof of cleaning and flushing. Report is to include largest main, circulating pump size (flow and head), system volume (in gallons), amount of cleaning agent added (in

gallon), flush start date and time and end date and time, amount of chemical added, water quality parameters and chemical residual after 2 week operation period.

1. Provide redline drawings highlighting the piping that was flushed and locations of bypass.

J. The water treatment contractor shall test water quality in existing systems and submit report to UMD O&M prior to opening up the new system to the existing system.

3.6 FIELD QUALITY CONTROL

A. Testing Agency: Engage a qualified testing agency to perform tests and inspections.

B. Manufacturer's Field Service: Engage a factory-authorized service representative to test and inspect components, assemblies, and equipment installations, including connections.

C. Tests and Inspections:

1. Inspect field-assembled components and equipment installation, including piping and electrical connections.

2. Inspect piping and equipment to determine that systems and equipment have been cleaned, flushed, and filled with water, and are fully operational before introducing chemicals for water-treatment system.

3. Place HVAC water-treatment system into operation, and calibrate controls during the preliminary phase of HVAC system's startup procedures.

4. Do not enclose, cover, or put piping into operation until it is tested and satisfactory test results are achieved.

5. Test for leaks and defects. If testing is performed in segments, submit separate report for each test, complete with diagram of portion of piping tested.

6. Leave uncovered and unconcealed new, altered, extended, and replaced water piping until it has been tested and approved. Expose work that has been covered or concealed before it has been tested and approved.

7. Cap and subject piping to static water pressure of 50 psig above operating pressure, without exceeding pressure rating of piping system materials. Isolate test source and allow test pressure to stand for four hours. Leaks and loss in test pressure constitute defects.

8. Repair leaks and defects with new materials, and retest piping until no leaks exist.

D. Equipment will be considered defective if it does not pass tests and inspections.

E. Prepare test and inspection reports.

F. At four-week intervals following Substantial Completion, perform separate water analyses on hydronic systems to show that automatic chemical-feed systems are maintaining water quality within performance requirements specified in this Section. Submit written reports of water analysis, advising Owner of changes necessary to adhere to "Performance Requirements" Article.

G. Comply with ASTM D3370 and with the following standards:

1. Silica: ASTM D859.
2. Steam System: ASTM D1066.
3. Acidity and Alkalinity: ASTM D1067.
4. Iron: ASTM D1068.
5. Water Hardness: ASTM D1126.

3.7 DEMONSTRATION

- A. Train Owner's maintenance personnel to adjust, operate, and maintain HVAC water-treatment systems and equipment.

3.8 FINAL CONNECTION TO SCUB OR SITE UTILITIES

- A. Do not circulate any water from the site chilled and high temperature hot water mains until the SCUB water treatment contractor has certified the water quality of both sides of the site utility isolation valves.
- B. After connection to plant utilities are achieved remove temporary bypass pipes and cap.

END OF SECTION 232500

SECTION 233113 - METAL DUCTS

PART 1 - GENERAL

1.1 RELATED DOCUMENTS

- A. Drawings and general provisions of the Contract, including General and Supplementary Conditions and Division 01 Specification Sections, apply to this Section.

1.2 SUMMARY

- A. Section Includes:

1. Single-wall rectangular ducts and fittings.
2. Double-wall rectangular ducts and fittings.
3. Single-wall round ducts and fittings.
4. Double-wall round ducts and fittings.
5. Sheet metal materials.
6. Duct liner.
7. Sealants and gaskets.
8. Hangers and supports.

- B. Related Sections:

1. Division 23 Section "Testing, Adjusting, and Balancing for HVAC" for testing, adjusting, and balancing requirements for metal ducts.
2. Division 23 Section "Air Duct Accessories" for dampers, sound-control devices, duct-mounting access doors and panels, turning vanes, and flexible ducts.

1.3 PERFORMANCE REQUIREMENTS

- A. Delegated Duct Design: Duct construction, including sheet metal thicknesses, seam and joint construction, reinforcements, and hangers and supports, shall comply with SMACNA's "HVAC Duct Construction Standards - Metal and Flexible" and performance requirements and design criteria indicated in "Duct Schedule" Article.
- B. Structural Performance: Duct hangers and supports shall withstand the effects of gravity loads and stresses within limits and under conditions described in SMACNA's "HVAC Duct Construction Standards - Metal and Flexible."
 1. Refer to Spec 230548 – Vibration and Seismic Controls For HVAC
- C. Airstream Surfaces: Surfaces in contact with the airstream shall comply with requirements in ASHRAE 62.1-2004.

1.4 SUBMITTALS

- A. Product Data: For each type of the following products:
1. Liners and adhesives.
 2. Sealants and gaskets.
 3. Documentation of work performed for compliance with ASHRAE/IESNA 90.1-2004, Section 6.4.4.2.2 - "Duct Leakage Tests."
 4. Documentation of work performed for compliance with ASHRAE 62.1-2004, Section 7.2.4 - "Ventilation System Start-Up."
 5. For adhesives and sealants, including printed statement of VOC content.
- B. Shop Drawings:
1. Fabrication, assembly, and installation, including plans, elevations, sections, components, and attachments to other work.
 2. Factory- and shop-fabricated ducts and fittings.
 3. Duct layout indicating sizes, configuration, liner material, and static-pressure classes.
 4. Elevation of top of ducts.
 5. Dimensions of main duct runs from building grid lines.
 6. Fittings.
 7. Reinforcement and spacing.
 8. Seam and joint construction.
 9. Penetrations through fire-rated and other partitions.
 10. Equipment installation based on equipment being used on Project.
 11. Locations for duct accessories, including dampers, turning vanes, and access doors and panels.
 12. Hangers and supports, including methods for duct and building attachment and vibration isolation.
- C. Delegated-Design Submittal:
1. Sheet metal thicknesses.
 2. Joint and seam construction and sealing.
 3. Reinforcement details and spacing.
 4. Materials, fabrication, assembly, and spacing of hangers and supports.
 5. Design Calculations: Calculations for selecting hangers and supports.
- D. Coordination Drawings: Plans, drawn to scale, on which the following items are shown and coordinated with each other, using input from installers of the items involved:
1. Duct installation in congested spaces, indicating coordination with general construction, building components, and other building services. Indicate proposed changes to duct layout.
 2. Suspended ceiling components.
 3. Structural members to which duct will be attached.
 4. Size and location of initial access modules for acoustical tile.
 5. Penetrations of smoke barriers and fire-rated construction.
 6. Items penetrating finished ceiling including the following:

- a. Lighting fixtures.
 - b. Air outlets and inlets.
 - c. Speakers.
 - d. Sprinklers.
 - e. Access panels.
 - f. Perimeter moldings.
- E. Welding certificates.
- F. Field quality-control reports.

1.5 QUALITY ASSURANCE

- A. Welding Qualifications: Qualify procedures and personnel according to the following:
- 1. AWS D1.1/D1.1M, "Structural Welding Code - Steel," for hangers and supports.
 - 2. AWS D9.1M/D9.1, "Sheet Metal Welding Code," for duct joint and seam welding.
- B. ASHRAE Compliance: Applicable requirements in ASHRAE 62.1-2004, Section 5 - "Systems and Equipment" and Section 7 - "Construction and System Start-Up."
- C. ASHRAE/IESNA Compliance: Applicable requirements in ASHRAE/IESNA 90.1-2004, Section 6.4.4 - "HVAC System Construction and Insulation."
- D. Duct testing and report shall be Compliance: SMACNA HVAC Air Duct Leakage Test Manual latest version.

PART 2 - PRODUCTS

2.1 SINGLE-WALL RECTANGULAR DUCTS AND FITTINGS

- A. General Fabrication Requirements: Comply with SMACNA's "HVAC Duct Construction Standards - Metal and Flexible" based on indicated static-pressure class unless otherwise indicated.
- B. Transverse Joints: Select joint types and fabricate according to SMACNA's "HVAC Duct Construction Standards - Metal and Flexible," Figure 1-4, "Transverse (Girth) Joints," for static-pressure class, applicable sealing requirements, materials involved, duct-support intervals, and other provisions in SMACNA's "HVAC Duct Construction Standards - Metal and Flexible."
- C. Longitudinal Seams: Select seam types and fabricate according to SMACNA's "HVAC Duct Construction Standards - Metal and Flexible," Figure 1-5, "Longitudinal Seams - Rectangular Ducts," for static-pressure class, applicable sealing requirements, materials involved, duct-support intervals, and other provisions in SMACNA's "HVAC Duct Construction Standards - Metal and Flexible."

- D. Elbows, Transitions, Offsets, Branch Connections, and Other Duct Construction: Select types and fabricate according to SMACNA's "HVAC Duct Construction Standards - Metal and Flexible," Chapter 2, "Fittings and Other Construction," for static-pressure class, applicable sealing requirements, materials involved, duct-support intervals, and other provisions in SMACNA's "HVAC Duct Construction Standards - Metal and Flexible."

2.2 DOUBLE-WALL RECTANGULAR DUCTS AND FITTINGS

- A. Manufacturers: Subject to compliance with requirements, provide products by one of the following:
 - 1. McGill AirFlow LLC.
 - 2. Sheet Metal Connectors, Inc.
- B. Rectangular Ducts: Fabricate ducts with indicated dimensions for the inner duct.
- C. Outer Duct: Comply with SMACNA's "HVAC Duct Construction Standards - Metal and Flexible" based on indicated static-pressure class unless otherwise indicated.
- D. Transverse Joints: Select joint types and fabricate according to SMACNA's "HVAC Duct Construction Standards - Metal and Flexible," Figure 1-4, "Transverse (Girth) Joints," for static-pressure class, applicable sealing requirements, materials involved, duct-support intervals, and other provisions in SMACNA's "HVAC Duct Construction Standards - Metal and Flexible."
- E. Longitudinal Seams: Select seam types and fabricate according to SMACNA's "HVAC Duct Construction Standards - Metal and Flexible," Figure 1-5, "Longitudinal Seams - Rectangular Ducts," for static-pressure class, applicable sealing requirements, materials involved, duct-support intervals, and other provisions in SMACNA's "HVAC Duct Construction Standards - Metal and Flexible."
- F. Interstitial Insulation: Fibrous-glass liner complying with ASTM C 1071, NFPA 90A, or NFPA 90B; and with NAIMA AH124, "Fibrous Glass Duct Liner Standard."
 - 1. Maximum Thermal Conductivity: 0.27 Btu x in./h x sq. ft. x deg F at 75 deg F mean temperature.
 - 2. Install spacers that position the inner duct at uniform distance from outer duct without compressing insulation.
 - 3. Coat insulation with antimicrobial coating.
 - 4. Cover insulation with polyester film complying with UL 181, Class 1. If inner duct is perforated.
- G. Interstitial Insulation: Flexible elastomeric duct liner complying with ASTM C 534, Type II for sheet materials, and with NFPA 90A or NFPA 90B.
 - 1. Maximum Thermal Conductivity: 0.25 Btu x in./h x sq. ft. x deg F at 75 deg F mean temperature.
- H. Inner Duct:

1. Acoustical (Noise Control) - Minimum 0.028-inch perforated galvanized sheet steel having 3/32-inch- diameter perforations, with overall open area of 23 percent.
 2. Thermal (Temperature Control) – Minimum 0.028 inch solid inner shell – galvanized sheet metal.
- I. Formed-on Transverse Joints (Flanges): Select joint types and fabricate according to SMACNA's "HVAC Duct Construction Standards - Metal and Flexible," Figure 1-4, "Traverse (Girth) Joints," for static-pressure class, applicable sealing requirements, materials involved, duct-support intervals, and other provisions in SMACNA's "HVAC Duct Construction Standards - Metal and Flexible."
 - J. Longitudinal Seams: Select seam types and fabricate according to SMACNA's "HVAC Duct Construction Standards - Metal and Flexible," Figure 1-5, "Longitudinal Seams - Rectangular Ducts," for static-pressure class, applicable sealing requirements, materials involved, duct-support intervals, and other provisions in SMACNA's "HVAC Duct Construction Standards - Metal and Flexible."

2.3 SINGLE-WALL ROUND DUCTS AND FITTINGS

- A. General Fabrication Requirements: Comply with SMACNA's "HVAC Duct Construction Standards - Metal and Flexible," Chapter 3, "Round, Oval, and Flexible Duct," based on indicated static-pressure class unless otherwise indicated.
 1. Manufacturers: Subject to compliance with requirements, provide products by one of the following:
 - a. Lindab Inc.
 - b. McGill AirFlow LLC.
 - c. SEMCO Incorporated.
 - d. Sheet Metal Connectors, Inc.
 - e. Spiral Manufacturing Co., Inc.
- B. Flat-Oval Ducts: Indicated dimensions are the duct width (major dimension) and diameter of the round sides connecting the flat portions of the duct (minor dimension).
- C. Transverse Joints: Select joint types and fabricate according to SMACNA's "HVAC Duct Construction Standards - Metal and Flexible," Figure 3-2, "Transverse Joints - Round Duct," for static-pressure class, applicable sealing requirements, materials involved, duct-support intervals, and other provisions in SMACNA's "HVAC Duct Construction Standards - Metal and Flexible."
 1. Transverse Joints in Ducts Larger Than 60 Inches in Diameter: Flanged.
- D. Longitudinal Seams: Select seam types and fabricate according to SMACNA's "HVAC Duct Construction Standards - Metal and Flexible," Figure 3-1, "Seams - Round Duct and Fittings," for static-pressure class, applicable sealing requirements, materials involved, duct-support intervals, and other provisions in SMACNA's "HVAC Duct Construction Standards - Metal and Flexible."

1. Fabricate round ducts larger than 90 inches in diameter with butt-welded longitudinal seams.
 2. Fabricate flat-oval ducts larger than 72 inches in width (major dimension) with butt-welded longitudinal seams.
- E. Tees and Laterals: Select types and fabricate according to SMACNA's "HVAC Duct Construction Standards - Metal and Flexible," Figure 3-4, "90 Degree Tees and Laterals," and Figure 3-5, "Conical Tees," for static-pressure class, applicable sealing requirements, materials involved, duct-support intervals, and other provisions in SMACNA's "HVAC Duct Construction Standards - Metal and Flexible."

2.4 DOUBLE-WALL ROUND DUCTS AND FITTINGS

- A. Manufacturers: Subject to compliance with requirements, provide products by one of the following:
1. Lindab Inc.
 2. McGill AirFlow LLC.
 3. SEMCO Incorporated.
 4. Sheet Metal Connectors, Inc.
- B. Flat-Oval Ducts: Indicated dimensions are the duct width (major dimension) and diameter of the round sides connecting the flat portions of the duct (minor dimension) of the inner duct.
- C. Outer Duct: Comply with SMACNA's "HVAC Duct Construction Standards - Metal and Flexible," Chapter 3, "Round, Oval, and Flexible Duct," based on static-pressure class unless otherwise indicated.
1. Transverse Joints: Select joint types and fabricate according to SMACNA's "HVAC Duct Construction Standards - Metal and Flexible," Figure 3-2, "Transverse Joints - Round Duct," for static-pressure class, applicable sealing requirements, materials involved, duct-support intervals, and other provisions in SMACNA's "HVAC Duct Construction Standards - Metal and Flexible."
 - a. Transverse Joints in Ducts Larger Than 60 Inches in Diameter: Flanged.
 2. Longitudinal Seams: Select seam types and fabricate according to SMACNA's "HVAC Duct Construction Standards - Metal and Flexible," Figure 3-1, "Seams - Round Duct and Fittings," for static-pressure class, applicable sealing requirements, materials involved, duct-support intervals, and other provisions in SMACNA's "HVAC Duct Construction Standards - Metal and Flexible."
 - a. Fabricate round ducts larger than 90 inches in diameter with butt-welded longitudinal seams.
 - b. Fabricate flat-oval ducts larger than 72 inches in width (major dimension) with butt-welded longitudinal seams.
 3. Tees and Laterals: Select types and fabricate according to SMACNA's "HVAC Duct Construction Standards - Metal and Flexible," Figure 3-4, "90 Degree Tees and Laterals,"

and Figure 3-5, "Conical Tees," for static-pressure class, applicable sealing requirements, materials involved, duct-support intervals, and other provisions in SMACNA's "HVAC Duct Construction Standards - Metal and Flexible."

- D. Inner Duct:
 - 1. Acoustical (Noise Control) - Minimum 0.028-inch perforated galvanized sheet steel having 3/32-inch- diameter perforations, with overall open area of 23 percent.
 - 2. Thermal (Temperature Control) – Minimum 0.028 inch solid inner shell – galvanized sheet metal.

- E. Interstitial Insulation: Fibrous-glass liner complying with ASTM C 1071, NFPA 90A, or NFPA 90B; and with NAIMA AH124, "Fibrous Glass Duct Liner Standard."
 - 1. Maximum Thermal Conductivity: 0.27 Btu x in./h x sq. ft. x deg F at 75 deg F mean temperature.
 - 2. Install spacers that position the inner duct at uniform distance from outer duct without compressing insulation.
 - 3. Coat insulation with antimicrobial coating.
 - 4. Cover insulation with polyester film complying with UL 181, Class 1. If inner duct is perforated.

- F. Interstitial Insulation: Flexible elastomeric duct liner complying with ASTM C 534, Type II for sheet materials, and with NFPA 90A or NFPA 90B.
 - 1. Maximum Thermal Conductivity: 0.25 Btu x in./h x sq. ft. x deg F at 75 deg F mean temperature.

2.5 SHEET METAL MATERIALS

- A. General Material Requirements: Comply with SMACNA's "HVAC Duct Construction Standards - Metal and Flexible" for acceptable materials, material thicknesses, and duct construction methods unless otherwise indicated. Sheet metal materials shall be free of pitting, seam marks, roller marks, stains, discolorations, and other imperfections.

- B. Galvanized Sheet Steel: Comply with ASTM A 653/A 653M.
 - 1. Galvanized Coating Designation: G90.
 - 2. Finishes for Surfaces Exposed to View: Mill phosphatized.

- C. PVC-Coated, Galvanized Sheet Steel: Comply with ASTM A 653/A 653M.
 - 1. Galvanized Coating Designation: G90.
 - 2. Minimum Thickness for Factory-Applied PVC Coating: 8 mils thick on sheet metal surface of ducts and fittings exposed to corrosive conditions, and minimum 3 mil thick on opposite surface.
 - 3. Coating Materials: Acceptable to authorities having jurisdiction for use on ducts listed and labeled by an NRTL for compliance with UL 181, Class 1.

- D. Carbon-Steel Sheets: Comply with ASTM A 1008/A 1008M, with oiled, matte finish for exposed ducts.
- E. Stainless-Steel Sheets: Comply with ASTM A 480/A 480M, Type 304 or 316, as indicated in the "Duct Schedule" Article; cold rolled, annealed, sheet. Exposed surface finish shall be No. 2B, No. 2D, No. 3, or No. 4 as indicated in the "Duct Schedule" Article.
- F. Factory- or Shop-Applied Antimicrobial Coating:
 - 1. Apply to the surface of sheet metal that will form the interior surface of the duct. An untreated clear coating shall be applied to the exterior surface.
 - 2. Antimicrobial compound shall be tested for efficacy by an NRTL and registered by the EPA for use in HVAC systems.
 - 3. Coating containing the antimicrobial compound shall have a hardness of 2H, minimum, when tested according to ASTM D 3363.
 - 4. Surface-Burning Characteristics: Maximum flame-spread index of 25 and maximum smoke-developed index of 50 when tested according to UL 723; certified by an NRTL.
 - 5. Shop-Applied Coating Color: Black.
 - 6. Antimicrobial coating on sheet metal is not required for duct containing liner treated with antimicrobial coating.
- G. Reinforcement Shapes and Plates: ASTM A 36/A 36M, steel plates, shapes, and bars; black and galvanized.
 - 1. Where black- and galvanized-steel shapes and plates are used to reinforce aluminum ducts, isolate the different metals with butyl rubber, neoprene, or EPDM gasket materials.
- H. Tie Rods: Galvanized steel, 1/4-inch minimum diameter for lengths 36 inches or less; 3/8-inch minimum diameter for lengths longer than 36 inches.

2.6 DUCT LINER

- A. Flexible Elastomeric Duct Liner: Preformed, cellular, closed-cell, sheet materials complying with ASTM C 534, Type II, Grade 1; and with NFPA 90A or NFPA 90B.
 - 1. Basis-of-Design Product: Subject to compliance with requirements, provide product indicated on Drawings or comparable product by one of the following:
 - a. Aeroflex USA Inc.
 - b. Armacell LLC.
 - c. Rubatex International, LLC
 - 2. Surface-Burning Characteristics: Maximum flame-spread index of 25 and maximum smoke-developed index of 50 when tested according to UL 723; certified by an NRTL.
 - 3. Liner Adhesive: As recommended by insulation manufacturer and complying with NFPA 90A or NFPA 90B.
 - a. Provide VOC certification of compliance to UL Greenguard Gold.
 - 1) Total VOC emission rate of 220 ug/m³. Manufacturer with UL 2818.

a) BOD: Sealants - Hardcast

- B. Natural-Fiber Duct Liner: 85 percent cotton, 10 percent borate, and 5 percent polybinding fibers, treated with a microbial growth inhibitor and complying with NFPA 90A or NFPA 90B.
1. Basis-of-Design Product: Subject to compliance with requirements, provide product indicated on Drawings or comparable product by one of the following:
 - a. Bonded Logic, Inc.
 - b. Reflectix Inc.
 2. Maximum Thermal Conductivity: 0.24 Btu x in./h x sq. ft. x deg F at 75 deg F mean temperature when tested according to ASTM C 518.
 3. Surface-Burning Characteristics: Maximum flame-spread index of 25 and maximum smoke-developed index of 50 when tested according to ASTM E 84; certified by an NRTL.
 4. Liner Adhesive: As recommended by insulation manufacturer and complying with NFPA 90A or NFPA 90B.
 - a. For indoor applications, use adhesive that has a VOC content of 50 g/L or less when calculated according to 40 CFR 59, Subpart D (EPA Method 24).
- C. Insulation Pins and Washers:
1. Cupped-Head, Capacitor-Discharge-Weld Pins: Copper- or zinc-coated steel pin, fully annealed for capacitor-discharge welding, 0.135-inch- diameter shank, length to suit depth of insulation indicated with integral 1-1/2-inch galvanized carbon-steel washer.
 2. Insulation-Retaining Washers: Self-locking washers formed from 0.016-inch- thick galvanized steel; with beveled edge sized as required to hold insulation securely in place but not less than 1-1/2 inches in diameter.
- D. Shop Application of Duct Liner: Comply with SMACNA's "HVAC Duct Construction Standards - Metal and Flexible," Figure 2-19, "Flexible Duct Liner Installation."
1. Adhere a single layer of indicated thickness of duct liner with at least 90 percent adhesive coverage at liner contact surface area. Attaining indicated thickness with multiple layers of duct liner is prohibited.
 2. Apply adhesive to transverse edges of liner facing upstream that do not receive metal nosing.
 3. Butt transverse joints without gaps, and coat joint with adhesive.
 4. Fold and compress liner in corners of rectangular ducts or cut and fit to ensure butted-edge overlapping.
 5. Do not apply liner in rectangular ducts with longitudinal joints, except at corners of ducts, unless duct size and dimensions of standard liner make longitudinal joints necessary.
 6. Apply adhesive coating on longitudinal seams in ducts with air velocity of 2500 fpm.
 7. Secure liner with mechanical fasteners 4 inches from corners and at intervals not exceeding 12 inches transversely; at 3 inches from transverse joints and at intervals not exceeding 18 inches longitudinally.
 8. Secure transversely oriented liner edges facing the airstream with metal nosings that have either channel or "Z" profiles or are integrally formed from duct wall. Fabricate edge facings at the following locations:

- a. Fan discharges.
 - b. Intervals of lined duct preceding unlined duct.
 - c. Upstream edges of transverse joints in ducts where air velocities are higher than 2500 fpm or where indicated.
9. Secure insulation between perforated sheet metal inner duct of same thickness as specified for outer shell. Use mechanical fasteners that maintain inner duct at uniform distance from outer shell without compressing insulation.
- a. Sheet Metal Inner Duct Perforations: 3/32-inch diameter, with an overall open area of 23 percent.
10. Terminate inner ducts with buildouts attached to fire-damper sleeves, dampers, turning vane assemblies, or other devices. Fabricated buildouts (metal hat sections) or other buildout means are optional; when used, secure buildouts to duct walls with bolts, screws, rivets, or welds.

2.7 SEALANT AND GASKETS

- A. General Sealant and Gasket Requirements: Surface-burning characteristics for sealants and gaskets shall be a maximum flame-spread index of 25 and a maximum smoke-developed index of 50 when tested according to UL 723; certified by an NRTL.
- B. Two-Part Tape Sealing System:
1. Tape: Woven cotton fiber impregnated with mineral gypsum and modified acrylic/silicone activator to react exothermically with tape to form hard, durable, airtight seal.
 2. Tape Width: 4 inches.
 3. Sealant: Modified styrene acrylic.
 4. Water resistant.
 5. Mold and mildew resistant.
 6. Maximum Static-Pressure Class: 10-inch wg, positive and negative.
 7. Service: Indoor and outdoor.
 8. Service Temperature: Minus 40 to plus 200 deg F.
 9. Substrate: Compatible with galvanized sheet steel (both PVC coated and bare), stainless steel, or aluminum.
 10. For indoor applications, use sealant that has a VOC content of 250 g/L or less when calculated according to 40 CFR 59, Subpart D (EPA Method 24).
- C. Water-Based Joint and Seam Sealant:
1. Application Method: Brush on.
 2. Solids Content: Minimum 65 percent.
 3. Shore A Hardness: Minimum 20.
 4. Water resistant.
 5. Mold and mildew resistant.
 6. VOC: Maximum 75 g/L (less water).
 7. Maximum Static-Pressure Class: 10-inch wg, positive and negative.

8. Service: Indoor or outdoor.
9. Substrate: Compatible with galvanized sheet steel (both PVC coated and bare), stainless steel, or aluminum sheets.

D. Solvent-Based Joint and Seam Sealant:

1. Application Method: Brush on.
2. Base: Synthetic rubber resin.
3. Solvent: Toluene and heptane.
4. Solids Content: Minimum 60 percent.
5. Shore A Hardness: Minimum 60.
6. Water resistant.
7. Mold and mildew resistant.
8. For indoor applications, use sealant that has a VOC content of 250 g/L or less when calculated according to 40 CFR 59, Subpart D (EPA Method 24).
9. VOC: Maximum 395 g/L.
10. Maximum Static-Pressure Class: 10-inch wg, positive or negative.
11. Service: Indoor or outdoor.
12. Substrate: Compatible with galvanized sheet steel (both PVC coated and bare), stainless steel, or aluminum sheets.

E. Flanged Joint Sealant: Comply with ASTM C 920.

1. General: Single-component, acid-curing, silicone, elastomeric.
2. Type: S.
3. Grade: NS.
4. Class: 25.
5. Use: O.
6. For indoor applications, use sealant that has a VOC content of 250 g/L or less when calculated according to 40 CFR 59, Subpart D (EPA Method 24).

F. Flange Gaskets: Butyl rubber, neoprene, or EPDM polymer with polyisobutylene plasticizer.

G. Round Duct Joint O-Ring Seals:

1. Seal shall provide maximum leakage class of 3 cfm/100 sq. ft. at 1-inch wg and shall be rated for 10-inch wg static-pressure class, positive or negative.
2. EPDM O-ring to seal in concave bead in coupling or fitting spigot.
3. Double-lipped, EPDM O-ring seal, mechanically fastened to factory-fabricated couplings and fitting spigots.

2.8 HANGERS AND SUPPORTS

- A. Hanger Rods for Noncorrosive Environments: Cadmium-plated steel rods and nuts.
- B. Hanger Rods for Corrosive Environments: Electrogalvanized, all-thread rods or galvanized rods with threads painted with zinc-chromate primer after installation.

- C. Strap and Rod Sizes: Comply with SMACNA's "HVAC Duct Construction Standards - Metal and Flexible," Table 4-1, "Rectangular Duct Hangers Minimum Size," and Table 4-2, "Minimum Hanger Sizes for Round Duct."
- D. Steel Cables for Galvanized-Steel Ducts: Galvanized steel complying with ASTM A 603.
- E. Steel Cables for Stainless-Steel Ducts: Stainless steel complying with ASTM A 492.
- F. Steel Cable End Connections: Cadmium-plated steel assemblies with brackets, swivel, and bolts designed for duct hanger service; with an automatic-locking and clamping device.
- G. Duct Attachments: Sheet metal screws, blind rivets, or self-tapping metal screws; compatible with duct materials.
- H. Trapeze and Riser Supports:
 - 1. Supports for Galvanized-Steel Ducts: Galvanized-steel shapes and plates.
 - 2. Supports for Stainless-Steel Ducts: Stainless-steel shapes and plates.
 - 3. Supports for Aluminum Ducts: Aluminum or galvanized steel coated with zinc chromate.

PART 3 - EXECUTION

3.1 DUCT INSTALLATION

- A. Drawing plans, schematics, and diagrams indicate general location and arrangement of duct system. Indicated duct locations, configurations, and arrangements were used to size ducts and calculate friction loss for air-handling equipment sizing and for other design considerations. Install duct systems as indicated unless deviations to layout are approved on Shop Drawings and Coordination Drawings.
- B. Install ducts according to SMACNA's "HVAC Duct Construction Standards - Metal and Flexible" unless otherwise indicated.
- C. Install round ducts in maximum practical lengths.
- D. Install ducts with fewest possible joints.
- E. Install factory- or shop-fabricated fittings for changes in direction, size, and shape and for branch connections.
- F. Unless otherwise indicated, install ducts vertically and horizontally, and parallel and perpendicular to building lines.
- G. Install ducts close to walls, overhead construction, columns, and other structural and permanent enclosure elements of building.
- H. Install ducts with a clearance of 1 inch, plus allowance for insulation thickness.

- I. Route ducts to avoid passing through transformer vaults and electrical equipment rooms and enclosures.
- J. Where ducts pass through non-fire-rated interior partitions and exterior walls and are exposed to view, cover the opening between the partition and duct or duct insulation with sheet metal flanges of same metal thickness as the duct. Overlap openings on four sides by at least 1-1/2 inches.
- K. Where ducts pass through fire-rated interior partitions and exterior walls, install fire dampers. Comply with requirements in Division 23 Section "Air Duct Accessories" for fire and smoke dampers.
- L. Protect duct interiors from moisture, construction debris and dust, and other foreign materials. Comply with SMACNA's "Duct Cleanliness for New Construction Guidelines."

3.2 INSTALLATION OF EXPOSED DUCTWORK

- A. Protect ducts exposed in finished spaces from being dented, scratched, or damaged.
- B. Trim duct sealants flush with metal. Create a smooth and uniform exposed bead. Do not use two-part tape sealing system.
- C. Grind welds to provide smooth surface free of burrs, sharp edges, and weld splatter. When welding stainless steel with a No. 3 or 4 finish, grind the welds flush, polish the exposed welds, and treat the welds to remove discoloration caused by welding.
- D. Maintain consistency, symmetry, and uniformity in the arrangement and fabrication of fittings, hangers and supports, duct accessories, and air outlets.
- E. Repair or replace damaged sections and finished work that does not comply with these requirements.

3.3 DUCT SEALING

- A. Seal ducts for duct static-pressure, seal classes, and leakage classes specified in "Duct Schedule" Article according to SMACNA's "HVAC Duct Construction Standards - Metal and Flexible."
- B. Seal ducts to the following seal classes according to SMACNA's "HVAC Duct Construction Standards - Metal and Flexible":
 - 1. Comply with SMACNA's "HVAC Duct Construction Standards - Metal and Flexible."
 - 2. Outdoor, Supply-Air Ducts: Seal Class A.
 - 3. Outdoor, Exhaust Ducts: Seal Class C.
 - 4. Outdoor, Return-Air Ducts: Seal Class C.
 - 5. Unconditioned Space, Supply-Air Ducts in Pressure Classes 2-Inch wg and Lower: Seal Class B.

6. Unconditioned Space, Supply-Air Ducts in Pressure Classes Higher Than 2-Inch wg: Seal Class A.
7. Unconditioned Space, Exhaust Ducts: Seal Class C.
8. Unconditioned Space, Return-Air Ducts: Seal Class B.
9. Conditioned Space, Supply-Air Ducts in Pressure Classes 2-Inch wg and Lower: Seal Class C.
10. Conditioned Space, Supply-Air Ducts in Pressure Classes Higher Than 2-Inch wg: Seal Class B.
11. Conditioned Space, Exhaust Ducts: Seal Class B.
12. Conditioned Space, Return-Air Ducts: Seal Class C.

3.4 HANGER AND SUPPORT INSTALLATION

- A. Comply with SMACNA's "HVAC Duct Construction Standards - Metal and Flexible," Chapter 4, "Hangers and Supports."
- B. Building Attachments: Concrete inserts, powder-actuated fasteners, or structural-steel fasteners appropriate for construction materials to which hangers are being attached.
 1. Where practical, install concrete inserts before placing concrete.
 2. Install powder-actuated concrete fasteners after concrete is placed and completely cured.
 3. Use powder-actuated concrete fasteners for standard-weight aggregate concretes or for slabs more than 4 inches thick.
 4. Do not use powder-actuated concrete fasteners for lightweight-aggregate concretes or for slabs less than 4 inches thick.
 5. Do not use powder-actuated concrete fasteners for seismic restraints.
- C. Hanger Spacing: Comply with SMACNA's "HVAC Duct Construction Standards - Metal and Flexible," Table 4-1 (Table 4-1M), "Rectangular Duct Hangers Minimum Size," and Table 4-2, "Minimum Hanger Sizes for Round Duct," for maximum hanger spacing; install hangers and supports within 24 inches of each elbow and within 48 inches of each branch intersection.
- D. Hangers Exposed to View: Threaded rod and angle or channel supports.
- E. Support vertical ducts with steel angles or channel secured to the sides of the duct with welds, bolts, sheet metal screws, or blind rivets; support at each floor and at a maximum intervals of 16 feet.
- F. Install upper attachments to structures. Select and size upper attachments with pull-out, tension, and shear capacities appropriate for supported loads and building materials where used.

3.5 CONNECTIONS

- A. Make connections to equipment with flexible connectors complying with Division 23 Section "Air Duct Accessories."
- B. Comply with SMACNA's "HVAC Duct Construction Standards - Metal and Flexible" for branch, outlet and inlet, and terminal unit connections.

3.6 PAINTING

- A. Paint interior of metal ducts that are visible through registers and grilles and that do not have duct liner. Apply one coat of flat, black, latex paint over a compatible galvanized-steel primer. Paint materials and application requirements are specified in Division 09 painting Sections.

3.7 FIELD QUALITY CONTROL

- A. Perform tests and inspections.

- B. Leakage Tests:

1. Comply with SMACNA's "HVAC Air Duct Leakage Test Manual." Submit a test report for each test.
2. Test the following systems:
 - a. Ducts with a Pressure Class Higher Than 3-Inch wg: Test 100% duct sections duct for each designated pressure class.
 - b. Supply Ducts with a Pressure Class of 3-Inch wg or Higher: Test 100% duct sections duct for each designated pressure class.
 - c. Supply Duct with a Pressure Class of 2-Inch wg or Higher: Test 25% duct sections duct for each designated pressure class.
 - d. Return Ducts with a Pressure Class of 3-Inch wg or Higher: Test 100% duct sections duct for each designated pressure class.
 - e. Return Ducts with a Pressure Class of 2-inch wg or Higher: Test 25% duct sections duct for each designated pressure class.
 - f. Exhaust Ducts with a Pressure Class of 3-Inch wg or Higher: Test 100% duct sections duct for each designated pressure class.
 - g. Outdoor Air Ducts with a Pressure Class of 2-Inch wg or Higher: Test 100% duct sections duct for each designated pressure class.
3. If Supply or Return duct with Pressure class of 2-Inch wg or higher fails test than retest shall be 40% duct testing will be required.
4. Disassemble, reassemble, and seal segments of systems to accommodate leakage testing and for compliance with test requirements.
5. Test for leaks before applying external insulation.
6. Conduct tests at static pressures equal to maximum design pressure of system or section being tested. If static-pressure classes are not indicated, test system at maximum system design pressure. Do not pressurize systems above maximum design operating pressure.
7. Give seven days' advance notice for testing.
8. Failure of duct leakage test:
 - a. Inspect the Pressurized duct (and all connections between the flowmeter and the duct) for all sensible leaks. A smoke bomb test might be used to identify actual leak source, however approval will need to be from project PM.
 - b. If leak sites were not discovered, consider dividing the duct into smaller segments or use a larger apparatus.
 - c. Allow repaired seals to cure and retest until the leakage rate is acceptable.

- C. Duct System Cleanliness Tests:

1. Visually inspect duct system to ensure that no visible contaminants are present.
 2. Test sections of metal duct system, chosen randomly by Owner, for cleanliness according to "Vacuum Test" in NADCA ACR, "Assessment, Cleaning and Restoration of HVAC Systems."
 - a. Acceptable Cleanliness Level: Net weight of debris collected on the filter media shall not exceed 0.75 mg/100 sq. cm.
 - b. Provide and install access doors at locations where duct was cleaned for inspections and future cleaning. Access doors shall match or exceed the static pressure of duct. Provide double wall access doors if duct is double walled or internally lined.
- D. Duct system will be considered defective if it does not pass tests and inspections.
- E. Prepare test and inspection reports.

3.8 DUCT CLEANING

- A. Clean new and existing duct system(s) before testing, adjusting, and balancing.
- B. Use service openings for entry and inspection.
1. Create new openings and install access panels appropriate for duct static-pressure class if required for cleaning access. Provide insulated panels for insulated or lined duct. Patch insulation and liner as recommended by duct liner manufacturer. Comply with Division 23 Section "Air Duct Accessories" for access panels and doors.
 2. Disconnect and reconnect flexible ducts as needed for cleaning and inspection.
 3. Remove and reinstall ceiling to gain access during the cleaning process.
- C. Particulate Collection and Odor Control:
1. When venting vacuuming system inside the building, use HEPA filtration with 99.97 percent collection efficiency for 0.3-micron-size (or larger) particles.
 2. When venting vacuuming system to outdoors, use filter to collect debris removed from HVAC system, and locate exhaust downwind and away from air intakes and other points of entry into building.
- D. Clean the following components by removing surface contaminants and deposits:
1. Air outlets and inlets (registers, grilles, and diffusers).
 2. Supply, return, and exhaust fans including fan housings, plenums (except ceiling supply and return plenums), scrolls, blades or vanes, shafts, baffles, dampers, and drive assemblies.
 3. Air-handling unit internal surfaces and components including mixing box, coil section, air wash systems, spray eliminators, condensate drain pans, humidifiers and dehumidifiers, filters and filter sections, and condensate collectors and drains.
 4. Coils and related components.

5. Return-air ducts, dampers, actuators, and turning vanes except in ceiling plenums and mechanical equipment rooms.
6. Supply-air ducts, dampers, actuators, and turning vanes.
7. Dedicated exhaust and ventilation components and makeup air systems.

E. Mechanical Cleaning Methodology:

1. Clean metal duct systems using mechanical cleaning methods that extract contaminants from within duct systems and remove contaminants from building.
2. Use vacuum-collection devices that are operated continuously during cleaning. Connect vacuum device to downstream end of duct sections so areas being cleaned are under negative pressure.
3. Use mechanical agitation to dislodge debris adhered to interior duct surfaces without damaging integrity of metal ducts, duct liner, or duct accessories.
4. Clean fibrous-glass duct liner with HEPA vacuuming equipment; do not permit duct liner to get wet. Replace fibrous-glass duct liner that is damaged, deteriorated, or delaminated or that has friable material, mold, or fungus growth.
5. Clean coils and coil drain pans according to NADCA 1992. Keep drain pan operational. Rinse coils with clean water to remove latent residues and cleaning materials; comb and straighten fins.
6. Provide drainage and cleanup for wash-down procedures.
7. Antimicrobial Agents and Coatings: Apply EPA-registered antimicrobial agents if fungus is present. Apply antimicrobial agents according to manufacturer's written instructions after removal of surface deposits and debris.

3.9 START UP

- A. Air Balance: Comply with requirements in Division 23 Section "Testing, Adjusting, and Balancing for HVAC."

3.10 DUCT SCHEDULE

A. Supply Ducts:

1. Ducts Connected to Fan Coil Units, Furnaces, Heat Pumps, and Terminal Units:
 - a. Pressure Class: Positive 2-inch wg.
 - b. Minimum SMACNA Seal Class: C.
 - c. SMACNA Leakage Class for Rectangular: 12.
 - d. SMACNA Leakage Class for Round and Flat Oval: 12.
2. Ducts Connected to Constant-Volume Air-Handling Units:
 - a. Pressure Class: Positive 3-inch wg.
 - b. Minimum SMACNA Seal Class: B.
 - c. SMACNA Leakage Class for Rectangular: 6.
 - d. SMACNA Leakage Class for Round and Flat Oval: 6.

3. Ducts Connected to Variable-Air-Volume Air-Handling Units:
 - a. Pressure Class: Positive 3-inch wg.
 - b. Minimum SMACNA Seal Class: B.
 - c. SMACNA Leakage Class for Rectangular: 6.
 - d. SMACNA Leakage Class for Round and Flat Oval: 6.
 4. Ducts Connected to Equipment Not Listed Above:
 - a. Pressure Class: Positive 3-inch wg.
 - b. Minimum SMACNA Seal Class: B.
 - c. SMACNA Leakage Class for Rectangular: 6
 - d. SMACNA Leakage Class for Round and Flat Oval: 6.
- B. Return Ducts:
1. Ducts Connected to Fan Coil Units, Furnaces, Heat Pumps, and Terminal Units:
 - a. Pressure Class: Positive or negative 2-inch wg.
 - b. Minimum SMACNA Seal Class: C.
 - c. SMACNA Leakage Class for Rectangular: 12.
 - d. SMACNA Leakage Class for Round and Flat Oval: 12.
 2. Ducts Connected to Air-Handling Units:
 - a. Pressure Class: Positive or negative 3-inch wg.
 - b. Minimum SMACNA Seal Class: A B.
 - c. SMACNA Leakage Class for Rectangular: 6.
 - d. SMACNA Leakage Class for Round and Flat Oval: 6.
 3. Ducts Connected to Equipment Not Listed Above:
 - a. Pressure Class: Positive or negative 3-inch wg.
 - b. Minimum SMACNA Seal Class: B.
 - c. SMACNA Leakage Class for Rectangular: 6.
 - d. SMACNA Leakage Class for Round and Flat Oval: 6.
- C. Exhaust Ducts:
1. Ducts Connected to Fans Exhausting (ASHRAE 62.1, Class 1 and 2) Air:
 - a. Pressure Class: Negative 2-inch wg.
 - b. Minimum SMACNA Seal Class: B if negative pressure, and A if positive pressure.
 - c. SMACNA Leakage Class for Rectangular: 12.
 - d. SMACNA Leakage Class for Round and Flat Oval: 12.
 2. Ducts Connected to Air-Handling Units:
 - a. Pressure Class: Positive or negative 2-inch wg.

- b. Minimum SMACNA Seal Class: B if negative pressure, and A if positive pressure.
 - c. SMACNA Leakage Class for Rectangular: 12.
 - d. SMACNA Leakage Class for Round and Flat Oval: 12.
3. Ducts Connected to Fans Exhausting Laboratory and Process (ASHRAE 62.1, Class 3 and 4) Air:
- a. Type 304, stainless-steel welded sheet.
 - 1) Exposed to View: No. 4 finish.
 - 2) Concealed: No. 2B finish.
 - b. PVC-coated, galvanized sheet steel with thicker coating on duct interior.
 - c. Pressure Class: Positive or negative 4-inch wg.
 - d. Minimum SMACNA Seal Class: Welded seams, joints, and penetrations.
 - e. SMACNA Leakage Class: 3.
 - f. In addition to locations shown on drawings; install at fume hood exhaust and connection and entire branches from fume hood to exhaust main.
4. Ducts Connected to Equipment Not Listed Above:
- a. Pressure Class: Positive or negative 4-inch wg.
 - b. Minimum SMACNA Seal Class: B if negative pressure, and A if positive pressure.
 - c. SMACNA Leakage Class for Rectangular: 12.
 - d. SMACNA Leakage Class for Round and Flat Oval: 12.
- D. Outdoor-Air (Not Filtered, Heated, or Cooled) Ducts:
1. Ducts Connected to Fan Coil Units, Furnaces, Heat Pumps, and Terminal Units:
- a. Pressure Class: Positive or negative 2-inch wg.
 - b. Minimum SMACNA Seal Class: C.
 - c. SMACNA Leakage Class for Rectangular: 12.
 - d. SMACNA Leakage Class for Round and Flat Oval: 12.
2. Ducts Connected to Air-Handling Units:
- a. Pressure Class: Positive or negative 3-inch wg.
 - b. Minimum SMACNA Seal Class: B.
 - c. SMACNA Leakage Class for Rectangular: 12.
 - d. SMACNA Leakage Class for Round and Flat Oval: 12.
3. Ducts Connected to Equipment Not Listed Above:
- a. Pressure Class: Positive or negative 3-inch wg.
 - b. Minimum SMACNA Seal Class: B.
 - c. SMACNA Leakage Class for Rectangular: 12.
 - d. SMACNA Leakage Class for Round and Flat Oval: 12.

E. Intermediate Reinforcement:

1. Galvanized-Steel Ducts: Galvanized steel or carbon steel coated with zinc-chromate primer.
2. PVC-Coated Ducts:
 - a. Exposed to Airstream: Match duct material.
 - b. Not Exposed to Airstream: Match duct material.
3. Stainless-Steel Ducts:
 - a. Exposed to Airstream: Match duct material.
 - b. Not Exposed to Airstream: Match duct material.

F. Liner:

1. Supply Air Ducts: 1-1/2 inches thick.
2. Return Air Ducts: 1-1/2 inches thick.
3. Exhaust Air Ducts: 1 inch.
4. Supply Fan Plenums: 2 inches thick.
5. Return- and Exhaust-Fan Plenums: 2 inches thick.
6. Transfer Ducts: 1 inch thick.

G. Double-Wall Duct Interstitial Insulation:

1. Supply Air Ducts: 1-1/2 inches thick.
2. Return Air Ducts: 1-1/2 inches thick.
3. Exhaust Air Ducts: 1 inch thick.

H. Elbow Configuration:

1. Rectangular Duct: Comply with SMACNA's "HVAC Duct Construction Standards - Metal and Flexible," Figure 2-2, "Rectangular Elbows."
 - a. Velocity 1000 fpm or Lower:
 - 1) Radius Type RE 1 with minimum 0.5 radius-to-diameter ratio.
 - 2) Mitered Type RE 4 without vanes.
 - b. Velocity 1000 to 1500 fpm:
 - 1) Radius Type RE 1 with minimum 1.0 radius-to-diameter ratio.
 - 2) Radius Type RE 3 with minimum 0.5 radius-to-diameter ratio and two vanes.
 - 3) Mitered Type RE 2 with vanes complying with SMACNA's "HVAC Duct Construction Standards - Metal and Flexible," Figure 2-3, "Vanes and Vane Runners," and Figure 2-4, "Vane Support in Elbows."
 - c. Velocity 1500 fpm or Higher:

- 1) Radius Type RE 1 with minimum 1.5 radius-to-diameter ratio.
 - 2) Radius Type RE 3 with minimum 1.0 radius-to-diameter ratio and two vanes.
 - 3) Mitered Type RE 2 with vanes complying with SMACNA's "HVAC Duct Construction Standards - Metal and Flexible," Figure 2-3, "Vanes and Vane Runners," and Figure 2-4, "Vane Support in Elbows."
2. Rectangular Duct: Comply with SMACNA's "HVAC Duct Construction Standards - Metal and Flexible," Figure 2-2, "Rectangular Elbows."
 - a. Radius Type RE 1 with minimum 1.5 radius-to-diameter ratio.
 - b. Radius Type RE 3 with minimum 1.0 radius-to-diameter ratio and two vanes.
 - c. Mitered Type RE 2 with vanes complying with SMACNA's "HVAC Duct Construction Standards - Metal and Flexible," Figure 2-3, "Vanes and Vane Runners," and Figure 2-4, "Vane Support in Elbows."
 3. Round Duct: Comply with SMACNA's "HVAC Duct Construction Standards - Metal and Flexible," Figure 3-3, "Round Duct Elbows."
 - a. Minimum Radius-to-Diameter Ratio and Elbow Segments: Comply with SMACNA's "HVAC Duct Construction Standards - Metal and Flexible," Table 3-1, "Mitered Elbows." Elbows with less than 90-degree change of direction have proportionately fewer segments.
 - 1) Velocity 1000 fpm or Lower: 0.5 radius-to-diameter ratio and three segments for 90-degree elbow.
 - 2) Velocity 1000 to 1500 fpm: 1.0 radius-to-diameter ratio and four segments for 90-degree elbow.
 - 3) Velocity 1500 fpm or Higher: 1.5 radius-to-diameter ratio and five segments for 90-degree elbow.
 - 4) Radius-to Diameter Ratio: 1.5.
 - b. Round Elbows, 12 Inches and Smaller in Diameter: Stamped or pleated.
 - c. Round Elbows, 14 Inches and Larger in Diameter: Welded.
- I. Branch Configuration:
1. Rectangular Duct: Comply with SMACNA's "HVAC Duct Construction Standards - Metal and Flexible," Figure 2-6, "Branch Connections."
 - a. Rectangular Main to Rectangular Branch: 45-degree entry.
 - b. Rectangular Main to Round Branch: Spin in.
 2. Round and Flat Oval: Comply with SMACNA's "HVAC Duct Construction Standards - Metal and Flexible," Figure 3-4, "90 Degree Tees and Laterals," and Figure 3-5, "Conical Tees." Saddle taps are permitted in existing duct.
 - a. Velocity 1000 fpm or Lower: 90-degree tap.
 - b. Velocity 1000 to 1500 fpm: Conical tap.
 - c. Velocity 1500 fpm or Higher: 45-degree lateral.

END OF SECTION 233113

SECTION 233300 - AIR DUCT ACCESSORIES

PART 1 - GENERAL

1.1 RELATED DOCUMENTS

- A. Drawings and general provisions of the Contract, including General and Supplementary Conditions and Division 01 Specification Sections, apply to this Section.

1.2 SUMMARY

- A. Section Includes:

1. Backdraft and pressure relief dampers.
2. Barometric relief dampers.
3. Manual volume dampers.
4. Control dampers.
5. Fire dampers.
6. Combination fire and smoke dampers.
7. Corridor dampers.
8. Flange connectors.
9. Duct silencers.
10. Turning vanes.
11. Remote damper operators.
12. Duct-mounted access doors.
13. Flexible connectors.
14. Flexible ducts.
15. Duct accessory hardware.
16. Test Ports

- B. Related Sections:

1. Division 23 Section "HVAC PowerVentilators" for roof-mounted ventilator caps.

1.3 SUBMITTALS

- A. Product Data: For each type of product indicated.

1. For duct silencers, include pressure drop and dynamic insertion loss data. Include breakout noise calculations for high transmission loss casings.

- B. Shop Drawings: For duct accessories. Include plans, elevations, sections, details and attachments to other work.

1. Detail duct accessories fabrication and installation in ducts and other construction. Include dimensions, weights, loads, and required clearances; and method of field assembly into duct systems and other construction. Include the following:
 - a. Special fittings.
 - b. Manual volume damper installations.
 - c. Control damper installations.
 - d. Fire-damper, smoke-damper, combination fire- and smoke-damper, ceiling, and corridor damper installations, including sleeves; and duct-mounted access doors and remote damper operators.
 - e. Duct security bars.
 - f. Wiring Diagrams: For power, signal, and control wiring.

- C. Coordination Drawings: Reflected ceiling plans, drawn to scale, on which ceiling-mounted access panels and access doors required for access to duct accessories are shown and coordinated with each other, using input from Installers of the items involved.
- D. Source quality-control reports.
- E. Operation and Maintenance Data: For air duct accessories to include in operation and maintenance manuals.

1.4 QUALITY ASSURANCE

- A. Comply with NFPA 90A, "Installation of Air Conditioning and Ventilating Systems," and with NFPA 90B, "Installation of Warm Air Heating and Air Conditioning Systems."
- B. Comply with AMCA 500-D testing for damper rating.

1.5 EXTRA MATERIALS

- A. Furnish extra materials that match products installed and that are packaged with protective covering for storage and identified with labels describing contents.
 1. Fusible Links: Furnish quantity equal to 10 percent of amount installed.

PART 2 - PRODUCTS

2.1 MATERIALS

- A. Comply with SMACNA's "HVAC Duct Construction Standards - Metal and Flexible" for acceptable materials, material thicknesses, and duct construction methods unless otherwise indicated. Sheet metal materials shall be free of pitting, seam marks, roller marks, stains, discolorations, and other imperfections.
- B. Galvanized Sheet Steel: Comply with ASTM A 653/A 653M.

1. Galvanized Coating Designation: G60.
 2. Exposed-Surface Finish: Mill phosphatized.
- C. Stainless-Steel Sheets: Comply with ASTM A 480/A 480M, Type 304, and having a No. 2 finish for concealed ducts and finish for exposed ducts.
- D. Aluminum Sheets: Comply with ASTM B 209, Alloy 3003, Temper H14; with mill finish for concealed ducts and standard, 1-side bright finish for exposed ducts.
- E. Extruded Aluminum: Comply with ASTM B 221, Alloy 6063, Temper T6.
- F. Reinforcement Shapes and Plates: Galvanized-steel reinforcement where installed on galvanized sheet metal ducts; compatible materials for aluminum and stainless-steel ducts.
- G. Tie Rods: Galvanized steel, 1/4-inch minimum diameter for lengths 36 inches or less; 3/8-inch minimum diameter for lengths longer than 36 inches.

2.2 BACKDRAFT AND PRESSURE RELIEF DAMPERS

- A. Manufacturers: Subject to compliance with requirements, provide products by one of the following:
1. Air Balance Inc.; a division of Mestek, Inc.
 2. Duro Dyne Inc.
 3. Greenheck Fan Corporation.
 4. Nailor Industries Inc.
 5. Ruskin Company.
 6. SEMCO Incorporated.
 7. Vent Products Company, Inc.
- B. Description: Gravity balanced.
- C. Maximum Air Velocity: 2000 fpm.
- D. Maximum System Pressure: 2-inch wg.
- E. Frame: 0.052-inch- thick, galvanized sheet steel.
- F. Blades: Multiple single-piece blades, center-pivoted, maximum 6-inch width, 0.025-inch-thick, roll-formed aluminum 0.050-inch- thick aluminum sheet with sealed edges.
- G. Blade Action: Parallel.
- H. Blade Seals: Felt or Neoprene, mechanically locked.
- I. Blade Axles:
1. Material: Galvanized steel.
 2. Diameter: 0.20 inch.

- J. Tie Bars and Brackets: Galvanized steel.
- K. Return Spring: Adjustable tension.
- L. Bearings: Steel ball or synthetic pivot bushings.
- M. Accessories:
 - 1. Adjustment device to permit setting for varying differential static pressure.
 - 2. Counterweights and spring-assist kits for vertical airflow installations.
 - 3. Electric actuators.
 - 4. Chain pulls.
 - 5. Screen Mounting: Front mounted in sleeve.
 - a. Sleeve Thickness: 20-gage minimum.
 - b. Sleeve Length: 6 inches minimum.
 - 6. Screen Mounting: Rear mounted.
 - 7. Screen Material: Galvanized steel.
 - 8. Screen Type: Bird.
 - 9. 90-degree stops.

2.3 BAROMETRIC RELIEF DAMPERS

- A. Manufacturers: Subject to compliance with requirements, provide products by one of the following:
 - 1. Air Balance Inc.; a division of Mestek, Inc.
 - 2. Duro Dyne Inc.
 - 3. Greenheck Fan Corporation.
 - 4. Nailor Industries Inc.
 - 5. Ruskin Company.
 - 6. SEMCO Incorporated.
 - 7. Vent Products Company, Inc.
- B. Suitable for horizontal or vertical mounting.
- C. Maximum Air Velocity: 2000 fpm.
- D. Maximum System Pressure: 2-inch wg.
- E. Frame: 0.064 inch thick (16 GA), galvanized sheet steel.
- F. Blades:
 - 1. Multiple, 0.025-inch- thick, roll-formed aluminum.
 - 2. Maximum Width: 6 inches.
 - 3. Action: Parallel.
 - 4. Balance: Gravity.

- 5. Eccentrically pivoted.
- G. Blade Seals: Neoprene.
- H. Blade Axles: Galvanized steel.
- I. Tie Bars and Brackets:
 - 1. Material: Galvanized steel.
 - 2. Rattle free with 90-degree stop.
- J. Return Spring: Adjustable tension.
- K. Bearings: Bronze.
- L. Accessories:
 - 1. Flange on intake.
 - 2. Adjustment device to permit setting for varying differential static pressures.

2.4 MANUAL VOLUME DAMPERS

- A. Standard, Steel, Manual Volume Dampers:
 - 1. Manufacturers: Subject to compliance with requirements, provide products by one of the following:
 - a. Air Balance Inc.; a division of Mestek, Inc.
 - b. Flexmaster U.S.A., Inc.
 - c. McGill AirFlow LLC.
 - d. METALAIRE, Inc.
 - e. Nailor Industries Inc.
 - f. Ruskin Company.
 - g. Vent Products Company, Inc.
 - 2. Standard leakage rating, with linkage outside airstream.
 - 3. Suitable for horizontal or vertical applications.
 - 4. Frames:
 - a. Hat-shaped, galvanized-steel channels, 0.064-inch minimum thickness.
 - b. Mitered and welded corners.
 - c. Flanges for attaching to walls and flangeless frames for installing in ducts.
 - 5. Blades:
 - a. Multiple or single blade.
 - b. Parallel- or opposed-blade design.
 - c. Stiffen damper blades for stability.
 - d. Galvanized-steel, 0.064 inch thick (16 GA).

6. Blade Axles: Galvanized steel.
 7. Bearings:
 - a. Oil-impregnated bronze.
 - b. Dampers in ducts with pressure classes of 3-inch wg or less shall have axles full length of damper blades and bearings at both ends of operating shaft.
 8. Tie Bars and Brackets: Galvanized steel.
- B. Low-Leakage, Steel, Manual Volume Dampers:
1. Manufacturers: Subject to compliance with requirements, provide products by one of the following:
 - a. Air Balance Inc.; a division of Mestek, Inc.
 - b. Flexmaster U.S.A., Inc.
 - c. McGill AirFlow LLC.
 - d. METALAIRE, Inc.
 - e. Nailor Industries Inc.
 - f. Ruskin Company.
 - g. Vent Products Company, Inc.
 2. Low-leakage rating, with linkage outside airstream, and bearing AMCA's Certified Ratings Seal for both air performance and air leakage.
 3. Suitable for horizontal or vertical applications.
 4. Frames:
 - a. Hat shaped.
 - b. Galvanized-steel channels, 0.064 inch thick.
 - c. Mitered and welded corners.
 - d. Flanges for attaching to walls and flangeless frames for installing in ducts.
 5. Blades:
 - a. Multiple or single blade.
 - b. Parallel- or opposed-blade design.
 - c. Stiffen damper blades for stability.
 - d. Galvanized, roll-formed steel, 0.064 inch thick (16 GA).
 6. Blade Axles: Galvanized steel.
 7. Bearings:
 - a. Oil-impregnated bronze.
 - b. Dampers in ducts with pressure classes of 3-inch wg or less shall have axles full length of damper blades and bearings at both ends of operating shaft.
 8. Blade Seals: Felt or Neoprene.
 9. Jamb Seals: Cambered stainless steel.
 10. Tie Bars and Brackets: Galvanized steel.
 11. Accessories:

- a. Include locking device to hold single-blade dampers in a fixed position without vibration.

2.5 CONTROL DAMPERS

- A. Manufacturers: Subject to compliance with requirements, provide products by one of the following:
 1. Arrow United Industries; a division of Mestek, Inc.
 2. Cesco Products; a division of Mestek, Inc.
 3. Duro Dyne Inc.
 4. Flexmaster U.S.A., Inc.
 5. Greenheck Fan Corporation.
 6. McGill AirFlow LLC.
 7. METALAIRE, Inc.
 8. Nailor Industries Inc.
 9. Ruskin Company.
 10. Vent Products Company, Inc.
 11. Young Regulator Company.
- B. Low-leakage rating, with linkage outside airstream, and bearing AMCA's Certified Ratings Seal for both air performance and air leakage.
- C. Frames:
 1. Hat shaped.
 2. Galvanized-steel channels, 0.064 inch thick (16 GA).
 3. Mitered and welded corners.
- D. Blades:
 1. Multiple blade with maximum blade width of 8 inches.
 2. Opposed-blade design.
 3. Galvanizedsteel.
 4. 0.064 inch thick (16 GA).
 5. Blade Edging: Closed-cell neoprene edging.
 6. Blade Edging: Inflatable seal blade edging, or replaceable rubber seals.
- E. Blade Axles: 1/2-inch-diameter; galvanized steel; blade-linkage hardware of zinc-plated steel and brass; ends sealed against blade bearings.
 1. Operating Temperature Range: From minus 40 to plus 200 deg F.
- F. Bearings:
 1. Oil-impregnated bronze.
 2. Dampers in ducts with pressure classes of 3-inch wg or less shall have axles full length of damper blades and bearings at both ends of operating shaft.
 3. Thrust bearings at each end of every blade.

2.6 FIRE DAMPERS

- A. Manufacturers: Subject to compliance with requirements, provide products by one of the following:
1. Air Balance Inc.; a division of Mestek, Inc.
 2. Arrow United Industries; a division of Mestek, Inc.
 3. Greenheck Fan Corporation.
 4. McGill AirFlow LLC.
 5. METALAIRE, Inc.
 6. Nailor Industries Inc.
 7. Ruskin Company.
 8. Vent Products Company, Inc.
 9. Ward Industries, Inc.; a division of Hart & Cooley, Inc.
- B. Type: Static and dynamic; rated and labeled according to UL 555 by an NRTL.
- C. Closing rating in ducts up to 4-inch wg static pressure class and minimum 4000-fpm velocity.
- D. Fire Rating: 1-1/2 and 3 hours.
- E. Frame: Curtain type with blades outside airstream except when located behind grille where blades may be inside airstream; fabricated with roll-formed, 0.034-inch-thick galvanized steel; with mitered and interlocking corners.
- F. Mounting Sleeve: Factory- or field-installed, galvanized sheet steel.
1. Minimum Thickness: 0.052 or 0.138 inch thick, as indicated, and of length to suit application.
 2. Exception: Omit sleeve where damper-frame width permits direct attachment of perimeter mounting angles on each side of wall or floor; thickness of damper frame must comply with sleeve requirements.
- G. Mounting Orientation: Vertical or horizontal as indicated.
- H. Blades: Roll-formed, interlocking, 0.034-inch-thick, galvanized sheet steel. In place of interlocking blades, use full-length, 0.034-inch-thick, galvanized-steel blade connectors.
- I. Horizontal Dampers: Include blade lock and stainless-steel closure spring.
- J. Heat-Responsive Device: Replaceable, 165 deg F rated, fusible links.
- K. Heat-Responsive Device: Electric resettable link and switch package, factory installed, 165 deg F rated.

2.7 COMBINATION FIRE AND SMOKE DAMPERS

- A. Manufacturers: Subject to compliance with requirements, provide products by one of the following:

1. Air Balance Inc.; a division of Mestek, Inc.
 2. Cesco Products; a division of Mestek, Inc.
 3. Greenheck Fan Corporation.
 4. Nailor Industries Inc.
 5. Ruskin Company.
- B. Type: Static and dynamic; rated and labeled according to UL 555 and UL 555S by an NRTL.
- C. Closing rating in ducts up to 4-inch wg static pressure class and minimum 4000-fpm velocity.
- D. Fire Rating: 1-1/2 and 3 hours.
- E. Frame: Curtain type with blades outside airstream except when located behind grille where blades may be inside airstream; fabricated with roll-formed, 0.034-inch-thick galvanized steel; with mitered and interlocking corners.
- F. Heat-Responsive Device: Replaceable, 165 deg F rated, fusible links.
- G. Heat-Responsive Device: Electric resettable link and switch package, factory installed, rated.
- H. Smoke Detector: Integral, factory wired for single-point connection.
- I. Frame: Curtain type with blades outside airstream except when located behind grille where blades may be inside airstream; fabricated with roll-formed, 0.034-inch thick galvanized steel; with mitered and interlocking corners.
- J. Blades: Roll-formed, horizontal, interlocking, 0.034-inch-thick, galvanized sheet steel. In place of interlocking blades, use full-length, 0.034-inch-thick, galvanized-steel blade connectors.
- K. Leakage: Class II.
- L. Rated pressure and velocity to exceed design airflow conditions.
- M. Mounting Sleeve: Factory-installed, 0.052-inch-thick, galvanized sheet steel; length to suit wall or floor application with factory-furnished silicone caulking.
- N. Master control panel for use in dynamic smoke-management systems.
- O. Damper Motors: Modulating or two-position action.
- P. Comply with NEMA designation, temperature rating, service factor, enclosure type, and efficiency requirements for motors specified in Division 23 Section "Common Motor Requirements for HVAC Equipment."
1. Motor Sizes: Minimum size as indicated. If not indicated, large enough so driven load will not require motor to operate in service factor range above 1.0.
 2. Controllers, Electrical Devices, and Wiring: Comply with requirements for electrical devices and connections specified in Division 23 Section "Direct Digital Control (DDC) for HVAC."

3. Permanent-Split-Capacitor or Shaded-Pole Motors: With oil-immersed and sealed gear trains.
4. Spring-Return Motors: Equip with an integral spiral-spring mechanism where indicated. Enclose entire spring mechanism in a removable housing designed for service or adjustments. Size for running torque rating of 150 in. x lbf and breakaway torque rating of 150 in. x lbf.
5. Outdoor Motors and Motors in Outdoor-Air Intakes: Equip with O-ring gaskets designed to make motors weatherproof. Equip motors with internal heaters to permit normal operation at minus 40 deg F.
6. Nonspring-Return Motors: For dampers larger than 25 sq. ft., size motor for running torque rating of 150 in. x lbf and breakaway torque rating of 300 in. x lbf.
7. Electrical Connection: 115 V, single phase, 60 Hz.

Q. Accessories:

1. Auxiliary switches for signaling.
2. Test and reset switches mounted.

2.8 FLANGE CONNECTORS

- A. Manufacturers: Subject to compliance with requirements, provide products by one of the following:
1. Ductmate Industries, Inc.
 2. Nexus PDQ; Division of Shilco Holdings Inc.
 3. Ward Industries, Inc.; a division of Hart & Cooley, Inc.
- B. Description: Add-on or roll-formed, factory-fabricated, slide-on transverse flange connectors, gaskets, and components.
- C. Material: Galvanized steel.
- D. Gage and Shape: Match connecting ductwork.

2.9 DUCT SILENCERS

- A. Manufacturers: Subject to compliance with requirements, provide products by one of the following:
- B. Basis-of-Design Product: Subject to compliance with requirements, provide product indicated on Drawings or comparable product by one of the following:
1. Industrial Noise Control, Inc.
 2. McGill AirFlow LLC.
 3. Ruskin Company.
 4. Vibro-Acoustics.
- C. General Requirements:

1. Factory fabricated.
 2. Fire-Performance Characteristics: Adhesives, sealants, packing materials, and accessory materials shall have flame-spread index not exceeding 25 and smoke-developed index not exceeding 50 when tested according to ASTM E 84.
 3. Airstream Surfaces: Surfaces in contact with the airstream shall comply with requirements in ASHRAE 62.1-2004.
- D. Shape:
1. Rectangular straight with splitters or baffles.
 2. Round straight with center bodies or pods.
 3. Rectangular elbow with splitters or baffles.
 4. Round elbow with center bodies or pods.
 5. Rectangular transitional with splitters or baffles.
- E. Rectangular Silencer Outer Casing: ASTM A 653/A 653M, G60 (Z180), galvanized sheet steel, 0.040 inch thick.
- F. Round Silencer Outer Casing: ASTM A 653/A 653M, G60 (Z180), galvanized sheet steel.
1. Sheet Metal Thickness for Units up to 24 Inches in Diameter: 0.034 inch thick.
 2. Sheet Metal Thickness for Units 26 through 40 Inches in Diameter: 0.040 inch thick.
 3. Sheet Metal Thickness for Units 42 through 52 Inches in Diameter: 0.052 inch thick.
 4. Sheet Metal Thickness for Units 54 through 60 Inches in Diameter: 0.064 inch thick (16 GA).
- G. Inner Casing and Baffles: ASTM A 653/A 653M, G60 (Z180) galvanized sheet metal, 0.034 inch thick, and with 1/8-inch-diameter perforations.
- H. Special Construction:
1. Suitable for outdoor use.
 2. High transmission loss to achieve STC 45.
- I. Connection Sizes: Match connecting ductwork unless otherwise indicated.
- J. Principal Sound-Absorbing Mechanism:
1. Controlled impedance membranes and broadly tuned resonators without absorptive media.
 2. Dissipative type with fill material.
 - a. Fill Material: Inert and vermin-proof fibrous material, packed under not less than 5 percent compression.
 - b. Erosion Barrier: Polymer bag enclosing fill, and heat sealed before assembly.
 3. Lining: Closed Cell Foam.
- K. Fabricate silencers to form rigid units that will not pulsate, vibrate, rattle, or otherwise react to system pressure variations. Do not use mechanical fasteners for unit assemblies.

1. Lock form and seal or continuously weld joints.
2. Suspended Units: Factory-installed suspension hooks or lugs attached to frame in quantities and spaced to prevent deflection or distortion.
3. Reinforcement: Cross or trapeze angles for rigid suspension.

L. Accessories:

1. Factory-installed end caps to prevent contamination during shipping.
2. Removable splitters.
3. Airflow measuring devices.

M. Source Quality Control: Test according to ASTM E 477.

1. Testing of mockups to be witnessed by Owner.
2. Record acoustic ratings, including dynamic insertion loss and generated-noise power levels with an airflow of at least 2000-fpm face velocity.
3. Leak Test: Test units for airtightness at 200 percent of associated fan static pressure or 6-inch wg static pressure, whichever is greater.

N. Capacities and Characteristics:

1. Configuration: Straight.
2. Shape: Rectangular.
3. Attenuation Mechanism: Acoustical glass fiber with protective film liner or Closed Cell Foam.
4. Maximum Pressure Drop: 0.35-inch wg.
5. Casing:
 - a. Attenuation: Standard.
 - b. Outer Material: Galvanized steel.
 - c. Inner Material: Galvanized steel.
6. End Connection: 1-inch slip joint.
7. Accessories:
 - a. Access door.
 - b. Birdscreen.
8. See equipment schedule on Mechanical Drawings for additional requirements.

2.10 TURNING VANES

A. Manufacturers: Subject to compliance with requirements, provide products by one of the following:

1. Ductmate Industries, Inc.
2. Duro Dyne Inc.
3. METALAIR, Inc.
4. SEMCO Incorporated.
5. Ward Industries, Inc.; a division of Hart & Cooley, Inc.

- B. General Requirements: Comply with SMACNA's "HVAC Duct Construction Standards - Metal and Flexible"; Figures 2-3, "Vaness and Vane Runners," and 2-4, "Vane Support in Elbows."
- C. Vane Construction: Single or Double wall.
- D. Vane Construction: Single wall 2 inch wide for ducts up to 36 inches wide, double wall 2 inch wide from 37 inches wide to 48 inches wide and double wall 4" wide for larger dimensions.
- E. Minimum Gauge: 2" Vane – 26 GA; 4" Vane – 24 GA.

2.11 REMOTE DAMPER OPERATORS

- A. Manufacturers: Subject to compliance with requirements, provide products by one of the following:
 - 1. Pottorff; a division of PCI Industries, Inc.
 - 2. Ventfabrics, Inc.
 - 3. Young Regulator Company.
- B. Description: Cable system designed for remote manual damper adjustment.
- C. Tubing: Brass.
- D. Cable: Stainless steel.
- E. Wall-Box Mounting: Surface.
- F. Wall-Box Cover-Plate Material: Steel.

2.12 DUCT-MOUNTED ACCESS DOORS

- A. Manufacturers: Subject to compliance with requirements, provide products by one of the following:
 - 1. Cesco Products; a division of Mestek, Inc.
 - 2. Ductmate Industries, Inc.
 - 3. Flexmaster U.S.A., Inc.
 - 4. Greenheck Fan Corporation.
 - 5. McGill AirFlow LLC.
 - 6. Nailor Industries Inc.
 - 7. Ventfabrics, Inc.
 - 8. Ward Industries, Inc.; a division of Hart & Cooley, Inc.
- B. Duct-Mounted Access Doors: Fabricate access panels according to SMACNA's "HVAC Duct Construction Standards - Metal and Flexible"; Figures 2-10, "Duct Access Doors and Panels," and 2-11, "Access Panels - Round Duct."
 - 1. Door:

- a. Double wall, rectangular.
 - b. Galvanized sheet metal with insulation fill and thickness as indicated for duct pressure class.
 - c. Vision panel.
 - d. Hinges and Latches: 1-by-1-inch butt or piano hinge and cam latches.
 - e. Fabricate doors airtight and suitable for duct pressure class.
2. Frame: Galvanized sheet steel, with bend-over tabs and foam gaskets.
 3. Number of Hinges and Locks:
 - a. Access Doors Less Than 12 Inches Square: No hinges and two sash locks.
 - b. Access Doors up to 18 Inches Square: Two hinges and two sash locks.
 - c. Access Doors up to 24 by 48 Inches: Three hinges and two compression latches with outside and inside handles.
 - d. Access Doors Larger Than 24 by 48 Inches: Four hinges and two compression latches with outside and inside handles.

C. Pressure Relief Access Door:

1. Door and Frame Material: Galvanized sheet steel.
2. Door: Double wall with insulation fill with metal thickness applicable for duct pressure class.
3. Operation: Open outward for positive-pressure ducts and inward for negative-pressure ducts.
4. Factory set at 10-inch wg.
5. Doors close when pressures are within set-point range.
6. Hinge: Continuous piano.
7. Latches: Cam.
8. Seal: Neoprene or foam rubber.
9. Insulation Fill: 1-inch-thick, fibrous-glass or polystyrene-foam board.

2.13 DUCT ACCESS PANEL ASSEMBLIES

- A. Manufacturers: Subject to compliance with requirements, provide products by one of the following:
 1. Ductmate Industries, Inc.
 2. Flame Gard, Inc.
 3. 3M.
- B. Labeled according to UL 1978 by an NRTL.
- C. Panel and Frame: Minimum thickness 0.0528-inch carbon steel.
- D. Fasteners: Carbon steel. Panel fasteners shall not penetrate duct wall.
- E. Gasket: Comply with NFPA 96; grease-tight, high-temperature ceramic fiber, rated for minimum 2000 deg F.

- F. Minimum Pressure Rating: 10-inch wg, positive or negative.

2.14 FLEXIBLE CONNECTORS

- A. Manufacturers: Subject to compliance with requirements, provide products by one of the following:
 - 1. Ductmate Industries, Inc.
 - 2. Duro Dyne Inc.
 - 3. Ventfabrics, Inc.
 - 4. Ward Industries, Inc.; a division of Hart & Cooley, Inc.
- B. Materials: Flame-retardant or noncombustible fabrics.
- C. Coatings and Adhesives: Comply with UL 181, Class 1.
- D. Metal-Edged Connectors: Factory fabricated with a fabric strip 3-1/2 inches wide attached to 2 strips of 2-3/4-inch- wide, 0.028-inch-thick, galvanized sheet steel or 0.032-inch-thick aluminum sheets. Provide metal compatible with connected ducts.
- E. Indoor System, Flexible Connector Fabric: Glass fabric double coated with neoprene.
 - 1. Minimum Weight: 30 oz./sq. yd.
 - 2. Tensile Strength: 500 lbf/inch in the warp and 450 lbf/inch in the filling.
 - 3. Service Temperature: Minus 40 to plus 200 deg F.
- F. Outdoor System, Flexible Connector Fabric: Glass fabric double coated with weatherproof, synthetic rubber (Hypalon) resistant to UV rays and ozone.
 - 1. Minimum Weight: 26 oz./sq. yd.
 - 2. Minimum Tensile Strength: 225 lbf/inch in the warp and 300 lbf/inch in the filling.
 - 3. Service Temperature: Minus 40 to plus 250 deg F.
 - 4. Color: White.
- G. High-Temperature System, Flexible Connectors: Glass fabric coated with silicone rubber.
 - 1. Minimum Weight: 17 oz./sq. yd.
 - 2. Tensile Strength: 200 lbf/inch in the warp and 150 lbf/inch in the filling.
 - 3. Service Temperature: Minus 67 to plus 500 deg F.
- H. High-Corrosive-Environment System, Flexible Connectors: Glass fabric with chemical-resistant coating (Teflon).
 - 1. Minimum Weight: 16.5 oz./sq. yd.
 - 2. Tensile Strength: 400 lbf/inch in the warp and 300 lbf/inch in the filling.
 - 3. Service Temperature: Minus 150 to plus 500 deg F.
 - 4. Color: Grey Outside / Beige Inside

- I. Thrust Limits: Combination coil spring and elastomeric insert with spring and insert in compression, and with a load stop. Include rod and angle-iron brackets for attaching to fan discharge and duct.
 1. Frame: Steel, fabricated for connection to threaded rods and to allow for a maximum of 30 degrees of angular rod misalignment without binding or reducing isolation efficiency.
 2. Outdoor Spring Diameter: Not less than 80 percent of the compressed height of the spring at rated load.
 3. Minimum Additional Travel: 50 percent of the required deflection at rated load.
 4. Lateral Stiffness: More than 80 percent of rated vertical stiffness.
 5. Overload Capacity: Support 200 percent of rated load, fully compressed, without deformation or failure.
 6. Elastomeric Element: Molded, oil-resistant rubber or neoprene.
 7. Coil Spring: Factory set and field adjustable for a maximum of 1/4-inch movement at start and stop.

2.15 FLEXIBLE DUCTS

- A. Manufacturers: Subject to compliance with requirements, provide products by one of the following:
 1. Flexmaster U.S.A., Inc.
 2. McGill AirFlow LLC.
 3. Ward Industries, Inc.; a division of Hart & Cooley, Inc.
- B. Insulated, Flexible Duct: UL 181, Class 1, 2-ply vinyl film supported by helically wound, spring-steel wire; fibrous-glass insulation; polyethylene vapor-barrier film.
 1. Pressure Rating: 10-inch wg positive and 1.0-inch wg negative.
 2. Maximum Air Velocity: 4000 fpm.
 3. Temperature Range: Minus 10 to plus 160 deg F.
 4. Insulation R-value: Comply with ASHRAE/IESNA 90.1-2004.
 5. All flex duct: no greater than 5' straight run/no turns. Install per SMACNA Standards.
- C. Insulated, Flexible Duct: UL 181, Class 1, black polymer film supported by helically wound, spring-steel wire; fibrous-glass insulation; polyethylene vapor-barrier film.
 1. Pressure Rating: 4-inch wg positive and 0.5-inch wg negative.
 2. Maximum Air Velocity: 4000 fpm.
 3. Temperature Range: Minus 20 to plus 175 deg F.
 4. Insulation R-Value: Comply with ASHRAE/IESNA 90.1-2004.
- D. Flexible Duct Connectors:
 1. Clamps: Stainless-steel band with cadmium-plated hex screw to tighten band with a worm-gear action in sizes 3 through 18 inches, to suit duct size.
 2. Non-Clamp Connectors: Liquid adhesive plus tape.

2.16 DUCT ACCESSORY HARDWARE

- A. Instrument Test Holes: Cast iron or cast aluminum to suit duct material, including screw cap and gasket. Size to allow insertion of pitot tube and other testing instruments and of length to suit duct-insulation thickness.
- B. Adhesives: High strength, quick setting, neoprene based, waterproof, and resistant to gasoline and grease.

2.17 TEST PORTS

- A. Galvanized test port with gasket to seal at penetration Nominal 2 ½" tall with 5/8" test port with threaded steel cap.
- B. Basis of design Ventlok 699-2 Instrument Test Hole.

PART 3 - EXECUTION

3.1 INSTALLATION

- A. Install duct accessories according to applicable details in SMACNA's "HVAC Duct Construction Standards - Metal and Flexible" for metal ducts and in NAIMA AH116, "Fibrous Glass Duct Construction Standards," for fibrous-glass ducts.
- B. Install duct accessories of materials suited to duct materials; use galvanized-steel accessories in galvanized-steel and fibrous-glass ducts, stainless-steel accessories in stainless-steel ducts, and aluminum accessories in aluminum ducts.
- C. Install backdraft or control dampers at inlet of exhaust fans or exhaust ducts as close as possible to exhaust fan unless otherwise indicated.
- D. Install volume dampers at points on supply, return, and exhaust systems where branches extend from larger ducts. Where dampers are installed in ducts having duct liner, install dampers with hat channels of same depth as liner, and terminate liner with nosing at hat channel.
 - 1. Install steel volume dampers in steel ducts.
 - 2. Install aluminum volume dampers in aluminum ducts.
- E. Set dampers to fully open position before testing, adjusting, and balancing.
- F. Install test holes at fan inlets and outlets and elsewhere as indicated.
- G. Install fire and smoke dampers according to UL listing.
- H. Connect ducts to duct silencers rigidly.
- I. Install duct access doors on sides of ducts to allow for inspecting, adjusting, and maintaining accessories and equipment at the following locations:

1. On both sides of duct coils.
 2. Upstream and downstream from duct filters.
 3. At outdoor-air intakes and mixed-air plenums.
 4. At drain pans and seals.
 5. Downstream from manual volume dampers, control dampers, backdraft dampers, and equipment.
 6. Adjacent to and close enough to fire or smoke dampers, to reset or reinstall fusible links. Access doors for access to fire or smoke dampers having fusible links shall be pressure relief access doors and shall be outward operation for access doors installed upstream from dampers and inward operation for access doors installed downstream from dampers.
 7. At each change in direction and at maximum 50-foot spacing.
 8. Upstream and downstream from turning vanes.
 9. Upstream or downstream from duct silencers.
 10. Control devices requiring inspection.
 11. Elsewhere as indicated.
- J. Install access doors with swing against duct static pressure.
- K. Access Door Sizes:
1. One-Hand or Inspection Access: 8 by 5 inches.
 2. Two-Hand Access: 12 by 6 inches.
 3. Head and Hand Access: 18 by 10 inches.
 4. Head and Shoulders Access: 21 by 14 inches.
 5. Body Access: 25 by 14 inches.
 6. Body plus Ladder Access: 25 by 17 inches.
- L. Label access doors according to Division 23 Section "Identification for HVAC Piping and Equipment" to indicate the purpose of access door.
- M. Install flexible connectors to connect ducts to equipment.
- N. For fans developing static pressures of 5-inch wg and more, cover flexible connectors with loaded vinyl sheet held in place with metal straps.
- O. Connect terminal units to supply ducts with maximum 12-inch lengths of flexible duct. Do not use flexible ducts to change directions.
- P. Connect diffusers or light troffer boots to ducts with maximum 60-inch lengths of flexible duct clamped or strapped in place.
- Q. Connect flexible ducts to metal ducts with draw bands.
- R. Install duct test holes where required for testing and balancing purposes.
- S. Install thrust limits at centerline of thrust, symmetrical on both sides of equipment. Attach thrust limits at centerline of thrust and adjust to a maximum of 1/4-inch movement during start and stop of fans.
- T. Install flexible duct per strict adherence to SMNACA standards.

3.2 FIELD QUALITY CONTROL

A. Tests and Inspections:

1. Operate dampers to verify full range of movement.
2. Inspect locations of access doors and verify that purpose of access door can be performed.
3. Operate fire, smoke, and combination fire and smoke dampers to verify full range of movement and verify that proper heat-response device is installed.
4. Inspect turning vanes for proper and secure installation.
5. Operate remote damper operators to verify full range of movement of operator and damper.

END OF SECTION 233300

SECTION 233416 - CENTRIFUGAL HVAC FANS

PART 1 - GENERAL

1.1 RELATED DOCUMENTS

- A. Drawings and general provisions of the Contract, including General and Supplementary Conditions and Division 01 Specification Sections, apply to this Section.

1.2 SUMMARY

- A. This Section includes the following:
 - 1. Airfoil centrifugal fans.
 - 2. Backward-inclined centrifugal fans.
 - 3. Forward-curved centrifugal fans.
 - 4. Plenum fans.
 - 5. Plug fans.

1.3 PERFORMANCE REQUIREMENTS

- A. Project Altitude: Base fan performance ratings on sea level.
- B. Operating Limits: Classify according to AMCA 99.

1.4 SUBMITTALS

- A. Product Data: Include rated capacities, furnished specialties, and accessories for each type of product indicated and include the following:
 - 1. Certified fan performance curves with system operating conditions indicated.
 - 2. Certified fan sound-power ratings.
 - 3. Motor ratings and electrical characteristics, plus motor and electrical accessories.
 - 4. Material thickness and finishes, including color charts.
 - 5. Dampers, including housings, linkages, and operators.
- B. Shop Drawings: Detail equipment assemblies and indicate dimensions, weights, loads, required clearances, method of field assembly, components, and location and size of each field connection.
 - 1. Wiring Diagrams: Power, signal, and control wiring.
 - 2. Design Calculations: Calculate requirements for selecting vibration isolators and seismic restraints and for designing vibration isolation bases.

3. Vibration Isolation Base Details: Detail fabrication, including anchorages and attachments to structure and to supported equipment. Include auxiliary motor slides and rails, and base weights.
- C. Coordination Drawings: Show fan room layout and relationships between components and adjacent structural and mechanical elements. Show support locations, type of support, and weight on each support. Indicate and certify field measurements.
- D. Field quality-control test reports.
- E. Operation and Maintenance Data: For centrifugal fans to include in emergency, operation, and maintenance manuals.

1.5 QUALITY ASSURANCE

- A. Electrical Components, Devices, and Accessories: Listed and labeled as defined in NFPA 70, Article 100, by a testing agency acceptable to authorities having jurisdiction, and marked for intended use.
- B. AMCA Compliance: Products shall comply with performance requirements and shall be licensed to use the AMCA-Certified Ratings Seal.
- C. NEMA Compliance: Motors and electrical accessories shall comply with NEMA 1.
- D. UL Standards: Exhaust fans that are part of an exhaust system must be UL793 listed for 4 hours of operation at 500 °F or 1 hour of operation at 1,000°F.

1.6 DELIVERY, STORAGE, AND HANDLING

- A. Deliver fans as factory-assembled units, to the extent allowable by shipping limitations, with protective crating and covering.
- B. Disassemble and reassemble units, as required for moving to the final location, according to manufacturer's written instructions.
- C. Lift and support units with manufacturer's designated lifting or supporting points.

1.7 COORDINATION

- A. Coordinate size and location of structural-steel support members.
- B. Coordinate size and location of concrete bases. Cast anchor-bolt inserts into bases. Concrete, reinforcement, and formwork requirements are specified in Division 03.
- C. Coordinate installation of roof curbs, equipment supports, and roof penetrations. These items are specified in Division 07 Section "Roof Accessories."

1.8 EXTRA MATERIALS

- A. Furnish extra materials described below that match products installed and that are packaged with protective covering for storage and identified with labels describing contents.
 - 1. Belts: One set for each belt-driven unit.

PART 2 - PRODUCTS

2.1 AIRFOIL CENTRIFUGAL FANS

- A. Available Manufacturers: Subject to compliance with requirements, manufacturers offering products that may be incorporated into the Work include, but are not limited to, the following:
- B. Manufacturers: Subject to compliance with requirements, provide products by one of the following:
- C. Basis-of-Design Product: Subject to compliance with requirements, provide the product indicated on Drawings or a comparable product by one of the following:
 - 1. ABB Fan Group North America.
 - 2. Acme Engineering & Mfg. Corp.
 - 3. Aerovent; a Twin City Fan Company.
 - 4. Airmaster Fan Co.
 - 5. Ammerman; General Resource Corp.
 - 6. Bayley Fans; a division of Lau Industries, Inc.
 - 7. Central Blower Company.
 - 8. Chicago Blower Corporation.
 - 9. Cincinnati Fan.
 - 10. CML Northern Blower Inc.
 - 11. Greenheck.
 - 12. Howden Fan Co.
 - 13. Industrial Air; a division of Lau Industries, Inc.
 - 14. Loren Cook Company.
 - 15. Madison Manufacturing.
 - 16. New Philadelphia Fan Co.
 - 17. New York Blower Company (The).
- D. Description: Factory-fabricated, -assembled, -tested, and -finished, belt-driven centrifugal fans consisting of housing, wheel, fan shaft, bearings, motor, drive assembly, and support structure.
- E. Housings: Formed panels to make curved-scroll housings with shaped cutoff, with doors or panels to allow access to internal parts and components.
 - 1. Panel Bracing: Steel angle- or channel-iron member supports for mounting and supporting fan scroll, wheel, motor, and accessories.
 - 2. Horizontally split, bolted-flange housing.
 - 3. Spun inlet cone with flange.

4. Outlet flange.
- F. Airfoil Wheels: Single-width-single-inlet and double-width-double-inlet construction with curved inlet flange; heavy backplate; hollow die-formed, airfoil-shaped blades continuously welded at tip flange and backplate; and cast-iron or cast-steel hub riveted to backplate and fastened to shaft with set screws.
- G. Shafts: Statically and dynamically balanced and selected for continuous operation at maximum rated fan speed and motor horsepower, with final alignment and belt adjustment made after installation.
 1. Turned, ground, and polished hot-rolled steel with keyway. Ship with protective coating of lubricating oil.
 2. Designed to operate at no more than 70 percent of first critical speed at top of fan's speed range.
- H. Prelubricated and Sealed Shaft Bearings: Self-aligning, pillow-block-type ball bearings.
 1. Ball-Bearing Rating Life: ABMA 9, L10 at 120,000 hours.
 2. Roller-Bearing Rating Life: ABMA 11, L10 at 120,000 hours.
- I. Grease-Lubricated Shaft Bearings: Self-aligning, pillow-block-type, tapered roller bearings with double-locking collars and two-piece, cast-iron housing.
 1. Ball-Bearing Rating Life: ABMA 9, L10 at 120,000 hours.
 2. Roller-Bearing Rating Life: ABMA 11, L10 at 120,000 hours.
- J. Grease-Lubricated Shaft Bearings: Self-aligning, pillow-block-type, ball or roller bearings with adapter mount and two-piece, cast-iron housing.
 1. Ball-Bearing Rating Life: ABMA 9, L10 at 120,000 hours.
 2. Roller-Bearing Rating Life: ABMA 11, L10 at 120,000 hours.
- K. Belt Drives: Factory mounted, with final alignment and belt adjustment made after installation.
 1. Service Factor Based on Fan Motor Size: 1.5.
 2. Fan Pulleys: Cast iron or cast steel with split, tapered bushing; dynamically balanced at factory.
 3. Motor Pulleys: Adjustable pitch for use with motors through 5 hp; fixed pitch for use with larger motors. Select pulley so pitch adjustment is at the middle of adjustment range at fan design conditions.
 4. Belts: Oil resistant, nonsparking, and nonstatic; matched sets for multiple belt drives.
 5. Belt Guards: Fabricate to comply with OSHA and SMACNA requirements of diamond-mesh wire screen welded to steel angle frame or equivalent, prime coated. Secure to fan or fan supports without short circuiting vibration isolation. Include provisions for adjustment of belt tension, lubrication, and use of tachometer with guard in place.
 6. Motor Mount: Adjustable for belt tensioning.
- L. Accessories:

1. Scroll Access Doors: Shaped to conform to scroll, with quick-opening latches and gaskets.
 2. Cleanout Door: Quick-opening, latch-type gasketed door allowing access to fan scroll, of same material as housing.
 3. Scroll Drain Connection: NPS 1 steel pipe coupling welded to low point of fan scroll.
 4. Companion Flanges: Rolled flanges for duct connections of same material as housing.
 5. Variable Inlet Vanes: With blades supported at both ends with two permanently lubricated bearings of same material as housing. Variable mechanism terminating in single control lever with control shaft for double-width fans.
 6. Discharge Dampers: Assembly with opposed blades constructed of two plates formed around and to shaft, channel frame, and sealed ball bearings; with blades linked outside of airstream to single control lever of same material as housing.
 7. Inlet Screens: Grid screen of same material as housing.
 8. Shaft Cooler: Metal disk between bearings and fan wheel, designed to dissipate heat from shaft.
 9. Spark-Resistant Construction: AMCA 99.
 10. Shaft Seals: Airtight seals installed around shaft on drive side of single-width fans.
 11. Weather Cover: Enameled-steel sheet with ventilation slots, bolted to housing.
- M. Motors: Comply with requirements in Division 23 Section "Common Motor Requirements for HVAC Equipment."
1. Enclosure Type: Totally enclosed, fan cooled.
- N. Capacities And Characteristics: See mechanical equipment schedule on Drawings. UL793 listed for 4 hours of operation at 500 °F or 1 hour of operation at 1,000°F if exhaust application.

2.2 BACKWARD-INCLINED CENTRIFUGAL FANS

- A. Available Manufacturers: Subject to compliance with requirements, manufacturers offering products that may be incorporated into the Work include, but are not limited to, the following:
- B. Manufacturers: Subject to compliance with requirements, provide products by one of the following:
- C. Basis-of-Design Product: Subject to compliance with requirements, provide the product indicated on Drawings or a comparable product by one of the following:
1. ABB Fan Group North America.
 2. Acme Engineering & Mfg. Corp.
 3. Aerovent; a Twin City Fan Company.
 4. Airmaster Fan Co.
 5. Ammerman; General Resource Corp.
 6. Bayley Fans; a division of Lau Industries, Inc.
 7. Central Blower Company.
 8. Chicago Blower Corporation.
 9. Cincinnati Fan.
 10. CML Northern Blower Inc.
 11. Greenheck.

12. Howden Fan Co.
 13. Industrial Air; a division of Lau Industries, Inc.
 14. Loren Cook Company.
 15. Madison Manufacturing.
 16. New Philadelphia Fan Co.
 17. New York Blower Company (The).
- D. Description: Factory-fabricated, -assembled, -tested, and -finished, belt-driven centrifugal fans consisting of housing, wheel, fan shaft, bearings, motor, drive assembly, and support structure.
- E. Housings: Formed panels to make curved-scroll housings with shaped cutoff; with doors or panels to allow access to internal parts and components.
1. Panel Bracing: Steel angle- or channel-iron member supports for mounting and supporting fan scroll, wheel, motor, and accessories.
 2. Horizontally split, bolted-flange housing.
 3. Spun inlet cone with flange.
 4. Outlet flange.
- F. Backward-Inclined Wheels: Single-width-single-inlet and double-width-double-inlet construction with curved inlet flange, backplate, backward-inclined blades and fastened to shaft with set screws.
- G. Shafts: Statically and dynamically balanced and selected for continuous operation at maximum rated fan speed and motor horsepower, with final alignment and belt adjustment made after installation.
1. Turned, ground, and polished hot-rolled steel with keyway. Ship with a protective coating of lubricating oil.
 2. Designed to operate at no more than 70 percent of first critical speed at top of fan's speed range.
- H. Prelubricated and Sealed Shaft Bearings: Self-aligning, pillow-block-type ball bearings.
1. Ball-Bearing Rating Life: ABMA 9, L10 at 120,000 hours.
 2. Roller-Bearing Rating Life: ABMA 11, L10 at 120,000 hours.
- I. Grease-Lubricated Shaft Bearings: Self-aligning, pillow-block-type, tapered roller bearings with double-locking collars and two-piece, cast-iron housing.
1. Ball-Bearing Rating Life: ABMA 9, L10 at 120,000 hours.
 2. Roller-Bearing Rating Life: ABMA 11, L10 at 120,000 hours.
- J. Grease-Lubricated Shaft Bearings: Self-aligning, pillow-block-type, ball or roller bearings with adapter mount and two-piece, cast-iron housing.
1. Ball-Bearing Rating Life: ABMA 9, L10 at 120,000 hours.
 2. Roller-Bearing Rating Life: ABMA 11, L10 at 120,000 hours.
- K. Belt Drives: Factory mounted, with final alignment and belt adjustment made after installation.

1. Service Factor Based on Fan Motor Size: 1.2.
2. Fan Pulleys: Cast iron or cast steel with split, tapered bushing; dynamically balanced at factory.
3. Motor Pulleys: Adjustable pitch for use with motors through 5 hp; fixed pitch for use with larger motors. Select pulley so pitch adjustment is at the middle of adjustment range at fan design conditions.
4. Belts: Oil resistant, nonsparking, and nonstatic; matched sets for multiple belt drives.
5. Belt Guards: Fabricate to comply with OSHA and SMACNA requirements of diamond-mesh wire screen welded to steel angle frame or equivalent, prime coated. Secure to fan or fan supports without short circuiting vibration isolation. Include provisions for adjustment of belt tension, lubrication, and use of tachometer with guard in place.
6. Motor Mount: Adjustable for belt tensioning.

L. Accessories:

1. Scroll Access Doors: Shaped to conform to scroll, with quick-opening latches and gaskets.
2. Cleanout Door: Quick-opening, latch-type gasketed door allowing access to fan scroll, of same material as housing.
3. Scroll Drain Connection: NPS 1 steel pipe coupling welded to low point of fan scroll.
4. Companion Flanges: Rolled flanges for duct connections of same material as housing.
5. Variable Inlet Vanes: With blades supported at both ends with two permanently lubricated bearings of same material as housing. Variable mechanism terminating in single control lever with control shaft for double-width fans.
6. Discharge Dampers: Assembly with opposed blades constructed of two plates formed around and to shaft, channel frame, and sealed ball bearings; with blades linked outside of airstream to single control lever of same material as housing.
7. Inlet Screens: Grid screen of same material as housing.
8. Shaft Cooler: Metal disk between bearings and fan wheel, designed to dissipate heat from shaft.
9. Spark-Resistant Construction: AMCA 99.
10. Shaft Seals: Airtight seals installed around shaft on drive side of single-width fans.
11. Weather Cover: Enameled-steel sheet with ventilation slots, bolted to housing.

M. Motors: Comply with requirements in Division 23 Section "Common Motor Requirements for HVAC Equipment."

1. Enclosure Type: Totally enclosed, fan cooled.

N. Capacities And Characteristics: See mechanical equipment schedule on Drawings. UL793 listed for 4 hours of operation at 500 °F or 1 hour of operation at 1,000°F if exhaust application.

2.3 FORWARD-CURVED CENTRIFUGAL FANS

A. Available Manufacturers: Subject to compliance with requirements, manufacturers offering products that may be incorporated into the Work include, but are not limited to, the following:

B. Manufacturers: Subject to compliance with requirements, provide products by one of the following:

- C. Basis-of-Design Product: Subject to compliance with requirements, provide the product indicated on Drawings or a comparable product by one of the following:
1. ABB Fan Group North America.
 2. Acme Engineering & Mfg. Corp.
 3. Aerovent; a Twin City Fan Company.
 4. Airmaster Fan Co.
 5. Ammerman; General Resource Corp.
 6. Bayley Fans; a division of Lau Industries, Inc.
 7. Central Blower Corporation.
 8. Chicago Blower Corporation.
 9. Cincinnati Fan.
 10. CML Northern Blower Inc.
 11. Howden Fan Co.
 12. Industrial Air; a division of Lau Industries, Inc.
 13. Loren Cook Company.
 14. Madison Manufacturing.
 15. New Philadelphia Fan Co.
 16. New York Blower Company (The).
- D. Description: Factory-fabricated, -assembled, -tested, and -finished, belt-driven centrifugal fans consisting of housing, wheel, fan shaft, bearings, motor, drive assembly, and support structure.
- E. Housings: Formed panels to make curved-scroll housings with shaped cutoff; with doors or panels to allow access to internal parts and components.
1. Panel Bracing: Steel angle- or channel-iron member supports for mounting and supporting fan scroll, wheel, motor, and accessories.
 2. Horizontally split, bolted-flange housing.
 3. Spun inlet cone with flange.
 4. Outlet flange.
- F. Forward-Curved Wheels: Black-enameled or galvanized steel construction with inlet flange, backplate, shallow blades with inlet and tip curved forward in direction of airflow, mechanically secured to flange and backplate; cast-steel hub swaged to backplate and fastened to shaft with set screws.
- G. Shafts: Statically and dynamically balanced and selected for continuous operation at maximum rated fan speed and motor horsepower, with final alignment and belt adjustment made after installation.
1. Turned, ground, and polished hot-rolled steel with keyway. Ship with protective coating of lubricating oil.
 2. Designed to operate at no more than 70 percent of first critical speed at top of fan's speed range.
- H. Prelubricated and Sealed Shaft Bearings: Self-aligning, pillow-block-type ball bearings.
1. Ball-Bearing Rating Life: ABMA 9, L10 at 120,000 hours.
 2. Roller-Bearing Rating Life: ABMA 11, L10 at 120,000 hours.

- I. Grease-Lubricated Shaft Bearings: Self-aligning, pillow-block-type, tapered roller bearings with double-locking collars and two-piece, cast-iron housing.
 - 1. Ball-Bearing Rating Life: ABMA 9, L10 at 120,000 hours.
 - 2. Roller-Bearing Rating Life: ABMA 11, L10 at 120,000 hours.
- J. Grease-Lubricated Shaft Bearings: Self-aligning, pillow-block-type, ball or roller bearings with adapter mount and two-piece, cast-iron housing.
 - 1. Ball-Bearing Rating Life: ABMA 9, L10 at 120,000 hours.
 - 2. Roller-Bearing Rating Life: ABMA 11, L10 at 120,000 hours.
- K. Belt Drives: Factory mounted, with final alignment and belt adjustment made after installation.
 - 1. Service Factor Based on Fan Motor Size: 1.2.
 - 2. Fan Pulleys: Cast iron or cast steel with split, tapered bushing; dynamically balanced at factory.
 - 3. Motor Pulleys: Adjustable pitch for use with motors through 5 hp; fixed pitch for use with larger motors. Select pulley so pitch adjustment is at the middle of adjustment range at fan design conditions.
 - 4. Belts: Oil resistant, nonsparking, and nonstatic; matched sets for multiple belt drives.
 - 5. Belt Guards: Fabricate to comply with OSHA and SMACNA requirements of diamond-mesh wire screen welded to steel angle frame or equivalent, prime coated. Secure to fan or fan supports without short circuiting vibration isolation. Include provisions for adjustment of belt tension, lubrication, and use of tachometer with guard in place.
 - 6. Motor Mount: Adjustable for belt tensioning.
- L. Accessories:
 - 1. Scroll Access Doors: Shaped to conform to scroll, with quick-opening latches and gaskets.
 - 2. Cleanout Door: Quick-opening, latch-type gasketed door allowing access to fan scroll, of same material as housing.
 - 3. Scroll Drain Connection: NPS 1 steel pipe coupling welded to low point of fan scroll.
 - 4. Companion Flanges: Rolled flanges for duct connections of same material as housing.
 - 5. Variable Inlet Vanes: With blades supported at both ends with two permanently lubricated bearings of same material as housing. Variable mechanism terminating in single control lever with control shaft for double-width fans.
 - 6. Discharge Dampers: Assembly with opposed blades constructed of two plates formed around and to shaft, channel frame, and sealed ball bearings; with blades linked outside of airstream to single control lever of same material as housing.
 - 7. Inlet Screens: Grid screen of same material as housing.
 - 8. Shaft Cooler: Metal disk between bearings and fan wheel, designed to dissipate heat from shaft.
 - 9. Spark-Resistant Construction: AMCA 99.
 - 10. Shaft Seals: Airtight seals installed around shaft on drive side of single-width fans.
 - 11. Weather Cover: Enameled-steel sheet with ventilation slots, bolted to housing.
- M. Motors: Comply with requirements in Division 23 Section "Common Motor Requirements for HVAC Equipment."

1. Enclosure Type: Totally enclosed, fan cooled.

N. Capacities And Characteristics: See mechanical equipment schedule on Drawings. UL793 listed for 4 hours of operation at 500 °F or 1 hour of operation at 1,000°F if exhaust application.

2.4 PLENUM FANS

A. Available Manufacturers: Subject to compliance with requirements, manufacturers offering products that may be incorporated into the Work include, but are not limited to, the following:

B. Manufacturers: Subject to compliance with requirements, provide products by one of the following:

C. Basis-of-Design Product: Subject to compliance with requirements, provide the product indicated on Drawings or a comparable product by one of the following:

1. ABB Fan Group North America.
2. Acme Engineering & Mfg. Corp.
3. Aerovent; a Twin City Fan Company.
4. Airmaster Fan Co.
5. Ammerman; General Resource Corp.
6. Bayley Fans; a division of Lau Industries, Inc.
7. Central Blower Company.
8. Chicago Blower Corporation.
9. Cincinnati Fan.
10. CML Northern Blower Inc.
11. Howden Fan Co.
12. Industrial Air; a division of Lau Industries, Inc.
13. Loren Cook Company.
14. Madison Manufacturing.
15. New Philadelphia Fan Co.
16. New York Blower Company (The).
17. Trane.

D. Description: Factory-fabricated, -assembled, -tested, and -finished, belt-driven centrifugal fans consisting of wheel, fan shaft, bearings, motor, drive assembly, and support structure.

E. Airfoil Wheels: Single-width-single-inlet construction with smooth-curved inlet flange; heavy backplate; hollow die-formed, airfoil-shaped blades continuously welded at tip flange and backplate; and cast-iron or cast-steel hub riveted to backplate and fastened to shaft with set screws.

F. Shafts: Statically and dynamically balanced and selected for continuous operation at maximum rated fan speed and motor horsepower, with final alignment and belt adjustment made after installation.

1. Turned, ground, and polished hot-rolled steel with keyway. Ship with protective coating of lubricating oil.

2. Designed to operate at no more than 70 percent of first critical speed at top of fan's speed range.
- G. Prelubricated and Sealed Shaft Bearings: Self-aligning, pillow-block-type ball bearings.
1. Ball-Bearing Rating Life: ABMA 9, L10 at 120,000 hours.
 2. Roller-Bearing Rating Life: ABMA 11, L10 at 120,000 hours.
- H. Grease-Lubricated Shaft Bearings: Self-aligning, pillow-block-type, tapered roller bearings with double-locking collars and two-piece, cast-iron housing.
1. Ball-Bearing Rating Life: ABMA 9, L10 at 120,000 hours.
 2. Roller-Bearing Rating Life: ABMA 11, L10 at 120,000 hours.
- I. Grease-Lubricated Shaft Bearings: Self-aligning, pillow-block-type, ball or roller bearings with adapter mount and two-piece, cast-iron housing.
1. Ball-Bearing Rating Life: ABMA 9, L10 at 120,000 hours.
 2. Roller-Bearing Rating Life: ABMA 11, L10 at 120,000 hours.
- J. Belt Drives: Factory mounted, with final alignment and belt adjustment made after installation.
1. Service Factor Based on Fan Motor Size: 1.2.
 2. Fan Pulleys: Cast iron or cast steel with split, tapered bushing; dynamically balanced at factory.
 3. Motor Pulleys: Adjustable pitch for use with motors through 5 hp; fixed pitch for use with larger motors. Select pulley so pitch adjustment is at the middle of adjustment range at fan design conditions.
 4. Belts: Oil resistant, nonsparking, and nonstatic; matched sets for multiple belt drives.
 5. Belt Guards: Fabricate to comply with OSHA and SMACNA requirements of diamond-mesh wire screen welded to steel angle frame or equivalent, prime coated. Secure to fan or fan supports without short circuiting vibration isolation. Include provisions for adjustment of belt tension, lubrication, and use of tachometer with guard in place.
 6. Motor Mount: Adjustable for belt tensioning.
- K. Accessories:
1. Shaft Cooler: Metal disk between bearings and fan wheel, designed to dissipate heat from shaft.
 2. Spark-Resistant Construction: AMCA 99.
 3. Shaft Seals: Airtight seals installed around shaft on drive side of single-width fans.
- L. Motors: Comply with requirements in Division 23 Section "Common Motor Requirements for HVAC Equipment."
1. Enclosure Type: Totally enclosed, fan cooled.
- M. Capacities And Characteristics: See mechanical equipment schedule on Drawings. UL793 listed for 4 hours of operation at 500 °F or 1 hour of operation at 1,000°F if exhaust application.

2.5 PLUG FANS

- A. Available Manufacturers: Subject to compliance with requirements, manufacturers offering products that may be incorporated into the Work include, but are not limited to, the following:
- B. Manufacturers: Subject to compliance with requirements, provide products by one of the following:
- C. Basis-of-Design Product: Subject to compliance with requirements, provide the product indicated on Drawings or a comparable product by one of the following:
 - 1. ABB Fan Group North America.
 - 2. Acme Engineering & Mfg. Corp.
 - 3. Aerovent; a Twin City Fan Company.
 - 4. Airmaster Fan Co.
 - 5. Ammerman; General Resource Corp.
 - 6. Bayley Fans; a division of Lau Industries, Inc.
 - 7. Central Blower Company.
 - 8. Chicago Blower Corporation.
 - 9. Cincinnati Fan.
 - 10. CML Northern Blower Inc.
 - 11. Greenheck.
 - 12. Howden Fan Co.
 - 13. Industrial Air; a division of Lau Industries, Inc.
 - 14. Loren Cook Company.
 - 15. Madison Manufacturing.
 - 16. New Philadelphia Fan Co.
 - 17. New York Blower Company (The).
- D. Description: Factory-fabricated, -assembled, -tested, and -finished, belt-driven centrifugal fans consisting of wheel, fan shaft, bearings, motor and disconnect switch, drive assembly, and support structure.
- E. Airfoil Wheels: Single-width-single-inlet construction with smooth-curved inlet flange; heavy backplate; hollow die-formed, airfoil-shaped blades continuously welded at tip flange and backplate; and cast-iron or cast-steel hub riveted to backplate and fastened to shaft with set screws.
- F. Shafts: Statically and dynamically balanced and selected for continuous operation at maximum rated fan speed and motor horsepower, with final alignment and belt adjustment made after installation.
 - 1. Turned, ground, and polished hot-rolled steel with keyway. Ship with protective coating of lubricating oil.
 - 2. Designed to operate at no more than 70 percent of first critical speed at top of fan's speed range.
- G. Prelubricated and Sealed Shaft Bearings: Self-aligning, pillow-block-type ball bearings.
 - 1. Ball-Bearing Rating Life: ABMA 9, L10 at 120,000 hours.

2. Roller-Bearing Rating Life: ABMA 11, L10 at 120,000 hours.
 - H. Grease-Lubricated Shaft Bearings: Self-aligning, pillow-block-type, tapered roller bearings with double-locking collars and two-piece, cast-iron housing.
 1. Ball-Bearing Rating Life: ABMA 9, L10 at 120,000 hours.
 2. Roller-Bearing Rating Life: ABMA 11, L10 at 120,000 hours.
 - I. Grease-Lubricated Shaft Bearings: Self-aligning, pillow-block-type, ball or roller bearings with adapter mount and two-piece, cast-iron housing.
 1. Ball-Bearing Rating Life: ABMA 9, L10 at 120,000 hours.
 2. Roller-Bearing Rating Life: ABMA 11, L10 at 120,000 hours.
 - J. Belt Drives: Factory mounted, with final alignment and belt adjustment made after installation.
 1. Service Factor Based on Fan Motor Size: 1.2.
 2. Fan Pulleys: Cast iron or cast steel with split, tapered bushing; dynamically balanced at factory.
 3. Motor Pulleys: Adjustable pitch for use with motors through 5 hp; fixed pitch for use with larger motors. Select pulley so pitch adjustment is at the middle of adjustment range at fan design conditions.
 4. Belts: Oil resistant, nonsparking, and nonstatic; matched sets for multiple belt drives.
 5. Belt Guards: Fabricate to comply with OSHA and SMACNA requirements of diamond-mesh wire screen welded to steel angle frame or equivalent, prime coated. Secure to fan or fan supports without short circuiting vibration isolation. Include provisions for adjustment of belt tension, lubrication, and use of tachometer with guard in place.
 6. Motor Mount: Adjustable for belt tensioning.
 - K. Accessories:
 1. Shaft Cooler: Metal disk between bearings and fan wheel, designed to dissipate heat from shaft.
 2. Spark-Resistant Construction: AMCA 99.
 3. Shaft Seals: Airtight seals installed around shaft on drive side of single-width fans.
 - L. Motors: Comply with requirements in Division 23 Section "Common Motor Requirements for HVAC Equipment."
 1. Enclosure Type: Totally enclosed, fan cooled.
 - M. Capacities And Characteristics: See mechanical equipment schedule on Drawings. UL793 listed for 4 hours of operation at 500 °F or 1 hour of operation at 1,000°F if exhaust application.
- 2.6 SOURCE QUALITY CONTROL
- A. Sound-Power Level Ratings: Comply with AMCA 301, "Methods for Calculating Fan Sound Ratings from Laboratory Test Data." Factory test fans according to AMCA 300, "Reverberant Room Method for Sound Testing of Fans." Label fans with the AMCA-Certified Ratings Seal.

- B. Fan Performance Ratings: Establish flow rate, pressure, power, air density, speed of rotation, and efficiency by factory tests and ratings according to AMCA 210, "Laboratory Methods of Testing Fans for Rating."

PART 3 - EXECUTION

3.1 INSTALLATION

- A. Install centrifugal fans level and plumb.
- B. Support floor-mounting units using spring isolators having a static deflection of 1 inch. Vibration- and seismic-control devices are specified in Division 23 Section "Vibration Controls for HVAC Equipment."
 - 1. Secure vibration and seismic controls to concrete bases using anchor bolts cast in concrete base.
- C. Install floor-mounting units on concrete bases. Concrete, reinforcement, and formwork requirements are specified in Division 03 Section "Cast-in-Place Concrete."
- D. Install floor-mounting units on concrete bases designed to withstand, without damage to equipment, the seismic force required by authorities having jurisdiction. Concrete, reinforcement, and formwork requirements are specified in Division 03 Section "Cast-in-Place Concrete."
- E. Support suspended units from structure using threaded steel rods and elastomeric hangers, spring hangers having a static deflection of 1 inch. Vibration-control devices are specified in Division 23 Section "Vibration Controls for HVAC."
- F. Install units with clearances for service and maintenance.
- G. Label fans according to requirements specified in Division 23 Section "Identification for HVAC Piping and Equipment."

3.2 CONNECTIONS

- A. Duct installation and connection requirements are specified in other Division 23 Sections. Drawings indicate general arrangement of ducts and duct accessories. Make final duct connections with flexible connectors. Flexible connectors are specified in Division 23 Section "Air Duct Accessories."
- B. Install ducts adjacent to fans to allow service and maintenance.
- C. Install line-sized piping from scroll drain connection, with trap with seal equal to 1.5 times specified static pressure, to nearest floor drain.

- D. Ground equipment according to Division 26 Section "Grounding and Bonding for Electrical Systems."
- E. Connect wiring according to Division 26 Section "Low-Voltage Electrical Power Conductors and Cables."

3.3 FIELD QUALITY CONTROL

- A. Perform the following field tests and inspections and prepare test reports:
 - 1. Verify that shipping, blocking, and bracing are removed.
 - 2. Verify that unit is secure on mountings and supporting devices and that connections to ducts and electrical components are complete. Verify that proper thermal-overload protection is installed in motors, starters, and disconnect switches.
 - 3. Verify that cleaning and adjusting are complete.
 - 4. Disconnect fan drive from motor, verify proper motor rotation direction, and verify fan wheel free rotation and smooth bearing operation. Reconnect fan drive system, align and adjust belts, and install belt guards.
 - 5. Adjust belt tension.
 - 6. Adjust damper linkages for proper damper operation.
 - 7. Verify lubrication for bearings and other moving parts.
 - 8. Verify that manual and automatic volume control and fire and smoke dampers in connected ductwork systems are in fully open position.
 - 9. Refer to Division 23 Section "Testing, Adjusting, and Balancing for HVAC" for testing, adjusting, and balancing procedures.
 - 10. Remove and replace malfunctioning units and retest as specified above.
- B. Test and adjust controls and safeties. Replace damaged and malfunctioning controls and equipment.

3.4 DEMONSTRATION

- A. Engage a factory-authorized service representative to train Owner's maintenance personnel to adjust, operate, and maintain centrifugal fans. Refer to Division 01 Section "Contract Close Out."

END OF SECTION 233416

SECTION 233423 - HVAC POWER VENTILATORS

PART 1 - GENERAL

1.1 RELATED DOCUMENTS

- A. Drawings and general provisions of the Contract, including General and Supplementary Conditions and Division 01 Specification Sections, apply to this Section.

1.2 SUMMARY

- A. Section Includes:
 - 1. Utility set fans.
 - 2. Centrifugal roof ventilators.
 - 3. Axial roof ventilators.
 - 4. Upblast propeller roof exhaust fans.
 - 5. Centrifugal wall ventilators.
 - 6. Ceiling-mounted ventilators.
 - 7. In-line centrifugal fans.
 - 8. Propeller fans.

1.3 PERFORMANCE REQUIREMENTS

- A. Project Altitude: Base fan-performance ratings on sea level.
- B. Operating Limits: Classify according to AMCA 99.

1.4 SUBMITTALS

- A. Product Data: For each type of product indicated. Include rated capacities, operating characteristics, and furnished specialties and accessories. Also include the following:
 - 1. Certified fan performance curves with system operating conditions indicated.
 - 2. Certified fan sound-power ratings.
 - 3. Motor ratings and electrical characteristics, plus motor and electrical accessories.
 - 4. Material thickness and finishes, including color charts.
 - 5. Dampers, including housings, linkages, and operators.
 - 6. Roof curbs.
 - 7. Fan speed controllers.
- B. Shop Drawings: Include plans, elevations, sections, details, and attachments to other work.

1. Detail equipment assemblies and indicate dimensions, weights, loads, required clearances, method of field assembly, components, and location and size of each field connection.
 2. Wiring Diagrams: For power, signal, and control wiring.
- C. Delegated-Design Submittal: For unit hangars and supports indicated to comply with performance requirements and design criteria, including analysis data signed and sealed by the qualified professional engineer responsible for their preparation.
1. Vibration Isolation Base Details: Detail fabrication including anchorages and attachments to structure and to supported equipment. Include adjustable motor bases, rails, and frames for equipment mounting.
 2. Design Calculations: Calculate requirements for selecting vibration isolators and for designing vibration isolation bases.
- D. Coordination Drawings: Reflected ceiling plans and other details, drawn to scale, on which the following items are shown and coordinated with each other, using input from Installers of the items involved:
1. Roof framing and support members relative to duct penetrations.
 2. Ceiling suspension assembly members.
 3. Size and location of initial access modules for acoustical tile.
 4. Ceiling-mounted items including light fixtures, diffusers, grilles, speakers, sprinklers, access panels, and special moldings.
- E. Field quality-control reports.
- F. Operation and Maintenance Data: For power ventilators to include in operation, and maintenance manuals.
- 1.5 QUALITY ASSURANCE
- A. Electrical Components, Devices, and Accessories: Listed and labeled as defined in NFPA 70, by a qualified testing agency, and marked for intended location and application.
 - B. AMCA Compliance: Fans shall have AMCA-Certified performance ratings and shall bear the AMCA-Certified Ratings Seal.
 - C. UL Standards: Power ventilators shall comply with UL 705. Power ventilators for use for restaurant kitchen exhaust shall also comply with UL 762. Exhaust fans that are part of an exhaust system must be UL793 listed for 4 hours of operation at 500 °F or 1 hour of operation at 1,000°F.
- 1.6 COORDINATION
- A. Coordinate size and location of structural-steel support members.
 - B. Coordinate sizes and locations of concrete bases with actual equipment provided.

- C. Coordinate sizes and locations of roof curbs, equipment supports, and roof penetrations with actual equipment provided.

1.7 EXTRA MATERIALS

- A. Furnish extra materials that match products installed and that are packaged with protective covering for storage and identified with labels describing contents.
 - 1. Belts: One set for each belt-driven unit.

PART 2 - PRODUCTS

2.1 UTILITY SET FANS

- A. Manufacturers: Subject to compliance with requirements, provide products by one of the following manufacturers offering products that may be incorporated into the Work include, but are not limited to, the following:
- B. Basis-of-Design Product: Subject to compliance with requirements, provide product indicated on Drawings or comparable product by one of the following:
 - 1. Aerovent; a division of Twin City Fan Companies, Ltd.
 - 2. American Coolair Corporation.
 - 3. Ammerman; Millennium Equipment.
 - 4. Breidert Air Products.
 - 5. Carnes Company.
 - 6. Delhi Industries Inc.
 - 7. Greenheck.
 - 8. Hartzell Fan Incorporated.
 - 9. JencoFan.
 - 10. Loren Cook Company.
 - 11. Madison Manufacturing.
 - 12. New York Blower Company (The).
 - 13. PennBarry.
 - 14. Quietaire Inc.
 - 15. Trane; a business of American
- C. Housing: Fabricated of galvanized steel with side sheets fastened with a deep lock seam or welded to scroll sheets.
 - 1. Housing Discharge Arrangement: Adjustable to eight standard positions.
- D. Fan Wheels: Single-width, single inlet; welded to cast-iron or cast-steel hub and spun-steel inlet cone, with hub keyed to shaft.
 - 1. Blade Materials: Aluminum or Steel.
 - 2. Blade Type: Backward inclined.

3. Spark-Resistant Construction: AMCA 99, Type A—spark resistant if in laboratory application.
 4. UL793 listed for 4 hours of operation at 500 °F or 1 hour of operation at 1,000°F if exhaust application.
- E. Fan Shaft: Turned, ground, and polished steel; keyed to wheel hub.
- F. Shaft Bearings: Prelubricated and sealed, self-aligning, pillow-block-type ball bearings with ABMA 9, L₅₀ of 200,000 hours.
1. Extend grease fitting to accessible location outside of unit.
- G. Belt Drives:
1. Factory mounted, with final alignment and belt adjustment made after installation
 2. Service Factor Based on Fan Motor Size: 1.5.
 3. Motor Pulleys: Adjustable pitch for use with motors through 5 hp; fixed pitch for use with larger motors. Select pulley so pitch adjustment is at the middle of adjustment range at fan design conditions.
 4. Belts: Oil resistant, nonsparking, and nonstatic; matched sets for multiple belt drives.
 5. Belt Guards: Fabricate of steel for motors mounted on outside of fan cabinet.
- H. Accessories:
1. Inlet and Outlet: Flanged.
 2. Companion Flanges: Rolled flanges for duct connections of same material as housing.
 3. Backdraft Dampers: Gravity actuated with counterweight and interlocking aluminum blades with felt edges in steel frame installed on fan discharge.
 4. Access Door: Gasketed door in scroll with latch-type handles.
 5. Scroll Dampers: Single-blade damper installed at fan scroll top with adjustable linkage.
 6. Inlet Screens: Removable wire mesh.
 7. Drain Connections: NPS 3/4 threaded coupling drain connection installed at lowest point of housing.
 8. Weather Hoods: Weather resistant with stamped vents over motor and drive compartment.
 9. Discharge Dampers: Assembly with opposed blades constructed of two plates formed around and to shaft, channel frame, sealed ball bearings, with blades linked outside of airstream to single control lever of same material as housing.
 10. Variable Inlet Vanes: With blades supported at both ends with two permanently lubricated bearings of same material as housing. Variable mechanism terminating in single control lever with control shaft for double-width fans.
 11. Speed Controller: Solid-state control to reduce speed from 100 to less than 50 percent—specify if application warrants.
- I. Capacities and Characteristics: See mechanical equipment schedule on Drawings. UL793 listed for 4 hours of operation at 500 °F or 1 hour of operation at 1,000°F if exhaust application.

2.2 CENTRIFUGAL ROOF VENTILATORS

- A. Manufacturers: Subject to compliance with requirements, provide products by one of the following available manufacturers offering products that may be incorporated into the Work include, but are not limited to, the following:
- B. Basis-of-Design Product: Subject to compliance with requirements, provide product indicated on Drawings or comparable product by one of the following:
 - 1. Acme Engineering & Manufacturing Corporation.
 - 2. Aerovent; a division of Twin City Fan Companies, Ltd.
 - 3. American Coolair Corporation.
 - 4. Ammerman; Millennium Equipment.
 - 5. Breidert Air Products.
 - 6. Broan-NuTone LLC.
 - 7. Broan-NuTone LLC; NuTone Inc.
 - 8. Carnes Company.
 - 9. Central Blower Company.
 - 10. Delhi Industries Inc.
 - 11. Greenheck Fan Corporation.
 - 12. Hartzell Fan Incorporated.
 - 13. JencoFan.
 - 14. Loren Cook Company.
 - 15. PennBarry.
 - 16. Quietaire Inc.
 - 17. W.W. Grainger, Inc.; Dayton Products.
- C. Housing: Removable, spun-aluminum, dome top and outlet baffle; square, one-piece, aluminum base with venturi inlet cone.
 - 1. Upblast Units: Provide spun-aluminum discharge baffle to direct discharge air upward, with rain and snow drains and grease collector.
 - 2. Hinged Subbase: Galvanized-steel hinged arrangement permitting service and maintenance.
- D. Fan Wheels: Aluminum hub and wheel with backward-inclined blades.
- E. Belt Drives:
 - 1. Resiliently mounted to housing.
 - 2. Fan Shaft: Turned, ground, and polished steel; keyed to wheel hub.
 - 3. Shaft Bearings: Permanently lubricated, permanently sealed, self-aligning ball bearings.
 - 4. Pulleys: Cast-iron, adjustable-pitch motor pulley.
 - 5. Fan and motor isolated from exhaust airstream.
- F. Accessories:
 - 1. Variable-Speed Controller: Solid-state control to reduce speed from 100 to less than 50 percent.

2. Disconnect Switch: Nonfusible type, with thermal-overload protection mounted inside fan housing, factory wired through an internal aluminum conduit.
 3. Bird Screens: Removable, 1/2-inch mesh, aluminum or brass wire.
 4. Dampers: Counterbalanced, parallel-blade, backdraft dampers mounted in curb base; factory set to close when fan stops.
 5. Motorized Dampers: Parallel-blade dampers mounted in curb base with electric actuator; wired to close when fan stops.
- G. Roof Curbs: Galvanized steel; mitered and welded corners; 1-1/2-inch- thick, rigid, fiberglass insulation adhered to inside walls; and 1-1/2-inch wood nailer. Size as required to suit roof opening and fan base.
1. Configuration: Self-flashing without a cant strip, with mounting flange.
 2. Overall Height: 12 inches.
 3. Sound Curb: Curb with sound-absorbing insulation.
 4. Pitch Mounting: Manufacture curb for roof slope.
 5. Metal Liner: Galvanized steel.
 6. Burglar Bars: 5/8-inch- thick steel bars welded in place to form 6-inch squares.
 7. Mounting Pedestal: Galvanized steel with removable access panel.
 8. Vented Curb: Unlined with louvered vents in vertical sides.
- H. Capacities and Characteristics: See mechanical equipment schedule on Drawings. UL793 listed for 4 hours of operation at 500 °F or 1 hour of operation at 1,000°F if exhaust application.

2.3 AXIAL ROOF VENTILATORS

- A. Manufacturers: Subject to compliance with requirements, provide products by one of the following available manufacturers offering products that may be incorporated into the Work include, but are not limited to, the following:
- B. Basis-of-Design Product: Subject to compliance with requirements, provide product indicated on Drawings or comparable product by one of the following:
1. Acme Engineering & Manufacturing Corporation.
 2. Aerovent; a division of Twin City Fan Companies, Ltd.
 3. American Coolair Corporation.
 4. Ammerman; Millennium Equipment.
 5. Breidert Air Products.
 6. Carnes Company.
 7. FloAire.
 8. Greenheck Fan Corporation.
 9. Hartzell Fan Incorporated.
 10. Loren Cook Company.
 11. New York Blower Company (The).
 12. PennBarry.
 13. Stanley Fans.
- C. Housing: Heavy-gage, removable, spun-aluminum, dome top and outlet baffle; square, one-piece, hinged, aluminum base.

1. Hinged Subbase: Galvanized-steel hinged arrangement permitting service and maintenance.
- D. Fan Wheel: Aluminum or Steel hub and blades.
- E. Belt Drives:
1. Resiliently mounted to housing.
 2. Fan Shaft: Turned, ground, and polished steel; keyed to wheel hub.
 3. Shaft Bearings: Permanently lubricated, permanently sealed, self-aligning ball bearings.
 4. Pulleys: Cast-iron, adjustable-pitch motor pulley.
- F. Accessories:
1. Disconnect Switch: Nonfusible type, with thermal-overload protection mounted inside fan housing, factory wired through an internal aluminum conduit.
 2. Bird Screens: Removable, 1/2-inch mesh, aluminum or brass wire.
 3. Dampers: Counterbalanced, parallel-blade, backdraft dampers mounted in curb base; factory set to close when fan stops.
 4. Motorized Dampers: Parallel-blade dampers mounted in curb base with electric actuator; wired to close when fan stops.
- G. Roof Curbs: Galvanized steel; mitered and welded corners; 1-1/2-inch-thick, rigid, fiberglass insulation adhered to inside walls; and 1-1/2-inch wood nailer. Size as required to suit roof opening and fan base.
1. Configuration: Self-flashing without a cant strip, with mounting flange.
 2. Overall Height: 12 inches.
 3. Sound Curb: Curb with sound-absorbing insulation.
 4. Pitch Mounting: Manufacture curb for roof slope.
 5. Metal Liner: Galvanized steel.
 6. Burglar Bars: 5/8-inch-thick steel bars welded in place to form 6-inch squares as required.
 7. Mounting Pedestal: Galvanized steel with removable access panel.
- H. Capacities and Characteristics: See mechanical equipment schedule on Drawings. UL793 listed for 4 hours of operation at 500 °F or 1 hour of operation at 1,000°F if exhaust application.
- 2.4 UPBLAST PROPELLER ROOF EXHAUST FANS
- A. Manufacturers: Subject to compliance with requirements, provide products by one of the following available manufacturers offering products that may be incorporated into the Work include, but are not limited to, the following:
- B. Basis-of-Design Product: Subject to compliance with requirements, provide product indicated on Drawings or comparable product by one of the following:
1. Acme Engineering & Manufacturing Corporation.
 2. Aerovent; a division of Twin City Fan Companies, Ltd.

3. American Coolair Corporation.
 4. Ammerman; Millennium Equipment.
 5. Breidert Air Products.
 6. Carnes Company.
 7. Cincinnati Fan.
 8. Greenheck Fan Corporation.
 9. Hartzell Fan Incorporated.
 10. JencoFan.
 11. Loren Cook Company.
 12. Madison Manufacturing.
 13. New York Blower Company (The).
 14. PennBarry.
 15. Quietaire Inc.
 16. Stanley Fans.
- C. Wind Band, Fan Housing, and Base: Reinforced and braced galvanized steel, containing galvanized-steel butterfly dampers and rain trough, motor and drive assembly, and fan wheel.
1. Damper Rods: Steel with bronze bearings.
 2. Hinged Subbase: Galvanized-steel hinged arrangement permitting service and maintenance.
- D. Fan Wheel: Replaceable, cast-aluminum, airfoil blades fastened to cast-aluminum hub; factory set pitch angle of blades.
- E. Belt Drives:
1. Resiliently mounted to housing.
 2. Weatherproof housing of same material as fan housing.
 3. Fan Shaft: Turned, ground, and polished steel; keyed to wheel hub.
 4. Shaft Bearings: Prelubricated and sealed, self-aligning, pillow-block-type ball bearings.
 5. Pulleys: Cast-iron, adjustable-pitch motor pulley.
 6. Motor Mount: On outside of fan cabinet, adjustable base for belt tensioning.
- F. Roof Curbs: Galvanized steel; mitered and welded corners; 1-1/2-inch- thick, rigid, fiberglass insulation adhered to inside walls; and 1-1/2-inch wood nailer. Size as required to suit roof opening and fan base.
1. Configuration: Self-flashing without a cant strip, with mounting flange.
 2. Overall Height: 12 inches.
 3. Sound Curb: Curb with sound-absorbing insulation.
 4. Pitch Mounting: Manufacture curb for roof slope.
 5. Metal Liner: Galvanized steel.
 6. Burglar Bars: 5/8-inch- thick steel bars welded in place to form 6-inch squares as required.
 7. Mounting Pedestal: Galvanized steel with removable access panel.
- G. Capacities and Characteristics: See mechanical equipment schedule on Drawings. UL793 listed for 4 hours of operation at 500 °F or 1 hour of operation at 1,000°F if exhaust application.

2.5 CENTRIFUGAL WALL VENTILATORS

- A. Manufacturers: Subject to compliance with requirements, provide products by one of the following available manufacturers offering products that may be incorporated into the Work include, but are not limited to, the following:
- B. Basis-of-Design Product: Subject to compliance with requirements, provide product indicated on Drawings or comparable product by one of the following:
 - 1. Acme Engineering & Manufacturing Corporation.
 - 2. Aerovent; a division of Twin City Fan Companies, Ltd.
 - 3. American Coolair Corporation.
 - 4. Ammerman; Millennium Equipment.
 - 5. Breidert Air Products.
 - 6. Carnes Company.
 - 7. Greenheck Fan Corporation.
 - 8. Hartzell Fan Incorporated.
 - 9. JencoFan.
 - 10. Loren Cook Company.
 - 11. PennBarry.
 - 12. W.W. Grainger, Inc.; Dayton Products.
- C. Housing: Heavy-gage, removable, spun-aluminum, dome top and outlet baffle; venturi inlet cone.
- D. Fan Wheel: Aluminum hub and wheel with backward-inclined blades.
- E. Belt Drives:
 - 1. Resiliently mounted to housing.
 - 2. Fan Shaft: Turned, ground, and polished steel; keyed to wheel hub.
 - 3. Shaft Bearings: Permanently lubricated, permanently sealed, self-aligning ball bearings.
 - 4. Pulleys: Cast-iron, adjustable-pitch motor pulley.
 - 5. Fan and motor isolated from exhaust airstream.
- F. Accessories:
 - 1. Variable-Speed Controller: Solid-state control to reduce speed from 100 to less than 50 percent.
 - 2. Disconnect Switch: Nonfusible type, with thermal-overload protection mounted inside fan housing, factory wired through internal aluminum conduit.
 - 3. Bird Screens: Removable, 1/2-inch mesh, aluminum or brass wire.
 - 4. Wall Grille: Ring type for flush mounting.
 - 5. Dampers: Counterbalanced, parallel-blade, backdraft dampers mounted in wall sleeve; factory set to close when fan stops.
 - 6. Motorized Dampers: Parallel-blade dampers mounted in curb base with electric actuator; wired to close when fan stops.
- G. Capacities and Characteristics: See mechanical equipment schedule on Drawings.

2.6 CEILING-MOUNTED VENTILATORS

- A. Manufacturers: Subject to compliance with requirements, provide products by one of the following available manufacturers offering products that may be incorporated into the Work include, but are not limited to, the following:
- B. Basis-of-Design Product: Subject to compliance with requirements, provide product indicated on Drawings or comparable product by one of the following:
 - 1. American Coolair Corporation.
 - 2. Ammerman; Millennium Equipment.
 - 3. Breidert Air Products.
 - 4. Broan-NuTone LLC.
 - 5. Broan-NuTone LLC; NuTone Inc.
 - 6. Carnes Company.
 - 7. FloAire.
 - 8. Greenheck Fan Corporation.
 - 9. JencoFan.
 - 10. Loren Cook Company.
 - 11. PennBarry.
 - 12. W.W. Grainger, Inc.; Dayton Products.
- C. Housing: Steel, lined with acoustical insulation.
- D. Fan Wheel: Centrifugal wheels directly mounted on motor shaft. Fan shrouds, motor, and fan wheel shall be removable for service.
- E. Grille: Plastic, louvered grille with flange on intake and thumbscrew attachment to fan housing.
- F. Electrical Requirements: Junction box for electrical connection on housing and receptacle for motor plug-in.
- G. Accessories:
 - 1. Variable-Speed Controller: Solid-state control to reduce speed from 100 to less than 50 percent.
 - 2. Manual Starter Switch: Single-pole rocker switch assembly with cover and pilot light.
 - 3. Time-Delay Switch: Assembly with single-pole rocker switch, timer, and cover plate.
 - 4. Motion Sensor: Motion detector with adjustable shutoff timer.
 - 5. Ceiling Radiation Damper: Fire-rated assembly with ceramic blanket, stainless-steel springs, and fusible link.
 - 6. Filter: Washable aluminum to fit between fan and grille.
 - 7. Isolation: Rubber-in-shear vibration isolators.
 - 8. Manufacturer's standard roof jack or wall cap, and transition fittings.
- H. Capacities and Characteristics: See mechanical equipment schedule on Drawings.

2.7 IN-LINE CENTRIFUGAL FANS

- A. Manufacturers: Subject to compliance with requirements, provide products by one of the following available manufacturers offering products that may be incorporated into the Work include, but are not limited to, the following:
- B. Basis-of-Design Product: Subject to compliance with requirements, provide product indicated on Drawings or comparable product by one of the following:
 - 1. Acme Engineering & Manufacturing Corporation.
 - 2. American Coolair Corporation.
 - 3. Ammerman; Millennium Equipment.
 - 4. Breidert Air Products.
 - 5. Carnes Company.
 - 6. FloAire.
 - 7. Greenheck Fan Corporation.
 - 8. Hartzell Fan Incorporated.
 - 9. JencoFan.
 - 10. Loren Cook Company.
 - 11. Madison Manufacturing.
 - 12. PennBarry.
 - 13. Quietaire Inc.
- C. Housing: Split, spun aluminum with aluminum straightening vanes, inlet and outlet flanges, and support bracket adaptable to floor, side wall, or ceiling mounting.
- D. Direct-Drive Units: Motor mounted in airstream, factory wired to disconnect switch located on outside of fan housing.
- E. Belt-Driven Units: Motor mounted on adjustable base, with adjustable sheaves, enclosure around belts within fan housing, and lubricating tubes from fan bearings extended to outside of fan housing.
- F. Fan Wheels: Aluminum, airfoil blades welded to aluminum hub.
- G. Accessories:
 - 1. Variable-Speed Controller: Solid-state control to reduce speed from 100 to less than 50 percent.
 - 2. Volume-Control Damper: Manually operated with quadrant lock, located in fan outlet.
 - 3. Companion Flanges: For inlet and outlet duct connections.
 - 4. Fan Guards: 1/2- by 1-inch mesh of galvanized steel in removable frame. Provide guard for inlet or outlet for units not connected to ductwork.
 - 5. Motor and Drive Cover (Belt Guard): Epoxy-coated steel.
- H. Capacities and Characteristics: See mechanical equipment schedule on Drawings. UL793 listed for 4 hours of operation at 500 °F or 1 hour of operation at 1,000°F if exhaust application.

2.8 PROPELLER FANS

- A. Manufacturers: Subject to compliance with requirements, provide products by one of the following available manufacturers offering products that may be incorporated into the Work include, but are not limited to, the following:
- B. Basis-of-Design Product: Subject to compliance with requirements, provide product indicated on Drawings or comparable product by one of the following:
1. Acme Engineering & Manufacturing Corporation.
 2. Aerovent; a division of Twin City Fan Companies, Ltd.
 3. Airmaster Fan Company.
 4. American Coolair Corporation.
 5. Ammerman; Millennium Equipment.
 6. Breidert Air Products.
 7. Carnes Company.
 8. Chicago Blower Corporation.
 9. Cincinnati Fan.
 10. Hartzell Fan Incorporated.
 11. Howden Buffalo Inc.
 12. JencoFan.
 13. King Company; part of Mestek, Inc.
 14. Loren Cook Company.
 15. Madison Manufacturing.
 16. Moffitt Corporation Inc.
 17. New York Blower Company (The).
 18. PennBarry.
 19. W.W. Grainger, Inc.; Dayton Products.
- C. Housing: Galvanized-steel sheet with flanged edges and integral orifice ring with baked-enamel finish coat applied after assembly.
- D. Steel Fan Wheels: Formed-steel blades riveted to heavy-gage steel spider bolted to cast-iron hub.
- E. Fan Wheel: Replaceable, cast-aluminum, airfoil blades fastened to cast-aluminum hub; factory set pitch angle of blades.
- F. Fan Drive: Motor mounted in airstream, factory wired to disconnect switch located on outside of fan housing.
- G. Fan Drive:
1. Resiliently mounted to housing.
 2. Statically and dynamically balanced.
 3. Selected for continuous operation at maximum rated fan speed and motor horsepower, with final alignment and belt adjustment made after installation.
 4. Extend grease fitting to accessible location outside of unit.
 5. Service Factor Based on Fan Motor Size: 1.4.
 6. Fan Shaft: Turned, ground, and polished steel; keyed to wheel hub.

7. Shaft Bearings: Permanently lubricated, permanently sealed, self-aligning ball bearings.
 - a. Ball-Bearing Rating Life: ABMA 9, L_{10} of 100,000 hours.
8. Pulleys: Cast iron with split, tapered bushing; dynamically balanced at factory.
9. Motor Pulleys: Adjustable pitch for use with motors through 5 hp; fixed pitch for use with larger motors. Select pulley so pitch adjustment is at the middle of adjustment range at fan design conditions.
10. Belts: Oil resistant, nonsparking, and nonstatic; matched sets for multiple belt drives.
11. Belt Guards: Fabricate of steel for motors mounted on outside of fan cabinet.

H. Accessories:

1. Gravity Shutters: Aluminum blades in aluminum frame; interlocked blades with nylon bearings.
2. Motor-Side Back Guard: Galvanized steel, complying with OSHA specifications, removable for maintenance.
3. Wall Sleeve: Galvanized steel to match fan and accessory size.
4. Weathershield Hood: Galvanized steel to match fan and accessory size.
5. Weathershield Front Guard: Galvanized steel with expanded metal screen.
6. Variable-Speed Controller: Solid-state control to reduce speed from 100 to less than 50 percent.
7. Disconnect Switch: Nonfusible type, with thermal-overload protection mounted inside fan housing, factory wired through an internal aluminum conduit.

- I. Capacities and Characteristics: See mechanical equipment schedule on Drawings. UL793 listed for 4 hours of operation at 500 °F or 1 hour of operation at 1,000°F if exhaust application.

2.9 MOTORS

- A. Comply with NEMA designation, temperature rating, service factor, enclosure type, and efficiency requirements for motors specified in Division 23 Section "Common Motor Requirements for HVAC Equipment."

1. Motor Sizes: Minimum size as indicated. If not indicated, large enough so driven load will not require motor to operate in service factor range above 1.0.
2. Controllers, Electrical Devices, and Wiring: Comply with requirements for electrical devices and connections specified in Division 26 Sections.

- B. Enclosure Type: Totally enclosed, fan cooled.

2.10 SOURCE QUALITY CONTROL

- A. Certify sound-power level ratings according to AMCA 301, "Methods for Calculating Fan Sound Ratings from Laboratory Test Data." Factory test fans according to AMCA 300, "Reverberant Room Method for Sound Testing of Fans." Label fans with the AMCA-Certified Ratings Seal.

- B. Certify fan performance ratings, including flow rate, pressure, power, air density, speed of rotation, and efficiency by factory tests according to AMCA 210, "Laboratory Methods of Testing Fans for Aerodynamic Performance Rating." Label fans with the AMCA-Certified Ratings Seal.

PART 3 - EXECUTION

3.1 INSTALLATION

- A. Install power ventilators level and plumb.
- B. Support units using elastomeric mounts spring isolators having a static deflection of 1 inch. Vibration- and seismic-control devices are specified in Division 23 Section "Vibration Controls for HVAC."
 - 1. Secure vibration and seismic controls to concrete bases using anchor bolts cast in concrete base.
- C. Install floor-mounted units on concrete bases. Concrete, reinforcement, and formwork requirements are specified in Division 03 Section "Cast-in-Place Concrete."
- D. Install floor-mounted units on concrete bases designed to withstand, without damage to equipment, the seismic force required by code. Concrete, reinforcement, and formwork requirements are specified in Division 03 Section "Cast-in-Place Concrete."
- E. Secure roof-mounted fans to roof curbs with cadmium-plated hardware. See Division 07 Section "Roof Accessories" for installation of roof curbs.
- F. Ceiling Units: Suspend units from structure; use steel wire or metal straps.
- G. Support suspended units from structure using threaded steel rods and elastomeric hangers spring hangers having a static deflection of 1 inch. Vibration-control devices are specified in Division 23 Section "Vibration Controls for HVAC."
- H. Install units with clearances for service and maintenance.
- I. Label units according to requirements specified in Division 23 Section "Identification for HVAC Piping and Equipment."

3.2 CONNECTIONS

- A. Duct installation and connection requirements are specified in other Division 23 Sections. Drawings indicate general arrangement of ducts and duct accessories. Make final duct connections with flexible connectors. Flexible connectors are specified in Division 23 Section "Air Duct Accessories."
- B. Install ducts adjacent to power ventilators to allow service and maintenance.

- C. Ground equipment according to Division 26 Section "Grounding and Bonding for Electrical Systems."
- D. Connect wiring according to Division 26 Section "Low-Voltage Electrical Power Conductors and Cables."

3.3 FIELD QUALITY CONTROL

- A. Perform tests and inspections.
 - 1. Manufacturer's Field Service: Engage a factory-authorized service representative to inspect components, assemblies, and equipment installations, including connections, and to assist in testing.
- B. Tests and Inspections:
 - 1. Verify that shipping, blocking, and bracing are removed.
 - 2. Verify that unit is secure on mountings and supporting devices and that connections to ducts and electrical components are complete. Verify that proper thermal-overload protection is installed in motors, starters, and disconnect switches.
 - 3. Verify that cleaning and adjusting are complete.
 - 4. Disconnect fan drive from motor, verify proper motor rotation direction, and verify fan wheel free rotation and smooth bearing operation. Reconnect fan drive system, align and adjust belts, and install belt guards.
 - 5. Adjust belt tension.
 - 6. Adjust damper linkages for proper damper operation.
 - 7. Verify lubrication for bearings and other moving parts.
 - 8. Verify that manual and automatic volume control and fire and smoke dampers in connected ductwork systems are in fully open position.
 - 9. Disable automatic temperature-control operators, energize motor and adjust fan to indicated rpm, and measure and record motor voltage and amperage.
 - 10. Shut unit down and reconnect automatic temperature-control operators.
 - 11. Remove and replace malfunctioning units and retest as specified above.
- C. Test and adjust controls and safeties. Replace damaged and malfunctioning controls and equipment.
- D. Prepare test and inspection reports.

3.4 ADJUSTING

- A. Adjust damper linkages for proper damper operation.
- B. Adjust belt tension.
- C. Comply with requirements in Division 23 Section "Testing, Adjusting, and Balancing for HVAC" for testing, adjusting, and balancing procedures.

- D. Replace fan and motor pulleys as required to achieve design airflow.
- E. Lubricate bearings.

END OF SECTION 233423

SECTION 233600 - AIR TERMINAL UNITS

PART 1 - GENERAL

1.1 RELATED DOCUMENTS

- A. Drawings and general provisions of the Contract, including General and Supplementary Conditions and Division 01 Specification Sections, apply to this Section.

1.2 SUMMARY

- A. Section Includes:
 - 1. Bypass, single-duct air terminal units.
 - 2. Dual-duct air terminal units.
 - 3. Fan-powered air terminal units.
 - 4. Shutoff, single-duct air terminal units.
 - 5. Venturi Air Valves

1.3 PERFORMANCE REQUIREMENTS

- A. Structural Performance: Hangers and supports shall withstand the effects of gravity loads and stresses within limits and under conditions described in SMACNA's "HVAC Duct Construction Standards - Metal and Flexible".

1.4 SUBMITTALS

- A. Product Data: For each type of the following products, including rated capacities, furnished specialties, sound-power ratings, and accessories.
 - 1. Air terminal units.
 - 2. Liners and adhesives.
 - 3. Sealants and gaskets.
- B. Shop Drawings: For air terminal units. Include plans, elevations, sections, details, and attachments to other work.
 - 1. Detail equipment assemblies and indicate dimensions, weights, loads, required clearances, method of field assembly, components, and location and size of each field connection.
 - 2. Wiring Diagrams: For power, signal, and control wiring.
 - 3. Hangers and supports, including methods for duct and building attachment and vibration isolation.

- C. Coordination Drawings: Reflected ceiling plans, drawn to scale, on which the following items are shown and coordinated with each other, using input from Installers of the items involved:
 - 1. Ceiling suspension assembly members.
 - 2. Size and location of initial access modules for acoustic tile.
 - 3. Ceiling-mounted items including lighting fixtures, diffusers, grilles, speakers, sprinklers, access panels, and special moldings.
- D. Field quality-control reports.
- E. Operation and Maintenance Data: For air terminal units to include in emergency, operation, and maintenance manuals. In addition to items specified in Division 01 Section "Operation and Maintenance Data," include the following:
 - 1. Instructions for resetting minimum and maximum air volumes.
 - 2. Instructions for adjusting software set points.

1.5 QUALITY ASSURANCE

- A. Electrical Components, Devices, and Accessories: Listed and labeled as defined in NFPA 70, by a qualified testing agency, and marked for intended location and application.

1.6 EXTRA MATERIALS

- A. Furnish extra materials that match products installed and that are packaged with protective covering for storage and identified with labels describing contents.
 - 1. Fan-Powered-Unit Filters: Furnish one spare filter for each filter installed.

PART 2 - PRODUCTS

2.1 BYPASS, SINGLE-DUCT AIR TERMINAL UNITS

- A. Manufacturers: Subject to compliance with requirements, provide products by one of the following available manufacturers offering products that may be incorporated into the Work include, but are not limited to, the following:
- B. Basis-of-Design Product: Subject to compliance with requirements, provide product indicated on Drawings or comparable product by one of the following:
 - 1. Metalaire
 - 2. Price
 - 3. Carrier
 - 4. Trane
 - 5. Krueger
 - 6. Nailor
 - 7. Titus.

- C. Configuration: Diverting-damper assembly inside unit casing with control components inside a protective metal shroud.
- D. Casing: 0.034-inch steel double wall.
 - 1. Casing Lining: Adhesive attached, 1/2-inch- internally lined with engineered polymer foam insulation which complies to UL181 and NFPA 90A. Insulation shall be 1½ pound density, closed cell foam. Exposed fiberglass is not acceptable. The insulation shall be mechanically fastened to the unit casing. The casing shall be constructed to hold leakage to the maximum values shown in the Casing Leakage table. Liner shall have a maximum flame-spread index of 25 and a maximum smoke-developed index of 50, for both insulation and adhesive, when tested according to ASTM E 84.
 - 2. Air Inlet: Round stub connection for duct attachment.
 - 3. Air Outlet: S-slip and drive connections.
 - 4. Access: Removable panels for access to diverting damper and other parts requiring service, adjustment, or maintenance; with airtight gasket.
 - 5. Airstream Surfaces: Surfaces in contact with the airstream shall comply with requirements in ASHRAE 62.1-2004.
- E. Diverter Assembly: Galvanized-steel gate, with polyethylene linear bearings Aluminum blade, with nylon-fitted pivot points.
- F. Hydronic Coils: Copper tube, with mechanically bonded aluminum fins spaced no closer than 0.1 inch , and rated for a minimum working pressure of 200 psig and a maximum entering-water temperature of 220 deg F . Include manual air vent and drain valve.
- G. Electric-Resistance Heating Coils: Nickel-chromium heating wire, free of expansion noise and hum, mounted in ceramic inserts in a galvanized-steel housing; with primary automatic, and secondary manual, reset thermal cutouts. Terminate elements in stainless-steel, machine-staked terminals secured with stainless-steel hardware.
 - 1. Access door interlocked disconnect switch.
 - 2. Downstream air temperature sensor with local connection to override discharge-air temperature to not exceed a maximum temperature set point (adjustable.)
 - 3. Nickel chrome 80/20 heating elements.
 - 4. Airflow switch for proof of airflow.
 - 5. Fuses in terminal box for overcurrent protection (for coils more than 48 A).
 - 6. Mercury contactors.
 - 7. BACNET switches and relays.
 - 8. Magnetic contactor for each step of control (for three-phase coils).
- A. Electronic Controls must be native BACNET: Bidirectional damper operator and microprocessor-based thermostat with integral airflow transducer and room sensor. Control devices shall be compatible with temperature controls specified in Division 23 Section "Direct Digital Control (DDC) for HVAC" and shall have the following features:
 - 1. Damper Actuator: 24 V, powered closed, spring return open.
 - 2. Velocity Controller: Factory calibrated and field adjustable to minimum and maximum air volumes; shall maintain constant airflow dictated by thermostat within 5 percent of set point while compensating for inlet static-pressure variations up to 4-inch wg ; and shall

have a multipoint velocity sensor. Locate velocity sensors in cold-deck air inlets and air outlets.

3. Thermostat: Refer to Division 23 Section "Direct Digital Control (DDC) for HVAC"

2.2 DUAL-DUCT AIR TERMINAL UNITS

- A. Basis-of-Design Product: Subject to compliance with requirements, provide product indicated on Drawings or comparable product by one of the following:
 1. Krueger.
 2. METALAIR, Inc.
 3. Nailor Industries Inc.
 4. Price Industries.
 5. Titus.
 6. Trane; a business of American Standard Companies.
- B. Configuration: Two volume dampers inside unit casing with mixing attenuator section and control components inside a protective metal shroud.
- C. Casing: 0.034-inch (0.85-mm) steel double wall.
 1. Casing Lining: Adhesive attached, 1/2-inch- internally lined with engineered polymer foam insulation which complies to UL181 and NFPA 90A. Insulation shall be 1½ pound density, closed cell foam. Exposed fiberglass is not acceptable. The insulation shall be mechanically fastened to the unit casing. The casing shall be constructed to hold leakage to the maximum values shown in the Casing Leakage table. Liner shall have a maximum flame-spread index of 25 and a maximum smoke-developed index of 50, for both insulation and adhesive, when tested according to ASTM E 84.
 2. Air Inlets: Round stub connections or S-slip and drive connections for duct attachment.
 3. Air Outlet: S-slip and drive connections.
 4. Access: Removable panels for access to parts requiring service, adjustment, or maintenance; with airtight gasket.
 5. Airstream Surfaces: Surfaces in contact with the airstream shall comply with requirements in ASHRAE 62.1-2004.
- D. Volume Damper: Galvanized steel with peripheral gasket and self-lubricating bearings.
 1. Maximum Damper Leakage: ARI 880 rated, 3 percent of nominal airflow at 3-inch wg inlet static pressure.
- E. Velocity Sensors: Multipoint array with velocity sensors in cold- and hot-deck air inlets and air outlets.
- F. Attenuator Section: 0.034-inch steel sheet.
 1. Lining: Adhesive attached, 3/4-inch- thick, polyurethane foam insulation complying with UL 181 erosion requirements, and having a maximum flame-spread index of 25 and a maximum smoke-developed index of 50, for both insulation and adhesive, when tested according to ASTM E 84.

2. Airstream Surfaces: Surfaces in contact with the airstream shall comply with requirements in ASHRAE 62.1-2004.
- G. Electronic Controls must be native BACNET: Bidirectional damper operator and microprocessor-based thermostat with integral airflow transducer and room sensor. Control devices shall be compatible with temperature controls specified in Division 23 Section "Direct Digital Control (DDC) for HVAC" and shall have the following features:
1. Damper Actuator: 24 V, powered closed, spring return open.
 2. Velocity Controller: Factory calibrated and field adjustable to minimum and maximum air volumes; shall maintain constant airflow dictated by thermostat within 5 percent of set point while compensating for inlet static-pressure variations up to 4-inch wg ; and shall have a multipoint velocity sensor. Locate velocity sensors in cold-deck air inlets and air outlets.
 3. Thermostat: Refer to Division 23 Section "Direct Digital Control (DDC) for HVAC"
- H. Direct Digital Controls: Single-package unitary controller and actuator specified in Division 23 Section "Direct Digital Control (DDC) for HVAC."

2.3 PARALLEL FAN-POWERED AIR TERMINAL UNITS

- A. Basis-of-Design Product: Subject to compliance with requirements, provide product indicated on Drawings or comparable product by one of the following:
1. Environmental Technologies, Inc.
 2. Krueger.
 3. METALAIRE, Inc.
 4. Nailor Industries Inc.
 5. Price Industries.
 6. Titus.
 7. Trane; a business of American Standard Companies.
- B. Configuration: Volume-damper assembly and fan in parallel arrangement inside unit casing with control components inside a protective metal shroud.
- C. Casing: 0.034-inch steel double wall.
1. Casing Lining: Adhesive attached, 1/2-inch- internally lined with engineered polymer foam insulation which complies to UL181 and NFPA 90A. Insulation shall be 1½ pound density, closed cell foam. Exposed fiberglass is not acceptable. The insulation shall be mechanically fastened to the unit casing. The casing shall be constructed to hold leakage to the maximum values shown in the Casing Leakage table. Liner shall have a maximum flame-spread index of 25 and a maximum smoke-developed index of 50, for both insulation and adhesive, when tested according to ASTM E 84.
 2. Air Inlets: Round stub connections or S-slip and drive connections for duct attachment.
 3. Air Outlet: S-slip and drive connections.
 4. Access: Removable panels for access to parts requiring service, adjustment, or maintenance; with airtight gasket and quarter-turn latches.
 5. Fan: Forward-curved centrifugal, located at plenum air inlet.

6. Airstream Surfaces: Surfaces in contact with the airstream shall comply with requirements in ASHRAE 62.1-2004.
- D. Volume Damper: Galvanized steel with flow-sensing ring and peripheral gasket and self-lubricating bearings.
1. Maximum Damper Leakage: ARI 880 rated, 2 percent of nominal airflow at 3-inch wg inlet static pressure.
 2. Damper Position: Normally open.
- E. Velocity Sensors: Multipoint array with velocity sensors in cold- and hot-deck air inlets and air outlets.
- F. Motor:
1. Comply with NEMA designation, temperature rating, service factor, enclosure type, and efficiency requirements for motors specified in Division 23 Section "Common Motor Requirements for HVAC Equipment."
 2. Type: Permanent-split capacitor with SCR for speed adjustment or Electronically commutated motor.
 3. Fan-Motor Assembly Isolation: Rubber isolators.
 4. See equipment schedule on mechanical drawings for additional requirements.
 5. Efficiency: Premium efficient.
 6. Electrical Characteristics:
- G. Filters: Minimum arrestance according to ASHRAE 52.1 and a minimum efficiency reporting value (MERV) according to ASHRAE 52.2.
1. Material: Polyurethane foam having 70 percent arrestance and 3 MERV.
 2. Material: Glass fiber treated with adhesive; having 80 percent arrestance and 5 MERV.
 3. Material: Pleated cotton-polyester media having 90 percent arrestance and 7 MERV.
 4. Thickness: 1 inch.
- H. Attenuator Section: 0.034-inch steel sheet.
1. Lining: Adhesive attached, 3/4-inch- thick, polyurethane foam insulation complying with UL 181 erosion requirements, and having a maximum flame-spread index of 25 and a maximum smoke-developed index of 50, for both insulation and adhesive, when tested according to ASTM E 84.
 2. Airstream Surfaces: Surfaces in contact with the airstream shall comply with requirements in ASHRAE 62.1-2004.
- I. Hydronic Coils: Copper tube, with mechanically bonded aluminum fins spaced no closer than 0.1 inch , and rated for a minimum working pressure of 200 psig and a maximum entering-water temperature of 220 deg F . Include manual air vent and drain valve.
1. Location: Plenum air inlet.

- J. Electric-Resistance Heating Coils: Nickel-chromium heating wire, free of expansion noise and hum, mounted in ceramic inserts in a galvanized-steel housing; with primary automatic, and secondary manual, reset thermal cutouts. Terminate elements in stainless-steel, machine-staked terminals secured with stainless-steel hardware.
 - 1. Location: Plenum air inlet.
 - 2. Stages: SCR control required.
 - 3. Access door interlocked disconnect switch.
 - 4. Downstream air temperature sensor with local connection to override discharge-air temperature to not exceed a maximum temperature set point (adjustable.)
 - 5. Nickel chrome 80/20 heating elements.
 - 6. Airflow switch for proof of airflow.
 - 7. Fan interlock contacts.
 - 8. Fuses in terminal box for overcurrent protection (for coils more than 48 A).
 - 9. Mercury contactors.
 - 10. BACNET switches and relays.
 - 11. Magnetic contactor for each step of control (for three-phase coils).

- K. Factory-Mounted and -Wired Controls: Electrical components mounted in control box with removable cover. Incorporate single-point electrical connection to power source.
 - 1. Control Transformer: Factory mounted for control voltage on electric and electronic control units with terminal strip in control box for field wiring of thermostat and power source.
 - 2. Wiring Terminations: Fan and controls to terminal strip. Terminal lugs to match quantities, sizes, and materials of branch-circuit conductors. Enclose terminal lugs in terminal box that is sized according to NFPA 70.
 - 3. Disconnect Switch: Factory-mounted, fuse type.

- L. Control Panel Enclosure: NEMA 250, Type 1, with access panel sealed from airflow and mounted on side of unit.

- A. Electronic Controls must be native BACNET: Bidirectional damper operator and microprocessor-based thermostat with integral airflow transducer and room sensor. Control devices shall be compatible with temperature controls specified in Division 23 Section "Direct Digital Control (DDC) for HVAC" and shall have the following features:
 - 1. Damper Actuator: 24 V, powered closed, spring return open.
 - 2. Velocity Controller: Factory calibrated and field adjustable to minimum and maximum air volumes; shall maintain constant airflow dictated by thermostat within 5 percent of set point while compensating for inlet static-pressure variations up to 4-inch wg ; and shall have a multipoint velocity sensor. Locate velocity sensors in cold-deck air inlets and air outlets.
 - 3. Thermostat: Refer to Division 23 Section "Direct Digital Control (DDC) for HVAC"

2.4 SERIES FAN-POWERED AIR TERMINAL UNITS

- A. Basis-of-Design Product: Subject to compliance with requirements, provide product indicated on Drawings or comparable product by one of the following:

1. Anemostat Products; a Mestek Company.
 2. Carnes.
 3. Environmental Technologies, Inc.
 4. Krueger.
 5. METALAIRE, Inc.
 6. Nailor Industries Inc.
 7. Price Industries.
 8. Titus.
 9. Trane; a business of American Standard Companies.
 10. Tuttle & Bailey.
- B. Configuration: Volume-damper assembly and fan in series arrangement inside unit casing with control components inside a protective metal shroud for installation above a ceiling.
- C. Casing: 0.034-inch steel single wall.
1. Casing Lining: Adhesive attached, 1/2-inch- internally lined with engineered polymer foam insulation which complies to UL181 and NFPA 90A. Insulation shall be 1½ pound density, closed cell foam. Exposed fiberglass is not acceptable. The insulation shall be mechanically fastened to the unit casing. The casing shall be constructed to hold leakage to the maximum values shown in the Casing Leakage table. Liner shall have a maximum flame-spread index of 25 and a maximum smoke-developed index of 50, for both insulation and adhesive, when tested according to ASTM E 84.
 2. Air Inlets: Round stub connections or S-slip and drive connections for duct attachment.
 3. Air Outlet: S-slip and drive connections.
 4. Access: Removable panels for access to parts requiring service, adjustment, or maintenance; with airtight gasket and quarter-turn latches.
 5. Fan: Forward-curved centrifugal.
 6. Airstream Surfaces: Surfaces in contact with the airstream shall comply with requirements in ASHRAE 62.1-2004.
- D. Volume Damper: Galvanized steel with flow-sensing ring and peripheral gasket and self-lubricating bearings.
1. Maximum Damper Leakage: ARI 880 rated, 2 percent of nominal airflow at 3-inch wg inlet static pressure.
 2. Damper Position: Normally open.
- E. Velocity Sensors: Multipoint array with velocity sensors in cold- and hot-deck air inlets and air outlets.
- F. Motor:
1. Comply with NEMA designation, temperature rating, service factor, enclosure type, and efficiency requirements for motors specified in Division 23 Section "Common Motor Requirements for HVAC Equipment."
 2. Type: Permanent-split capacitor with SCR for speed adjustment or Electronically commutated motor.
 3. Fan-Motor Assembly Isolation: Rubber isolators.

4. Efficiency: Premium efficient.
 5. Motor Speed: Single speed
 - a. Speed Control: Infinitely adjustable with electronic controls.
 6. Electrical Characteristics: See mechanical equipment schedule on drawings.
- G. Filters: Minimum arrestance according to ASHRAE 52.1 and a minimum efficiency reporting value (MERV) according to ASHRAE 52.2.
1. Material: Polyurethane foam having 70 percent arrestance and 3 MERV.
 2. Material: Glass fiber treated with adhesive; having 80 percent arrestance and 5 MERV.
 3. Material: Pleated cotton-polyester media having 90 percent arrestance and 7 MERV.
 4. Thickness: 1 inch.
- H. Attenuator Section: 0.034-inch steel sheet.
1. Lining: Adhesive attached, 3/4-inch- thick, polyurethane foam insulation complying with UL 181 erosion requirements, and having a maximum flame-spread index of 25 and a maximum smoke-developed index of 50, for both insulation and adhesive, when tested according to ASTM E 84.
 2. Airstream Surfaces: Surfaces in contact with the airstream shall comply with requirements in ASHRAE 62.1-2004.
- I. Hydronic Coils: Copper tube, with mechanically bonded aluminum fins spaced no closer than 0.1 inch , and rated for a minimum working pressure of 200 psig and a maximum entering-water temperature of 220 deg F . Include manual air vent and drain valve.
- J. Electric-Resistance Heating Coils: Nickel-chromium heating wire, free of expansion noise and hum, mounted in ceramic inserts in a galvanized-steel housing; with primary automatic, and secondary manual, reset thermal cutouts. Terminate elements in stainless-steel, machine-staked terminals secured with stainless-steel hardware.
1. Stage(s): SCR control required.
 2. Access door interlocked disconnect switch.
 3. Downstream air temperature sensor with local connection to override discharge-air temperature to not exceed a maximum temperature set point (adjustable.)
 4. Nickel chrome 80/20 heating elements.
 5. Airflow switch for proof of airflow.
 6. Fan interlock contacts.
 7. Fuses in terminal box for overcurrent protection (for coils more than 48 A).
 8. Mercury contactors.
 9. BACNET switches and relays.
 10. Magnetic contactor for each step of control (for three-phase coils).
- K. Factory-Mounted and -Wired Controls: Electrical components mounted in control box with removable cover. Incorporate single-point electrical connection to power source.

1. Control Transformer: Factory mounted for control voltage on electric and electronic control units with terminal strip in control box for field wiring of thermostat and power source.
 2. Wiring Terminations: Fan and controls to terminal strip. Terminal lugs to match quantities, sizes, and materials of branch-circuit conductors. Enclose terminal lugs in terminal box that is sized according to NFPA 70.
 3. Disconnect Switch: Factory-mounted, fuse type.
- L. Control Panel Enclosure: NEMA 250, Type 1, with access panel sealed from airflow and mounted on side of unit.
- A. Electronic Controls must be native BACNET: Bidirectional damper operator and microprocessor-based thermostat with integral airflow transducer and room sensor. Control devices shall be compatible with temperature controls specified in Division 23 Section "Direct Digital Control (DDC) for HVAC" and shall have the following features:
1. Damper Actuator: 24 V, powered closed, spring return open.
 2. Velocity Controller: Factory calibrated and field adjustable to minimum and maximum air volumes; shall maintain constant airflow dictated by thermostat within 5 percent of set point while compensating for inlet static-pressure variations up to 4-inch wg ; and shall have a multipoint velocity sensor. Locate velocity sensors in cold-deck air inlets and air outlets.
 3. Thermostat: Refer to Division 23 Section "Direct Digital Control (DDC) for HVAC"

2.5 SHUTOFF, SINGLE-DUCT AIR TERMINAL UNITS

- A. Basis-of-Design Product: Subject to compliance with requirements, provide product indicated on Drawings or comparable product by one of the following:
1. Environmental Technologies, Inc.
 2. Krueger.
 3. METALAIRE, Inc.
 4. Nailor Industries Inc.
 5. Phoenix Controls Corporation.
 6. Price Industries.
 7. Titus.
 8. Trane; a business of American Standard Companies.
 9. Trox USA Inc.; a subsidiary of the TROX GROUP.
- B. Configuration: Volume-damper assembly inside unit casing with control components inside a protective metal shroud.
- C. Casing: 0.034-inch steel single wall.
1. Casing Lining: Adhesive attached, 1/2-inch- internally lined with engineered polymer foam insulation which complies to UL181 and NFPA 90A. Insulation shall be 1½ pound density, closed cell foam. Exposed fiberglass is not acceptable. The insulation shall be mechanically fastened to the unit casing. The casing shall be constructed to hold leakage

- to the maximum values shown in the Casing Leakage table. Liner shall have a maximum flame-spread index of 25 and a maximum smoke-developed index of 50, for both insulation and adhesive, when tested according to ASTM E 84.
2. Air Inlet: Round stub connection or S-slip and drive connections for duct attachment.
 3. Air Outlet: S-slip and drive connections.
 4. Access: Removable panels for access to parts requiring service, adjustment, or maintenance; with airtight gasket.
 5. Airstream Surfaces: Surfaces in contact with the airstream shall comply with requirements in ASHRAE 62.1-2004.
- D. Regulator Assembly: System-air-powered bellows section incorporating polypropylene bellows for volume regulation and thermostatic control. Bellows shall operate at temperatures from 0 to 140 deg F , shall be impervious to moisture and fungus, shall be suitable for 10-inch wg static pressure, and shall be factory tested for leaks.
- E. Volume Damper: Galvanized steel with peripheral gasket and self-lubricating bearings.
1. Maximum Damper Leakage: ARI 880 rated, 2 percent of nominal airflow at 3-inch wg inlet static pressure.
 2. Damper Position: Normally open.
- F. Attenuator Section: 0.034-inch steel sheet.
1. Lining: Adhesive attached, 3/4-inch- thick, polyurethane foam insulation complying with UL 181 erosion requirements, and having a maximum flame-spread index of 25 and a maximum smoke-developed index of 50, for both insulation and adhesive, when tested according to ASTM E 84.
 2. Airstream Surfaces: Surfaces in contact with the airstream shall comply with requirements in ASHRAE 62.1-2004.
- G. Hydronic Coils: Copper tube, with mechanically bonded aluminum fins spaced no closer than 0.1 inch , and rated for a minimum working pressure of 200 psig and a maximum entering-water temperature of 220 deg F . Include manual air vent and drain valve.
- H. Electric-Resistance Heating Coils: Nickel-chromium heating wire, free of expansion noise and hum, mounted in ceramic inserts in a galvanized-steel housing; with primary automatic, and secondary manual, reset thermal cutouts. Terminate elements in stainless-steel, machine-staked terminals secured with stainless-steel hardware.
1. Access door interlocked disconnect switch.
 2. Downstream air temperature sensor with local connection to override discharge-air temperature to not exceed a maximum temperature set point (adjustable.)
 3. Nickel chrome 80/20 heating elements.
 4. Airflow switch for proof of airflow.
 5. Fan interlock contacts.
 6. Fuses in terminal box for overcurrent protection (for coils more than 48 A).
 7. Mercury contactors.
 8. BACNET switches and relays.
 9. Magnetic contactor for each step of control (for three-phase coils).

- I. Electronic Controls must be native BACNET: Bidirectional damper operator and microprocessor-based thermostat with integral airflow transducer and room sensor. Control devices shall be compatible with temperature controls specified in Division 23 Section "Direct Digital Control (DDC) for HVAC" and shall have the following features:
 - 1. Damper Actuator: 24 V, powered closed, spring return open.
 - 2. Velocity Controller: Factory calibrated and field adjustable to minimum and maximum air volumes; shall maintain constant airflow dictated by thermostat within 5 percent of set point while compensating for inlet static-pressure variations up to 4-inch wg; and shall have a multipoint velocity sensor at air inlet.
 - 3. Thermostat: Refer to Division 23 Section "Direct Digital Control (DDC) for HVAC."
- J. Direct Digital Controls: Single-package unitary controller and actuator specified in Division 23 Section "Direct Digital Control (DDC) for HVAC."

2.6 VENTURI AIR VALVES

- A. Venturi air valves and control components shall be furnished to control the airflow into and out of critical spaces and non-critical spaces in the building. The associated BAS DDC controller shall vary the amount of make-up/supply air into the room to operate the spaces at the lowest possible airflow rates necessary to maintain temperature control, achieve minimum ventilation rates and maintain room pressurization in relation to adjacent spaces (positive or negative).
- B. Provide all wiring or installation of any other components associated with the lab monitoring and control. Provide factory start up and provisions for labor to support calibration of Venturi Air Valves along with TAB contractor.
- C. The plans and specifications for the venturi air valves are based on systems and equipment manufactured by Phoenix Controls. Venturi air valves shall be required where indicated. Refer to mechanical schedules for venturi air valves required to be standard shutoff. All venturi air valves required to be low-pressure drop where option is available.
- D. Substitute Limitations:
 - 1. In strict accordance with this specification, alternative air valves equipment shall only be considered for approval provided that the equipment be equal in every respect to the operational characteristics, capacities and intent of control sequence specified herein. Approval to bid does not relieve the air valve supplier from complying with the minimum requirements of or intent of this specification.
 - 2. An alternate laboratory air valve utilized by UMD is the Accuvalve manufactured by Accutrol. This may be submitted as an alternate laboratory control system and where it is proposed to be applied it must be able to be applied seamlessly into existing building HVAC and control systems.
 - 3. The Engineer and Owner shall be the sole judges of quality and equivalence of equipment, materials, methods and life cycle cost.
 - 4. Only those systems specifically named in this specification or by addendum shall be considered for approval. Other systems submitted after the bid opening will be returned without review.

- E. Phoenix Controls Neutralizers: These sound cancellation devices may be used for laboratory exhaust venturi air valves in lieu of standard duct-mounted sound attenuators. Furnish neutralizers constructed of 316 SS for chemical fume hood exhaust; galvanized steel construction every else.
- F. The Architect/Engineer and Owner shall be the sole judges of quality and equivalence of equipment, materials, methods and life cycle costs.

2.7 VENTURI AIR VALVE COMPONENTS

A. Venturi Air Valves – General

- 1. Venturi air valve for fume hoods shall be Celeris® venturi air valves with high speed electric actuation. Venturi air valves for all other applications shall be Vantage® base upgradeable venturi air valves for tiered solutions with medium speed electric actuation.
- 2. The venture air valve valve assembly manufacturer’s Quality Management System shall be registered to ISO 9001:2008.
- 3. The venture air valve shall be pressure independent over its specified differential static pressure operating range. An integral pressure-independent assembly shall respond and maintain specific airflow within one second of a change in duct static pressure regardless of the magnitude of pressure (from 0.3 in W.C. to 3.0 in W.C.) (74.7 Pa to 747 Pa) and/or flow change or quantity of airflow controllers on a manifolded system.
- 4. The venture air valve shall maintain accuracy within $\pm 5\%$ of signal over an airflow turndown range of no less than:

Pressure Drop Range	Airflow	Turndown	Device Type
Devices up to 1,000 CFM (472 l/s)		20 to 1	Standard
Devices up to 1,500 CFM (708 l/s)		16 to 1	Standard
Devices up to 2,500 CFM (1,180 l/s)		12 to 1	Standard
Devices up to 850 CFM (401 l/s)		17 to 1	Shutoff 0.6- 3.0-inch W.C.
Devices up to 1,300 CFM (614 l/s)		14 to 1	Shutoff 0.3- 3.0-inch W.C.
Devices up to 550 CFM (260 l/s)		11 to 1	Standard
Devices up to 1,050 CFM (496 l/s)		11 to 1	Standard

- 5. No minimum entrance or exit duct diameters shall be required to ensure accuracy and/or pressure independence. No rotational/axial orientation requirements shall be required to ensure accuracy and/or pressure independence.
- 6. Venturi air valve shall maintain pressure independence regardless of loss of power.
- 7. Venturi air valve shall be constructed of one of the following four types:
 - a. Class A: Venturi air valve for non-corrosive airstreams, such as supply and general exhaust, shall be constructed of 16-gauge aluminum. The device's shaft and internal “S” link shall be made of 316 stainless steel. The shaft support brackets shall be made of galvaneal. The pivot arm shall be made of aluminum. The pressure independent springs shall be a spring-grade stainless steel. All shaft bearing surfaces shall be made of a PP (polypropylene) or PPS (polyphenylene sulfide) composite. Sound attenuating devices used in conjunction with general exhaust or supply venturi air valves shall be constructed using 24 gauge galvanized steel or other suitable material used in standard duct construction. No sound absorptive materials of any kind shall be used.

- b. Class B: Venturi air valve for corrosive airstreams, such as fume hoods and biosafety cabinets, shall have a baked-on, corrosion resistant phenolic coating. The device's shaft shall be made of 316 stainless steel with a Teflon coating. The shaft support brackets shall be made of 316 stainless steel. The pivot arm and internal "S" link shall be made of 316 or 303 stainless steel. The pressure independent springs shall be a spring-grade stainless steel. The internal nuts, bolts and rivets shall be stainless steel. All shaft bearing surfaces shall be made of PP (polypropylene) or PPS (polyphenylene sulfide) composite.
 - c. Class C: Venturi air valve for highly corrosive airstreams shall be constructed as defined in 2.2.B.6.B. In addition, these devices shall have no exposed aluminum or stainless steel components. Shaft support brackets, pivot arm, and pressure independent springs shall have a baked-on, corrosion-resistant phenolic coating in addition to the materials defined in 2.2.B.6.B. The internal "S" link, nuts, bolts, and rivets shall be epoxy phenolic coated stainless steel. Only devices clearly defined as "high corrosion resistant" on project drawings will require this construction.
 - d. PVDF: Venturi air valve for extremely corrosive airstreams, such as acid digestion fume hoods, shall have a PVDF (polyvinylidene fluoride fluoropolymer) coating. The device's shaft shall be made of 316 stainless steel with a Teflon coating. The shaft support brackets shall be made of 316 stainless steel with PVDF coating. The pivot arm and internal mounting link shall be made of 316 or 303 stainless steel with PVDF coating. The pressure independent springs shall be a spring-grade stainless steel with PVDF coating. The internal nuts, bolts and rivets shall be stainless steel with PVDF coating. All shaft bearing surfaces shall be made of Teflon or PPS (polyphenylene sulfide) composite. Only devices clearly defined as "extremely corrosion resistant" on project drawings will require this construction
8. Actuation
 - a. Celeris- For electrically actuated VAV operation, a CE certified electronic actuator shall be factory mounted to the venturi air valve. Loss of main power shall cause the venture air valve to position itself in an appropriate failsafe state. Options for these failsafe states include: normally open-maximum position, normally closed-minimum position and last position. This position shall be maintained constantly without external influence, regardless of external conditions on the venturi air valve (within product specifications).
 - b. Vantage- A medium-speed electric actuator shall be used to modulate the airflow over the range of the specific venturi air valve size. The maximum time to modulate from minimum to maximum flow shall be less than 90 seconds. A UL or CSA listed electronic actuator shall be factory mounted to the venturi air valve. The actuator shall have sufficient torque to modulate the airflow against the maximum duct static pressure (within product specifications). Loss of main power shall cause the venturi air valve to maintain its last airflow position. This position shall be maintained until power is restored.
9. The shutoff ventura Air valve shall have shutoff and casing leakage of no more than:
 - Shutoff devices up to 850 CFM (472 l/s) 6 CFM 0.12 CFM/ ft²
 - Shutoff devices up to 1,300 CFM (708 l/s) 6 CFM 0.12 CFM/ ft²
 - Low leakage shutoff devices up to 850 CFM (472 l/s) 0.005 CFM 0.010 CFM/ ft²
 - Low leakage shutoff devices up to 1,300 CFM (708 l/s) 0.010 CFM 0.010 CFM/ ft²
10. The controller for the venture air valves shall be microprocessor based and fully BACNET compatible.

11. Each laboratory control system shall have the capability of performing fume hood control, pressurization control, temperature control, humidity control, and implement occupancy and emergency mode control schemes.
12. Certification
 - a. Each venturi air valve shall be factory characterized using NIST-traceable air stations and instrumentation having a combined error no greater than $\pm 1\%$ of signal over the entire range of measurement. Electronic venturi air valves shall be characterized to $\pm 5\%$ of signal at a minimum of 48 different airflows across the full operating range of the device. All flow data for any given device shall be stored at the factory and be available on presentation of a serial number within 24 hours. Flow data for all venturi air valves shall be stored at a location away from the factory for disaster recovery purposes
 - b. Each venturi air valve shall be marked with the room number, tag number, serial number, and, model number. All information shall be stored by the manufacturer for use with as-built documentation.

B. Exhaust and Supply Airflow Device Controller

1. One controller shall be supplied for both the supply venturi air valve and the corresponding exhaust air control device.
2. Venturi air valve shall be a microprocessor-based design and shall use closed loop control to linearly regulate airflow based on a digital control signal. The device shall generate a digital feedback signal that represents its airflow.
3. Venturi air valve shall store its control algorithms in non-volatile, re-writeable memory.
4. The venturi air valve shall use 24 VAC power $\pm 15\%$, the industry standard
5. The venturi air valve shall be able to connect a notebook PC commissioning tool
6. Venturi air valve shall have built-in integral input/output connections that address fume hood control, temperature control, humidity control occupancy control, emergency control, and non-network sensors switches and control devices. At a minimum, the airflow controller shall have:
 - a. Three universal inputs capable of accepting 0 to 10 VAC, 4 to 20 mA, 0 to 65 K ohms, or Type 2 or Type 3 10 K ohm @ 25°C thermistor temperature sensors
 - b. One digital input capable of accepting a dry contact or logic level signal input.
 - c. Two analog outputs capable of developing either a 0 to 10 VAC or 4 to 20 mA linear control signal.
 - d. One Form C (SPDT) relay output capable of driving up to 1 A @ 24 VAC.
7. Venturi air valve shall meet FCC Part 15 Subpart J Class A, CE, and CSA Listed per file #228219.

2.8 ACCEPTABLE VENTURI MANUFACTURES

A. Manufacturer List

1. The plans and specifications for the venturi air valves are based on systems and equipment manufactured by Phoenix Controls. Venturi air valves and associated products.
2. Listed manufacturers
 - a. Critical Room Control (CRC)
 - b. TSI Venturi Valve Pressure-Independent Devices
 - c. Price Industries Model VV venturi air valves
 - d. Siemens Models AVC/AVV venturi air valves

B. Substitute Limitations

1. In strict accordance with this specification, alternative venturi air valves and equipment shall only be considered for approval provided that the equipment be equal in every respect to the operational characteristics, capacities and intent of control sequences specified herein. Approval to bid does not relieve the venturi air valves supplier from complying with the minimum requirements or intent of this specification.
2. The Engineer and Owner shall be the sole judges of quality and equivalence of equipment, materials, methods and life cycle cost.
3. Only those systems specifically named in this specification or by addendum shall be considered for approval. Other systems submitted after the bid opening will be returned without review.

2.9 VENTURI PERFORMANCE REQUIREMENTS

- A. Each critical and non-critical airflow control zone shall have a dedicated BAS DDC controller provided by BAS contractor.
- B. The hood exhaust venturi air valve shall be switched automatically between in-use and standby levels based on the operator's presence immediately in front of the hood. A presence and motion sensor shall activate the switching. Venturi air valve shall achieve the required in-use commanded value in less than one second from the moment of detection with no more than a 5% overshoot or undershoot.
- C. Venturi air valves shall maintain specific airflow ($\pm 5\%$ of signal within one second of a change in duct static pressure) regardless of the magnitude of the pressure change, airflow change or quantity of venturi air valves on either the supply air or exhaust air manifold (within 0.3 to 3.0" W.C.).
- D. BAS DDC controller and venturi air valves shall use volumetric offset control to maintain room pressurization. The system shall maintain proper room pressurization polarity (negative or positive) regardless of any change in room/system conditions, such as rapid changes in duct static pressure. Systems using differential pressure measurement or velocity measurement to control room pressurization are unacceptable.
- E. The venturi air valves shall maintain specific airflow ($\pm 5\%$ of signal) with a minimum 11 to 1 airflow turndown to ensure accurate pressurization at low airflow and assure maximum energy efficiency.
- F. In the event of a power failure, venturi air valves shall fail to the last position and continue to maintain flow control within $\pm 5\%$ of signal within one second of a change in duct static pressure.
- G. Venturi Air Valve Sound Specifications:
 1. Venturi air valves manufacturer shall provide comprehensive sound power level data for each size venturi air valve. All data shall be obtained from testing in accordance with ASHRAE/ANSI Standard 130, Methods of Testing Air Terminal Units.

2.10 VENTURI ADVANCED PRESSURE MONITOR (SENSOR, TRANSMITTER, DISPLAY).

- A. Provide pressure-to-current transmitters with the following minimum specifications:
1. Color, touch-screen display.
 2. Resistant to spray wash-down (IP-54 rated).
 3. Multi-function input signal of 0-10 VAC, 0-5 VAC or 4- 20 mA.
 4. Standard accuracy RSS of at least +/-0.5% full scale (non-linearity, hysteresis and non-repeatability).
 5. Optional high accuracy RSS of at least +/-0.25% full scale (non-linearity, hysteresis and nonrepeatability).
 6. Integral zero and span adjustment.
 7. Temperature effect on zero/span shift ± 0.03 % FS/ $^{\circ}$ F.
 8. Pressure ranges, selected by Engineer shall be up to (-1.0" to +1.0").
 9. Temperature Range: 32 to 120 $^{\circ}$ F
 10. Programmable visual alarm and adjustable audible alarm.
 11. Alarm contact output, SPDT, contact rating of 2.0A @ 30 VAC, 0.6A @ 125 VAC.
- B. Acceptable Products
1. Phoenix Controls Model APM200.
 2. Sensors are required as indicated on the drawings or control diagrams.

2.11 VENTURI SYSTEM ROOM AIR PRESSURE SENSOR PLATE

- A. Provide shielded static air probes for sensing room pressure levels. Probes shall be flush-mounted in a standard 2" x 4" electrical box.
- B. The pressure -sensing tubing shall be connected to the top of the probe with quarter-inch tubing. Tubing shall also be extended from the pressure sensor to a stable common pressure reference port.
- C. The exact placement of the sensor plates and means of establishing a stable common reference pressure shall be determined by the Engineer.

2.12 HANGERS AND SUPPORTS

- A. Hanger Rods for Noncorrosive Environments: Cadmium-plated steel rods and nuts.
- B. Hanger Rods for Corrosive Environments: Electrogalvanized, all-thread rods or galvanized rods with threads painted with zinc-chromate primer after installation.
- C. Steel Cables: Galvanized steel complying with ASTM A 603.
- D. Steel Cable End Connections: Cadmium-plated steel assemblies with brackets, swivel, and bolts designed for duct hanger service; with an automatic-locking and clamping device.
- E. Air Terminal Unit Attachments: Sheet metal screws, blind rivets, or self-tapping metal screws; compatible with duct materials.

- F. Trapeze and Riser Supports: Steel shapes and plates for units with steel casings; aluminum for units with aluminum casings.

2.13 SOURCE QUALITY CONTROL

- A. Factory Tests: Test assembled air terminal units according to ARI 880.
 - 1. Label each air terminal unit with plan number, nominal airflow, maximum and minimum factory-set airflows, coil type, and ARI certification seal.

PART 3 - EXECUTION

3.1 INSTALLATION

- A. Install air terminal units according to NFPA 90A, "Standard for the Installation of Air Conditioning and Ventilating Systems."
- B. Install air terminal units level and plumb. Maintain sufficient clearance for normal service and maintenance.
- C. Install wall-mounted thermostats.

3.2 HANGER AND SUPPORT INSTALLATION

- A. Comply with SMACNA's "HVAC Duct Construction Standards - Metal and Flexible," Chapter 4, "Hangers and Supports."
- B. Building Attachments: Concrete inserts, powder-actuated fasteners, or structural-steel fasteners appropriate for construction materials to which hangers are being attached.
 - 1. Where practical, install concrete inserts before placing concrete.
 - 2. Install powder-actuated concrete fasteners after concrete is placed and completely cured.
 - 3. Use powder-actuated concrete fasteners for standard-weight aggregate concretes and for slabs more than 4 inches thick.
 - 4. Do not use powder-actuated concrete fasteners for lightweight-aggregate concretes and for slabs less than 4 inches thick.
 - 5. Do not use powder-actuated concrete fasteners for seismic restraints.
- C. Hangers Exposed to View: Threaded rod and angle or channel supports.
- D. Install upper attachments to structures. Select and size upper attachments with pull-out, tension, and shear capacities appropriate for supported loads and building materials where used.

3.3 CONNECTIONS

- A. Install piping adjacent to air terminal unit to allow service and maintenance.

- B. Hot-Water Piping: In addition to requirements in Division 23 Section "Hydronic Piping," connect heating coils to supply with shutoff valve, strainer, control valve, and union or flange; and to return with balancing valve and union or flange.
- C. Connect ducts to air terminal units according to Division 23 Section "Metal Ducts."
- D. Provide duct access door upstream of heating coil to facilitate coil cleaning.
- E. Make connections to air terminal units with flexible connectors complying with requirements in Division 23 Section "Air Duct Accessories."

3.4 IDENTIFICATION

- A. Label each air terminal unit with plan number, nominal airflow, and maximum and minimum factory-set airflows. Comply with requirements in Division 23 Section "Identification for HVAC Piping and Equipment" for equipment labels and warning signs and labels.

3.5 FIELD QUALITY CONTROL

- A. Testing Agency: Engage a qualified testing agency to perform tests and inspections.
- B. Manufacturer's Field Service: Engage a factory-authorized service representative to inspect, test, and adjust components, assemblies, and equipment installations, including connections.
- C. Perform tests and inspections.
 - 1. Manufacturer's Field Service: Engage a factory-authorized service representative to inspect components, assemblies, and equipment installations, including connections, and to assist in testing.
- D. Tests and Inspections:
 - 1. After installing air terminal units and after electrical circuitry has been energized, test for compliance with requirements.
 - 2. Leak Test: After installation, fill water coils and test for leaks. Repair leaks and retest until no leaks exist.
 - 3. Operational Test: After electrical circuitry has been energized, start units to confirm proper motor rotation and unit operation.
 - 4. Test and adjust controls and safeties. Replace damaged and malfunctioning controls and equipment.
- E. Air terminal unit will be considered defective if it does not pass tests and inspections.
- F. Prepare test and inspection reports.

3.6 STARTUP SERVICE

- A. Perform startup service.

1. Complete installation and startup checks according to manufacturer's written instructions.
2. Verify that inlet duct connections are as recommended by air terminal unit manufacturer to achieve proper performance.
3. Verify that controls and control enclosure are accessible.
4. Verify that control connections are complete.
5. Verify that nameplate and identification tag are visible.
6. Verify that controls respond to inputs as specified.

3.7 VENTURI SYSTEM START UP

- A. System start-up shall be provided by a factory-authorized representative of the venturi air valves manufacturer. System start-up shall provide electronic verification of all airflow (fume hood exhaust, supply, make-up, general exhaust or return), system programming and integration to BAS (when applicable). Successful bidders shall have at least three local certified factory-authorized technicians available for start-up and service.
- B. Provide factory start up and provisions for labor to support calibration of Venturi Air Valves along with TAB contractor. TAB Contractor will be responsible for final verification and reporting of all airflows.

3.8 DEMONSTRATION

- A. Train Owner's maintenance personnel to adjust, operate, and maintain air terminal units.

END OF SECTION 233600

SECTION 233713 - DIFFUSERS, REGISTERS, AND GRILLES

PART 1 - GENERAL

1.1 RELATED DOCUMENTS

- A. Drawings and general provisions of the Contract, including General and Supplementary Conditions and Division 01 Specification Sections, apply to this Section.

1.2 SUMMARY

- A. Section Includes:

1. Round ceiling diffusers.
2. Rectangular and square ceiling diffusers.
3. Perforated diffusers.
4. Louver face diffusers.
5. Linear bar diffusers.
6. Linear slot diffusers.
7. Adjustable bar registers and grilles.
8. Fixed registers and grilles.

- B. Related Sections:

1. Division 08 Section "Louvers and Vents" for fixed and adjustable louvers and wall vents, whether or not they are connected to ducts.
2. Division 23 Section "Air Duct Accessories" for fire and smoke dampers and volume-control dampers not integral to diffusers, registers, and grilles.

1.3 SUBMITTALS

- A. Product Data: For each type of product indicated, include the following:

1. Data Sheet: Indicate materials of construction, finish, and mounting details; and performance data including throw and drop, static-pressure drop, and noise ratings.
2. Diffuser, Register, and Grille Schedule: Indicate drawing designation, room location, quantity, model number, size, and accessories furnished.

- B. Samples for Initial Selection: For diffusers, registers, and grilles with factory-applied color finishes.

- C. Samples for Verification: For diffusers, registers, and grilles, in manufacturer's standard sizes to verify color selected.

- D. Coordination Drawings: Reflected ceiling plans, drawn to scale, on which the following items are shown and coordinated with each other, using input from Installers of the items involved:

1. Ceiling suspension assembly members.
 2. Method of attaching hangers to building structure.
 3. Size and location of initial access modules for acoustical tile.
 4. Ceiling-mounted items including lighting fixtures, diffusers, grilles, speakers, sprinklers, access panels, and special moldings.
 5. Duct access panels.
- E. Source quality-control reports.

PART 2 - PRODUCTS

2.1 CEILING DIFFUSERS

- A. Round Ceiling Diffuser:
1. Basis-of-Design Product: Subject to compliance with requirements, provide product indicated on Drawings or comparable product by one of the following:
 - a. Carnes.
 - b. Hart & Cooley Inc.
 - c. METALAIRE, Inc.
 - d. Price Industries.
 - e. Titus.
 - f. Tuttle & Bailey.
 2. Devices shall be specifically designed for variable-air-volume flows.
 3. Material: Aluminum.
 4. Finish: Baked enamel, white.
 5. Face Style: Three cone
 6. Mounting: Duct connection.
 7. Pattern: Fully adjustable.
 8. Dampers: Radial opposed blade.
- B. Rectangular and Square Ceiling Diffusers:
1. Basis-of-Design Product: Subject to compliance with requirements, provide product indicated on Drawings or comparable product by one of the following:
 - a. Carnes.
 - b. Hart & Cooley Inc.
 - c. Krueger.
 - d. METALAIRE, Inc.
 - e. Price Industries.
 - f. Titus.
 - g. Tuttle & Bailey.
 2. Devices shall be specifically designed for variable-air-volume flows.
 3. Material: Aluminum.
 4. Finish: Baked enamel, white.
 5. Face Size: As indicated.
 6. Face Style: Three cone.
 7. Mounting: Surface T-bar.

8. Pattern: Fixed.
 9. Dampers: Radial opposed blade
- C. Perforated Diffuser:
1. Basis-of-Design Product: Subject to compliance with requirements, provide product indicated on Drawings or comparable product by one of the following:
 - a. Air Research Diffuser Products, Inc.
 - b. Carnes.
 - c. Hart & Cooley Inc.
 - d. Krueger.
 - e. METALAIRE, Inc.
 - f. Price Industries.
 - g. Titus.
 - h. Tuttle & Bailey.
 - i. Warren Technology.
 2. Devices shall be specifically designed for variable-air-volume flows.
 3. Material: Steel back pan and pattern controllers, with aluminum face.
 4. Finish: Baked enamel, white.
 5. Face Size: 24 by 24 inches.
 6. Duct Inlet: Round.
 7. Face Style: Flush.
 8. Mounting: T-bar.
 9. Pattern Controller: Four louvered deflector patches.
 10. Dampers: Radial opposed blade.
- D. Louver Face Diffuser:
1. Basis-of-Design Product: Subject to compliance with requirements, provide product indicated on Drawings or comparable product by one of the following:
 - a. Carnes.
 - b. METALAIRE, Inc.
 - c. Price Industries.
 - d. Titus.
 - e. Tuttle & Bailey.
 2. Devices shall be specifically designed for variable-air-volume flows.
 3. Material: Aluminum.
 4. Finish: Baked enamel, white
 5. Face Size: As Indicated
 6. Mounting: T-bar.
 7. Pattern: Adjustable core style.
 8. Dampers: Radial opposed blade.
 9. Accessories:
 - a. Adjustable pattern vanes.
 - b. Throw reducing vanes.
 - c. Equalizing grid.

2.2 CEILING LINEAR SLOT OUTLETS

A. Linear Bar Diffuser:

1. Basis-of-Design Product: Subject to compliance with requirements, provide product indicated on Drawings or comparable product by one of the following:
 - a. Air Research Diffuser Products, Inc.
 - b. Carnes.
 - c. Dayus Register & Grille Inc.
 - d. Hart & Cooley Inc.
 - e. Krueger.
 - f. METALAIRE, Inc.
 - g. Price Industries.
 - h. Titus.
 - i. Tuttle & Bailey.
2. Devices shall be specifically designed for variable-air-volume flows.
3. Material: Aluminum.
4. Finish: Baked enamel, white
5. Narrow Core Spacing Arrangement: 1/8-inch thick blades spaced 1/4 inch apart, 15-degree deflection.
6. Wide Core Spacing Arrangement: 1/8-inch thick blades spaced 1/2 inch apart, 15-degree deflection.
7. Wide Core Spacing Arrangement: 3/16-inch thick blades spaced 1/2 inch apart, 1530-degree deflection.
8. Pencil-Proof Core Spacing Arrangement: 3/16-inch thick blades spaced 7/16 inch apart, zero 15 30-degree deflection.
9. Two-Way Deflection Vanes: Extruded construction fixed louvers with removable core.
10. Frame: 1-1/4 inches.
11. Mounting Frame: as indicated.
12. Mounting: Concealed bracket.
13. Damper Type: Adjustable opposed-blade assembly.

B. Linear Slot Diffuser:

1. Basis-of-Design Product: Subject to compliance with requirements, provide product indicated on Drawings or comparable product by one of the following:
 - a. Air Research Diffuser Products, Inc.
 - b. Carnes.
 - c. Hart & Cooley Inc.
 - d. Krueger.
 - e. METALAIRE, Inc.
 - f. Price Industries.
 - g. Titus.
 - h. Tuttle & Bailey.
2. Devices shall be specifically designed for variable-air-volume flows.
3. Material - Shell: Steel insulated.

4. Material - Pattern Controller and Tees: Aluminum.
5. Finish - Face and Shell: Baked enamel, black.
6. Finish - Pattern Controller: Baked enamel, black.
7. Finish - Tees: Baked enamel, white.
8. Slot Width: As indicated.
9. Number of Slots: As indicated.
10. Accessories: T-bar slot.

2.3 REGISTERS AND GRILLES

A. Adjustable Bar Register:

1. Basis-of-Design Product: Subject to compliance with requirements, provide product indicated on Drawings or comparable product by one of the following:
 - a. Carnes.
 - b. Dayus Register & Grille Inc.
 - c. Hart & Cooley Inc.
 - d. Krueger.
 - e. METALAIRE, Inc.
 - f. Price Industries.
 - g. Titus.
 - h. Tuttle & Bailey.
2. Material: Aluminum.
3. Finish: Baked enamel, white.
4. Face Blade Arrangement: Horizontal spaced 3/4 inch apart.
5. Core Construction: Integral.
6. Rear-Blade Arrangement: Vertical spaced 3/4 inch apart.
7. Frame: 1 inch wide.
8. Mounting Frame: Filter.
9. Mounting: as indicated.
10. Damper Type: Adjustable opposed blade.
11. Accessories:
 - a. Rear-blade gang operator.
 - b. Filter access from front.
 - c. Filter.

B. Adjustable Bar Grille:

1. Basis-of-Design Product: Subject to compliance with requirements, provide product indicated on Drawings or comparable product by one of the following:
 - a. Carnes.
 - b. Dayus Register & Grille Inc.
 - c. Hart & Cooley Inc.
 - d. Krueger.
 - e. METALAIRE, Inc.
 - f. Nailor Industries Inc.
 - g. Price Industries.
 - h. Titus.
 - i. Tuttle & Bailey.

2. Material: Aluminum.
3. Finish: Baked enamel, white.
4. Face Blade Arrangement: Horizontal spaced 3/4 inch apart.
5. Core Construction: Integral.
6. Rear-Blade Arrangement: Vertical spaced 3/4 inch apart.
7. Frame: 1 inch wide.
8. Mounting Frame: Filter access from front.
9. Mounting: As indicated.

C. Fixed Face Register:

1. Basis-of-Design Product: Subject to compliance with requirements, provide product indicated on Drawings or comparable product by one of the following:
 - a. Carnes.
 - b. Dayus Register & Grille Inc.
 - c. Hart & Cooley Inc.
 - d. Krueger.
 - e. Price Industries.
 - f. Titus.
 - g. Tuttle & Bailey.
2. Material: Aluminum.
3. Finish: Baked enamel, white.
4. Face Arrangement: As indicated.
5. Core Construction: Integral.
6. Frame: 1 inch wide.
7. Mounting Frame: As indicated.
8. Mounting: Countersunk screw.
9. Damper Type: Adjustable opposed blade

D. Fixed Face Grille:

1. Basis-of-Design Product: Subject to compliance with requirements, provide product indicated on Drawings or comparable product by one of the following:
 - a. Carnes.
 - b. Dayus Register & Grille Inc.
 - c. Hart & Cooley Inc.
 - d. Krueger.
 - e. Price Industries.
 - f. Titus.
 - g. Tuttle & Bailey.
2. Material: Aluminum
3. Finish: Baked enamel, white.
4. Face Arrangement: as indicated.
5. Core Construction: Integral.
6. Frame: 1 inch wide.
7. Mounting Frame: as indicated.
8. Mounting: [Countersunk screw] [Concealed] [Lay in].

E. Proceed with installation only after unsatisfactory conditions have been corrected.

2.4 INSTALLATION

- A. Install diffusers, registers, and grilles level and plumb.
- B. Ceiling-Mounted Outlets and Inlets: Drawings indicate general arrangement of ducts, fittings, and accessories. Air outlet and inlet locations have been indicated to achieve design requirements for air volume, noise criteria, airflow pattern, throw, and pressure drop. Make final locations where indicated, as much as practical. For units installed in lay-in ceiling panels, locate units in the center of panel. Where architectural features or other items conflict with installation, notify Architect for a determination of final location.
- C. Install diffusers, registers, and grilles with airtight connections to ducts and to allow service and maintenance of dampers, air extractors, and fire dampers.

2.5 ADJUSTING

- A. After installation, adjust diffusers, registers, and grilles to air patterns indicated, or as directed, before starting air balancing.

END OF SECTION 233713

SECTION 235700 - HEAT EXCHANGERS FOR HVAC

PART 1 - GENERAL

1.1 RELATED DOCUMENTS

- A. Drawings and general provisions of the Contract, including General and Supplementary Conditions and Division 01 Specification Sections, apply to this Section.

1.2 SUMMARY

- A. Section includes shell-and-tube, brazed-plate and gasketed-plate heat exchangers.

1.3 DEFINITIONS

- A. TEMA: Tubular Exchanger Manufacturers Association.

1.4 ACTION SUBMITTALS

- A. Product Data: For each type of product.
 - 1. Include rated capacities, operating characteristics, and furnished specialties and accessories.
 - 2. Performance and capacity rating shall conform with provisions of AHRI 400.
 - 3. Total GSF of heat transfer area heat exchanger shall be indicated on product submittal along with performance requirements.
- B. Shop Drawings: Signed and sealed by a qualified professional engineer. Detail equipment assemblies and indicate dimensions, weights, loads, required clearances, method of field assembly, components, and location and size of each field connection.
 - 1. Design Calculations: Calculate requirements for selecting seismic restraints and for designing bases.
 - 2. Base Details: Detail fabrication, including anchorages and attachments to structure and to supported equipment.

1.5 INFORMATIONAL SUBMITTALS

- A. Coordination Drawings: Equipment room plan or BIM model, drawn to scale, showing the items described in this Section, and coordinated with all building trades.
- B. Product Certificates: For each type of shell-and-tube heat exchanger. Documentation that shell-and-tube heat exchangers comply with "TEMA Standards."

- C. Source quality-control reports.
- D. Field quality-control reports.
- E. Sample Warranty: For manufacturer's warranty.

1.6 CLOSEOUT SUBMITTALS

- A. Operation and Maintenance Data: For heat exchangers to include in emergency, operation, and maintenance manuals.

1.7 WARRANTY

- A. Special Warranty: Manufacturer agrees to repair or replace components of heat exchangers that fail in materials or workmanship within specified warranty period.
 - 1. Failures include, but are not limited to, the following:
 - a. Structural failures, including heat exchanger, storage tank, and supports.
 - b. Faulty operation of controls.
 - c. Deterioration of metals, metal finishes, and other materials beyond normal use.
 - 2. Warranty Periods: From date of Substantial Completion.
 - a. Shell-and-Tube Heat Exchangers:
 - 1) Tube Coil: Two years.
 - 2) Other Components: Two years.
 - b. Plate Heat Exchangers:
 - 1) Brazed-Plate Type: Two years.
 - 2) Gasketed-Plate Type; Two years.

PART 2 - PRODUCTS

2.1 SHELL-AND-TUBE HEAT EXCHANGERS

- A. Manufactures:
 - 1. Alfa-Laval
 - 2. Bell and Gossett
- B. Description: Packaged assembly of tank, heat-exchanger coils, and specialties.
- C. Construction:

1. Fabricate and label heat exchangers to comply with ASME Boiler and Pressure Vessel Code, Section VIII, "Pressure Vessels," Division 1.
 2. Fabricate and label shell-and-tube heat exchangers to comply with "TEMA Standards."
- D. Configuration: U-tube with removable bundle.
- E. Shell Materials: Steel.
- F. Head:
1. Materials: Fabricated steel with removable cover.
 2. Flanged and bolted to shell.
- G. Tube: Cupronickel tubes.
1. Tube diameter is determined by manufacturer based on service.
- H. Tubesheet Materials: Steel Stainless Steel.
- I. Baffles: Stainless steel.
- J. Piping Connections: Factory fabricated of materials compatible with heat-exchanger shell. Attach tappings to shell before testing and labeling.
1. Piped for counterflow heat transfer.
 2. NPS 2 and Smaller: Threaded ends in accordance with ASME B1.20.1.
 3. NPS 2-1/2 and Larger: Flanged ends in accordance with ASME B16.5 for steel and stainless steel flanges and in accordance with ASME B16.24 for copper and copper-alloy flanges.
- K. Support Saddles:
1. Fabricated of material similar to shell.
 2. Fabricate foot mount with provision for anchoring to support.
- L. Capacities and Characteristics:
1. General:
 - a. Refer to Schedule:
 2. Shell Side:
 - a. Refer to Schedule:
 3. Tube Side:
 - a. Refer to Schedule:
- 2.2 GASKETED-PLATE HEAT EXCHANGERS
- A. Manufactures:
1. Alfa-Laval
 2. Bell and Gossett

- B. Configuration: Freestanding assembly, consisting of frame support, top and bottom carrying and guide bars, fixed and movable end plates, tie rods, individually removable plates, and one-piece gaskets. Floor-mounted heat exchangers must have integral legs with mounting feet.
- C. Construction: Fabricate and label heat exchangers to comply with ASME Boiler and Pressure Vessel Code, Section VIII, "Pressure Vessels," Division 1.
- D. Frame:
 - 1. Capacity to accommodate 20 percent additional plates.
 - 2. Painted carbon steel with provisions for anchoring to support.
- E. Top and Bottom Carrying and Guide Bars: Painted carbon steel, aluminum, or stainless steel.
 - 1. Fabricate attachment of heat-exchanger support bars and guide bars with reinforcement strong enough to resist heat-exchanger movement during seismic event when heat-exchanger support bars and guide bars are anchored to building structure.
- F. End-Plate Material: Painted carbon steel.
- G. Tie Rods and Nuts: Steel or stainless steel.
- H. Plate Material: 0.031 inch thick before stamping; Type 316 stainless steel.
- I. Gasket Materials: EPDM rubber.
 - 1. Glue: Chlorine free.
- J. Piping Connections: Factory fabricated of materials compatible with heat-exchanger shell. Attach tappings to shell before testing and labeling.
 - 1. Piped for counter flow heat transfer.
 - 2. NPS 2 and Smaller: Threaded ends in accordance with ASME B1.20.1.
 - 3. NPS 2-1/2 and Larger: Flanged ends in accordance with ASME B16.5 for steel and stainless steel flanges and in accordance with ASME B16.24 for copper and copper-alloy flanges.
- K. Enclose plates in solid stainless steel removable shroud.
- L. Capacities and Characteristics:
 - 1. General:
 - a. Refer to Schedule:
 - 2. Hot Side:
 - a. Refer to Schedule:
 - 3. Cold Side:
 - a. Refer to Schedule:

2.3 BRAZED-PLATE HEAT EXCHANGERS

- A. Manufactures:
 - 1. Alfa-Laval
 - 2. Bell and Gossett
- B. Configuration: Brazed assembly, consisting of embossed or pressed stainless steel plates brazed together and two end plates, one with threaded nozzles and one with pattern-embossed plates. Floor-mounted heat exchangers must have factory-furnished integral legs with mounting feet.
- C. Construction: Fabricate and label heat exchangers to comply with ASME Boiler and Pressure Vessel Code, Section VIII, "Pressure Vessels," Division 1.
- D. End-Plate Material: Type 316 stainless steel.
- E. Threaded Nozzles: Type 316 stainless steel.
- F. Plate Material: Type 316 stainless steel.
- G. Brazing Material: Copper or nickel.
- H. Capacities and Characteristics:
 - 1. General:
 - a. Refer to Schedule:
 - 2. Hot Side:
 - a. Refer to Schedule
 - 3. Cold Side:
 - a. Refer to Schedule

2.4 ACCESSORIES

- A. Hangers and Supports:
 - 1. Custom-built steel supports and saddles for mounting on floor or structural steel.
 - a. Minimum Number of Saddles: 2.
 - 2. Supports and saddles to ensure both horizontal and vertical support of heat exchanger. Comply with requirements in Section 230529 "Hangers and Supports for HVAC Piping and Equipment."
- B. Shroud: Aluminum sheet.
- C. Miscellaneous Components for Hot-Water Unit: Control valve, valves, thermometers, and piping. Include components fitted for electronic control.
- D. Miscellaneous Components for Steam Unit: Strainers, steam-control valve, steam trap, valves, pressure gauge, thermometers, and piping. Include components fitted for electronic control.

E. Pressure-Relief Valves: Cast iron, ASME rated and stamped.

1. Pressure-relief valve setting: 150 PSIG

2.5 SOURCE QUALITY CONTROL

A. Factory Tests: Test and inspect heat exchangers in accordance with ASME Boiler and Pressure Vessel Code, Section VIII, "Pressure Vessels," Division 1. Affix ASME International label.

B. Hydrostatically test heat exchangers to minimum of one and one-half times pressure rating before shipment.

C. Heat exchangers will be considered defective if they do not pass tests and inspections.

D. Prepare test and inspection reports.

PART 3 - EXECUTION

3.1 EXAMINATION

A. Examine areas for compliance with requirements for installation tolerances and for structural rigidity, strength, anchors, and other conditions affecting performance of heat exchangers.

B. Examine roughing-in for heat-exchanger piping to verify actual locations of piping connections before equipment installation.

C. Proceed with installation only after unsatisfactory conditions have been corrected.

3.2 INSTALLATION OF HEAT EXCHANGER, GENERAL

A. Equipment Mounting:

1. Install floor-mounted heat exchangers on cast-in-place concrete equipment bases. Install all heat exchangers level and plumb in accordance with manufacturer's recommendations. Install floor-mounted and wall-hung steam heat exchangers at sufficient height, using sufficient length supports, to achieve required steam and condensate pipe pitch. Comply with requirements for equipment bases and foundations specified in Section 033000 "Cast-in-Place Concrete."

2. Comply with requirements for vibration isolation and seismic control devices specified in Section 230548 "Vibration and Seismic Controls for HVAC."

3.3 INSTALLATION OF SHELL-AND-TUBE HEAT EXCHANGER

A. Install heat exchangers on saddle supports.

- B. Heat-Exchanger Supports: Mount heat exchanger on steel saddles and supports specifically designed for each heat exchanger.
- C. Fabricate attachment of saddle supports to pressure vessel with reinforcement strong enough to resist heat-exchanger movement during seismic event when heat-exchanger saddles are anchored to building structure.

3.4 INSTALLATION OF GASKETED-PLATE HEAT EXCHANGER

- A. Install wall-mounted gasketed-plate heat exchanger on custom-designed wall supports anchored to structure as indicated on Drawings.
- B. Install floor-mounted gasketed-plate heat exchangers on cast-in-place concrete equipment base, and fasten legs to base.
- C. Install metal shroud over installed gasketed-plate heat exchanger in accordance with manufacturer's written instructions.

3.5 INSTALLATION OF BRAZED-PLATE HEAT EXCHANGER

- A. Install wall-mounted brazed-plate heat exchanger on custom-designed wall supports anchored to structure as indicated on Drawings.
- B. Install floor-mounted brazed-plate heat exchangers on cast-in-place concrete equipment base and fasten legs to base.

3.6 PIPING CONNECTIONS

- A. Comply with requirements for piping specified in Section 232113 "Hydronic Piping" and Section 232116 "Hydronic Piping Specialties." Drawings indicate general arrangement of piping, fittings, and specialties.
- B. Comply with requirements for steam and condensate piping specified in Section 232213 "Steam and Condensate Heating Piping" and Section 232216 "Steam and Condensate Heating Piping Specialties."
- C. Maintain manufacturer's recommended clearances for tube removal, service, and maintenance.
- D. Install piping adjacent to heat exchangers to allow space for service and maintenance of heat exchangers. Arrange piping for easy removal of heat exchangers.
- E. Install shutoff valves at heat-exchanger inlet and outlet connections.
- F. Install pressure-relief valves on heat-exchanger shells where a connection has been provided on shell. When no shell pressure-relief valve connection has been provided, install pressure-relief valve on shell outlet piping before any isolation valves.
- G. Install pressure-relief valves on heat-exchanger tube outlet piping before any isolation valves.

- H. Pipe pressure-relief valves, full size of valve connection, to floor drain.
- I. Install vacuum breaker at heat-exchanger steam inlet connection.
- J. Install hose end valve to drain shell.
- K. Install thermometer on each heat-exchanger fluid inlet and outlet piping. Comply with requirements for thermometers specified in Section 230519 "Meters and Gages for HVAC Piping."
- L. Install pressure gauges on each heat-exchanger fluid inlet and outlet piping and steam inlet piping. Comply with requirements for pressure gauges specified in Section 230519 "Meters and Gauges for HVAC Piping."

3.7 CLEANING

- A. After completing system installation, including outlet fitting and devices, inspect exposed finish. Remove burrs, dirt, and construction debris, and repair damaged finishes.
- B. Isolate heat exchangers from piping before flushing piping. If a valve is used to isolate equipment, its closure shall be capable of sealing against test pressure without damage to valve. Install blind flanges in flanged joints to isolate equipment.
- C. Flush heat-exchanger piping systems with clean water; then remove and clean or replace strainer screens before reopening flow to heat exchangers.

3.8 FIELD QUALITY CONTROL

- A. Testing Agency, Owner: Owner will engage a qualified testing agency to perform tests and inspections.
- B. Testing Agency, Contractor: Engage a qualified testing agency to perform tests and inspections.
- C. Manufacturer's Field Service: Engage a factory-authorized service representative to test and inspect components, assemblies, and equipment installations, including connections.
- D. Perform tests and inspections:
- E. Tests and Inspections:
 - 1. Leak Test: After installation, charge system and test for leaks. Repair leaks and retest until no leaks exist.
 - 2. Test and adjust controls and safeties. Replace damaged and malfunctioning controls and equipment.
- F. Heat exchanger will be considered defective if it does not pass tests and inspections.
- G. Prepare test and inspection reports.

3.9 DEMONSTRATION

- A. Train Owner's maintenance personnel to adjust, operate, and maintain heat exchangers.

END OF SECTION 235700

SECTION 238113 - PACKAGED TERMINAL AIR-CONDITIONERS

PART 1 - GENERAL

1.1 RELATED DOCUMENTS

- A. Drawings and general provisions of the Contract, including General and Supplementary Conditions and Division 01 Specification Sections, apply to this Section.

1.2 SUMMARY

- A. Section includes packaged terminal air conditioners and their accessories and controls, in the following configurations:
 - 1. Through-the-wall and freestanding air conditioners.
 - 2. Cooling-only units.
 - 3. Heat-pump units.
 - 4. Cooling units with electric heat.
 - 5. Cooling units with hydronic heat.

1.3 SUBMITTALS

- A. Product Data: For each type of product indicated. Include rated capacities, operating characteristics, furnished specialties, electrical characteristics, and accessories.
- B. Shop Drawings: For packaged terminal air conditioners. Include plans, elevations, sections, details for wall penetrations and attachments to other work.
 - 1. Detail equipment assemblies and indicate dimensions, weights, loads, required clearances, method of field assembly, components, and location and size of each field connection.
 - 2. Wiring Diagrams: For power, signal, and control wiring.
- C. Color Samples: For unit cabinet, discharge grille, and exterior louver, and for each color and texture specified.
- D. Product Test Reports: Based on evaluation of comprehensive tests performed by manufacturer and witnessed by a qualified testing agency, for packaged terminal air conditioners.
- E. Field quality-control reports.
- F. Operation and Maintenance Data: For packaged terminal air conditioners to include in emergency, operation, and maintenance manuals.
- G. Warranty: Sample of special warranty.

1.4 QUALITY ASSURANCE

- A. Electrical Components, Devices, and Accessories: Listed and labeled as defined in NFPA 70, by a qualified testing agency, and marked for intended location and application.
- B. ASHRAE Compliance: Applicable requirements in ASHRAE 62.1-2004, Section 4 - "Outdoor Air Quality," Section 5 - "Systems and Equipment," Section 6 - "Ventilation Rate Procedures," and Section 7 - "Construction and Startup."
- C. ASHRAE/IESNA Compliance: Applicable requirements in ASHRAE/IESNA 90.1-2004.

1.5 COORDINATION

- A. Coordinate layout and installation of packaged terminal air conditioners and wall construction with other construction that penetrates walls or is supported by them.

1.6 WARRANTY

- A. Special Warranty: Manufacturer's standard form in which manufacturer agrees to repair or replace components of packaged terminal air conditioners that fail in materials or workmanship within specified warranty period.
 - 1. Warranty Period for Sealed Refrigeration System: Manufacturer's standard, but not less than five years from date of Substantial Completion, including components and labor.
 - 2. Warranty Period for Nonsealed System Parts: Manufacturer's standard, but not less than five years from date of Substantial Completion, including only components and excluding labor.
 - 3. Warranty Period for Heat Exchangers: Manufacturer's standard, but not less than five years from date of Substantial Completion.

PART 2 - PRODUCTS

2.1 MANUFACTURERS

- A. Manufacturers: Subject to compliance with requirements, available manufacturers offering products that may be incorporated into the Work include, but are not limited to, the following:
 - 1. Carrier Corporation; a United Technologies company.
 - 2. ClimateMaster, Inc.
 - 3. Friedrich Air Conditioning Co. (Thru wall applications).
 - 4. Daikin
 - 5. Trane; a business of American Standard Companies.
 - 6. Envirotech

2.2 MANUFACTURED UNITS

- A. Description: Factory-assembled and -tested, self-contained, packaged terminal air conditioner with room cabinet, electric refrigeration system, heating, and temperature controls; fully charged with refrigerant and filled with oil; with hard wired chassis.

2.3 CHASSIS

- A. Cabinet: 0.052-inch- thick steel with removable front panel with concealed latches.
1. Mounting: Wall with wall sleeve.
 2. Discharge Grille: Extruded-aluminum discharge grille.
 3. Louvers: Extruded aluminum with enamel finish Stamped aluminum with clear-anodized finish Stamped steel with enamel finish; white color.
 4. Finish: Baked enamel.
 5. Access Door: Hinged door in top of cabinet for access to controls.
 6. Cabinet Extension: Matching cabinet in construction and finish, allowing diversion of airflow to adjoining room; with grille.
 7. Finish of Interior Surfaces: Surfaces in contact with the airstream shall comply with requirements in ASHRAE 62.1-2004.
 8. Subbase: Enameled steel with adjustable leveling feet and adjustable end plates.
 9. Wall Sleeves: Galvanized steel with polyester finish.
- B. Refrigeration System: Direct-expansion indoor coil with capillary restrictor; and hermetically sealed scroll compressor with vibration isolation and overload protection.
1. Indoor and Outdoor Coils: Seamless copper tubes mechanically expanded into aluminum fins with capillary tube distributor on indoor coil.
 2. Accumulator.
 3. Constant-pressure expansion valve.
 4. Reversing valve.
 5. Charge: R-407C.
- C. Indoor Fan: Forward curved, centrifugal; with motor and positive-pressure ventilation damper with concealed manual electric operator.
- D. Filters: Washable polyurethane in molded plastic frame.
- E. Condensate Drain: Drain pan to direct condensate to outdoor coil for re-evaporation or piping to direct condensate to building waste and vent piping.
1. Comply with ASHRAE 62.1-2004 for drain pan construction and connections.
- F. Outdoor Fan: Forward curved, centrifugal or type driven by indoor fan motor.
1. Indoor Fan Motors: Two speed; comply with NEMA designation, temperature rating, service factor, enclosure type, and efficiency requirements for motors specified in Division 23 Section "Common Motor Requirements for HVAC Equipment."

- a. Fan Motors: Permanently lubricated split capacitor.
- b. Motor Sizes: Minimum size as indicated. If not indicated, large enough so driven load will not require motor to operate in service factor range above 1.0.
- c. Controllers, Electrical Devices, and Wiring: Comply with requirements for electrical devices and connections specified in Division 26 Sections.

2.4 HEATING

- A. Electric-Resistance Heating Coil: Nickel-chromium-wire, electric-resistance heating elements with contactor and high-temperature-limit switch.
- B. Hot-Water Heating Coil: Seamless copper tubes mechanically expanded into aluminum fins with two-way modulating control valve and air vent.

2.5 CONTROLS

- A. Control Module: Unit-mounted digital panel with touchpad temperature control and with touchpad for heating, cooling, and fan operation. Include the following features:
 1. Low Ambient Lockout Control: Prevents cooling-cycle operation below 40 deg F outdoor air temperature.
 2. Heat-Pump Ambient Control: Field-adjustable switch changes to heat-pump heating operation above 40 deg F and to supplemental heating below plus 25 deg F.
 3. Temperature-Limit Control: Prevents occupant from exceeding preset setback or setup temperature.
 4. Building Automation System Interface: Allows remote on-off control with setback temperature control.
 5. Reverse-Cycle Defrost: Solid-state sensor monitors frost buildup on outdoor coil and reverses unit to melt frost.
- B. Remote Control: Standard unit-mounted controls with remote-mounted, low-voltage adjustable thermostat with heat anticipator, heat-off-cool-autoswitch, and on-auto fan switch.
- C. Outdoor Air Motorized intake damper. Open intake when unit indoor air fan runs.

2.6 CAPACITIES AND CHARACTERISTICS

- A. Airflow: As indicated.
- B. Outdoor Air-Intake Rate: As indicated.
- C. Cooling Capacity: As indicated
- D. Heating Capacity: As indicated.

2.7 SOURCE QUALITY CONTROL

- A. Sound-Power Level Ratings: Factory test to comply with ARI 300, "Sound Rating and Sound Transmission Loss of Packaged Terminal Equipment."
- B. Unit Performance Ratings: Factory test to comply with ARI 310/380/CSA C744, "Packaged Terminal Air-Conditioners and Heat Pumps."

PART 3 - EXECUTION

3.1 INSTALLATION

- A. Install units level and plumb, maintaining manufacturer's recommended clearances and tolerances.
- B. Install wall sleeves in finished wall assembly; seal and weatherproof. Joint-sealant materials and applications are specified in Division 07 Section "Joint Sealants."
- C. Install and anchor wall sleeves to withstand, without damage to equipment and structure, seismic forces required by building code.

3.2 CONNECTIONS

- A. Comply with requirements for piping specified in Division 23 Section "Hydronic Piping." Drawings indicate general arrangement of piping, fittings, and specialties.
- B. Install piping adjacent to machine to allow service and maintenance.

3.3 FIELD QUALITY CONTROL

- A. Manufacturer's Field Service: Engage a factory-authorized service representative to inspect, test, and adjust components, assemblies, and equipment installations, including connections.
- B. Perform tests and inspections.
 - 1. Manufacturer's Field Service: Engage a factory-authorized service representative to inspect components, assemblies, and equipment installations, including connections, and to assist in testing.
- C. Tests and Inspections:
 - 1. Inspect for and remove shipping bolts, blocks, and tie-down straps.
 - 2. After installing packaged terminal air conditioners and after electrical circuitry has been energized, test for compliance with requirements.
 - 3. Operational Test: After electrical circuitry has been energized, start units to confirm proper motor rotation and unit operation.

4. Test and adjust controls and safeties. Replace damaged and malfunctioning controls and equipment.
- D. Packaged terminal air conditioners will be considered defective if they do not pass tests and inspections.
- E. Prepare test and inspection reports.

3.4 STARTUP SERVICE

- A. Engage a factory-authorized service representative to perform startup service.
- B. After installation, verify the following:
 1. Unit is level on base and is flashed in exterior wall.
 2. Unit casing has no visible damage.
 3. Compressor, air-cooled condenser coil, and fans have no visible damage.
 4. Labels are clearly visible.
 5. Controls are connected and operable.
 6. Shipping bolts, blocks, and tie-down straps are removed.
 7. Filters are installed and clean.
 8. Drain pan and drain line are installed correctly.
 9. Electrical wiring installation complies with manufacturer's submittal and installation requirements in Division 26 Sections "Low Voltage Electrical Power Conductors and Cables".
 10. Installation. Perform startup checks according to manufacturer's written instructions, including the following:
 - a. Lubricate bearings on fan.
 - b. Check fan-wheel rotation for correct direction without vibration and binding.
- C. After startup service and performance test, change filters.

3.5 ADJUSTING

- A. Adjust initial temperature set points.
- B. Set field-adjustable switches and circuit-breaker trip ranges as indicated.

3.6 DEMONSTRATION

- A. Owner's maintenance personnel to adjust, operate, and maintain packaged terminal air conditioners.

END OF SECTION 238113

SECTION 238119 - SELF-CONTAINED AIR-CONDITIONERS

PART 1 - GENERAL

1.1 RELATED DOCUMENTS

- A. Drawings and general provisions of the Contract, including General and Supplementary Conditions and Division 01 Specification Sections, apply to this Section.

1.2 SUMMARY

- A. Section includes packaged, air & water-cooled air-conditioning units with refrigerant compressors and controls intended for indoor installations.

1.3 SUBMITTALS

- A. Product Data: For each type of product indicated. Include rated capacities, operating characteristics, and furnished specialties and accessories.
- B. Shop Drawings: Include plans, elevations, sections, details, and attachments to other work.
 - 1. Detail equipment assemblies and indicate dimensions, weights, loads, required clearances, method of field assembly, components, and location and size of each field connection.
 - 2. Wiring Diagrams: For power, signal, and control wiring.
- C. Samples for Initial Selection: For units with factory-applied color finishes.
- D. Operation and Maintenance Data: For self-contained air conditioners to include in emergency, operation, and maintenance manuals.
- E. Warranty: Sample of special warranty.

1.4 QUALITY ASSURANCE

- A. Electrical Components, Devices, and Accessories: Listed and labeled as defined in NFPA 70, by a qualified testing agency, and marked for intended location and application.
- B. ARI Compliance:
 - 1. Applicable requirements in ARI 210/240.
 - 2. Applicable requirements in ARI 340/360.
 - 3. Applicable requirements in ARI 390.
- C. ASHRAE Compliance:

1. Fabricate and label refrigeration system to comply with ASHRAE 15, "Safety Standard for Refrigeration Systems."
2. ASHRAE Compliance: Applicable requirements in ASHRAE 62.1-2004, Section 4 - "Outdoor Air Quality," Section 5 - "Systems and Equipment," Section 6 - "Ventilation Rate Procedures," and Section 7 - "Construction and Startup."

D. ASHRAE/IESNA Compliance: Applicable requirements in ASHRAE/IESNA 90.1-2004.

1.5 COORDINATION

- A. Coordinate sizes and locations of concrete bases with actual equipment provided. Cast anchor-bolt inserts into bases. Concrete, reinforcement, and formwork are specified in Division 03 Section "Cast-in-Place Concrete."

1.6 RELATED SECTION

- A. Section 232300 – Refrigerant Piping.

1.7 WARRANTY

- A. Special Warranty: Manufacturer's standard form in which manufacturer agrees to repair or replace components of self-contained air conditioners that fail in materials or workmanship within specified warranty period.

1. Warranty Period:

- a. For Compressor: Fiveyear(s) from date of Substantial Completion.
- b. For Parts: Fiveyear(s) from date of Substantial Completion.
- c. For Labor: Fiveyear(s) from date of Substantial Completion.

1.8 EXTRA MATERIALS

- A. Furnish extra materials that match products installed and that are packaged with protective covering for storage and identified with labels describing contents.
1. Fan Belts: Onesetof belts for each unit.

PART 2 - PRODUCTS

2.1 MANUFACTURERS

- A. Manufacturers: Subject to compliance with requirements, provide products by one of the following:
1. Carrier Corporation; Home Comfort and HVAC Building & Industrial Systems.
 2. Daikin
 3. Trane Inc.

4. USA Coil & Air.
5. Whalen Company (The).

2.2 PACKAGED UNITS

- A. Description: Factory assembled, wired, and tested; and fully charged with refrigerant and oil.
- B. Configuration: Horizontal, ceiling mounted.
- C. Configuration: Vertical, floor mounted; horizontal discharge.
- D. Configuration: Horizontal, ceiling mounted and vertical, floor mounted; vertical discharge.
- E. Disconnect Switch: Factory mounted on cabinet.

2.3 CABINET

- A. Frame and Panels: Structural-steel frame with galvanized-steel panels and access doors or panels.
 1. Exterior-Surface Finish: Factory painted in color selected by Architect.
 2. Interior-Surface Finish: Surfaces in contact with the airstream shall comply with requirements in ASHRAE 62.1-2004.
- B. Insulation: 1-inch- thick, glass-fiber duct liner complying with ASTM C 1091 and having a microbial coating on cabinet interior and control panel. 1/2-inch- thick liner is acceptable for units smaller than 15 tons.
- C. Return-Air Opening: Rear, flange for duct connection.
- D. Corrosion-Resistant Treatment: Phenolic coating on unit interior and exterior.

2.4 SUPPLY-AIR FAN

- A. Fan Material: Galvanized steel.
- B. Configuration: Double-width, double-inlet, forward-curved centrifugal fan; statically and dynamically balanced. Discharge with flexible discharge collar.
- C. Drive: Belt, with fan mounted on permanently lubricated bearings.
- D. Fan Sheaves: Variable pitch, dynamically balanced, bored to fit shafts, and keyed for initial startup.
- E. Motor Sheave: Variable and adjustable pitch, dynamically balanced, and selected to achieve specified rpm when set at midposition.

- F. Belt Rating: As recommended by manufacturer or a minimum of one and one-half times nameplate rating of motor.
- G. Bearings: Grease lubricated with grease lines extended to exterior of unit with L-50 life at 200,000 hours.
- H. Variable Air Volume: Variable-frequency motor controller.
- I. Comply with NEMA designation, temperature rating, service factor, enclosure type, and efficiency requirements for motors specified in Division 23 Section "Common Motor Requirements for HVAC Equipment."
 - 1. Special Motor Features: Premium efficiency, as defined in Division 23 Section "Common Motor Requirements for HVAC Equipment."
- J. Isolation: Mount fan and motor on common subbase and mount assembly on spring isolators with minimum static deflection of 1 inch.
- K. Outdoor-Air-Intake Accessories:
 - 1. Barometric Outdoor-Air Damper: Adjustable-blade damper allowing induction of up to 25 percent outdoor air when evaporator fan is running.
 - 2. Motorized Outdoor-Air Damper: Motorized, two-position blade damper allowing induction of up to 25 percent outdoor air; with spring-return, low-voltage damper motor.
 - 3. Energy-Recovery Ventilator: Assembly of desiccant-coated, heat-recovery wheels and centrifugal exhaust fans to transfer approximately 67 percent of the difference between the sensible and latent heat of outdoor and exhaust air.
 - 4. Air-Side Economizer: Damper assembly allowing induction of up to 100 percent outdoor air to maintain a selected mixed-air temperature; and exhaust damper and spring-return, low-voltage, modulating damper motor with minimum position adjustment.

2.5 REFRIGERATION SYSTEM

- A. Compressor: Scroll type, hermetically sealed, 3600 rpm maximum, and resiliently mounted with positive lubrication and internal motor protection.
- B. Refrigerant Coils (Indoor and Outdoor for Air-Cooled Units): Seamless copper tubes expanded into aluminum fins.
 - 1. Corrosion-Resistant Treatment: Phenolic coating applied with multiple dips and baked.
 - 2. Refrigerant Circuits: A separate circuit for each compressor, with externally equalized thermal-expansion valve with adjustable superheat, filter dryer, sight glass, high-pressure relief valve, and charging valves.
 - 3. Mount coil assembly over stainless-steel drain pan complying with ASHRAE 62.1-2004 and having a condensate pump unit with integral float switch, check valve, pump-motor assembly, and condensate reservoir. Are required.
 - 4. Refrigerant: R-407C or R-410A.
 - 5. Expansion valve with replaceable thermostatic element.
 - 6. Refrigerant dryer.

7. High-pressure switch.
8. Low-pressure switch.
9. Thermostat for coil freeze-up protection during low ambient temperature operation or loss of air.
10. Low ambient temperature switch.
11. Brass service valves installed in discharge and liquid lines.

C. Water-Cooled Condenser:

1. Description: Factory assembled and tested; tube in tube coaxial type with water-regulating valve.
2. Tubing: Copper inner tube; refrigerant and water-side leak tested to 400 psig underwater.

D. Water-Side Economizer Section:

1. Description: Factory assembled and tested; consisting of water coil, modulating valves, controls, piping with cleanouts, and access panels.
2. Water Coil: Two rows, copper tube, with mechanically bonded aluminum fins spaced no closer than 0.1 inch, and copperheaders; leak tested to 300 psig underwater; and having a two-position control valve.

2.6 HEATING COIL

- A. Water Coil: Copper tube, with mechanically bonded aluminum fins spaced no closer than 0.1 inch; leak tested to 300 psig underwater; and having a two-position control valve.
- B. Electric Coil: Helical, nickel-chrome, resistance-wire heating elements with refractory ceramic support bushings; automatic-reset thermal cutout; built-in magnetic contactors; manual-reset thermal cutout; airflow-proving device; and one-time fuses in terminal box for overcurrent protection.

2.7 CONTROLS

- A. Control equipment and sequence of operation are specified in Division 23 Sections "Direct Digital Control (DDC) for HVAC."
- B. Control Package: Factory wired, including contactor, high- and low-pressure cutouts, internal-winding thermostat for compressor, control-circuit transformer, and noncycling reset relay.
- C. Time-Delay Relay: Five-minute delay to prevent compressor cycling.
- D. Adjustable Thermostat: Remote to control the following:
 1. Supply fan.
 2. Compressor.
 3. Condenser.
 4. Hot-water coil valve.

5. Electric heater.
- E. System Selector Switch: Off-heat-auto-cool.
- F. Fan Control Switch: Auto-on.
- G. Time Clock: Cycle unit on and off.
- H. Microprocessor Control Panel: Controls unit functions as standalone or network operation, including refrigeration and safety controls, with unit-mounted display, and the following:
 1. Supply fan.
 2. Supply-fan motor speed.
 3. Compressors.
 4. Air-cooled condenser.
 5. Cooling tower pump.
 6. Modulating, hot-water coil valve (Provide pressure independent control valve where PICV valves are installed in the existing facility or provided by CCMS Subcontractor for other equipment on project).
 7. Multistep, electric heater.
 8. Time-of-day control to cycle unit on and off.
 9. Night-heat, morning warm-up cycle.
 10. Economizer control.
 11. Panel-mounted control switch to operate unit in remote or local control mode or to stop or reset.
 12. Panel-mounted indication of the following:
 - a. Operating status.
 - b. System diagnostics and safety alarms.
 - c. Supply-air temperature set point.
 - d. Zone heating-temperature set point.
 - e. Supply-air pressure set point.
 - f. Economizer minimum position set point.
 - g. Supply-air-pressure, high-limit set point.
 - h. Monitor constant and variable motor loads.
 - i. Monitor variable-frequency drive operation.
 - j. Monitor economizer cycle.
 - k. Monitor cooling load.
 - l. Monitor air distribution static pressure and ventilation air volumes.

2.8 CAPACITIES AND CHARACTERISTICS

- A. Cooling Capacity: As indicated on drawings.
- B. Heating Capacity: As indicated on drawings.
- C. Auxiliary Electric Heat: As indicated on drawings.
- D. Supply-Air Fan: As indicated on drawings.

- E. Air-Cooled Condenser: As indicated on drawings.
- F. Water-Cooled Condenser: As indicated on drawings.
- G. Filters:
 - 1. Prefilters:
 - a. Type: Pleated disposable panel.
 - b. Thickness or Depth: 2 inches 4 inches.
 - c. Maximum or Rated Face Velocity: 4fpm.
 - d. Initial Resistance: 0.1inches wg >.
 - e. Recommended Final Resistance: 0.3inches wg.
 - f. Access Location: Side.
 - 2. Final Filter:
 - a. Type: Pleated disposable panel.
 - b. Thickness or Depth: 4 inches.
 - c. .
 - d. Maximum or Rated Face Velocity: 400 fpm.
 - e. Initial Resistance: 0.1 inches wg >.
 - f. Recommended Final Resistance: 0.5 inches wg.
 - g. Access Location: Side.
- H. Accessories:
 - 1. Manual outdoor-air damper.
 - 2. Motorized outdoor-air damper.
 - 3. Air-side economizer.
 - 4. Water-side economizer.
 - 5. Hot-gas bypass.
 - 6. Air Pressure Switch: Indicates when differential pressure exceeds set point representing dirty filters.
- I. Single-Point Electrical Characteristics: As indicated on drawings.

PART 3 - EXECUTION

3.1 INSTALLATION

- A. Install units level and plumb.
- B. Anchor units to structure.
- C. Install seismic restraints.

3.2 CONNECTIONS

- A. Piping installation requirements are specified in other Division 23 Sections. Drawings indicate general arrangement of piping, fittings, and specialties.
 - 1. Water Coil Connections: Comply with requirements in Division 23 Section "Hydronic Piping." Connect to supply and return coil with shutoff-duty valve and union or flange on the supply connection and with throttling-duty valve and union or flange on the return connection.
 - 2. Water-Cooled Condenser Connections: Comply with requirements in Division 23 Section "Hydronic Piping." Connect to supply and return with shutoff-duty valve and union or flange on the supply connection and with throttling-duty valve and union or flange on the return connection.
- B. Where installing piping adjacent to equipment, allow space for service and maintenance of equipment.
- C. Duct Connections: Duct installation requirements are specified in Division 23 Section "Metal Ducts." Drawings indicate the general arrangement of ducts. Connect supply and return ducts to self-contained air conditioners with flexible duct connectors. Flexible duct connectors are specified in Division 23 Section "Air Duct Accessories."

3.3 FIELD QUALITY CONTROL

- A. Manufacturer's Field Service: Engage a factory-authorized service representative to inspect, test, and adjust components, assemblies, and equipment installations, including connections.
- B. Perform tests and inspections.
 - 1. Manufacturer's Field Service: Engage a factory-authorized service representative to inspect components, assemblies, and equipment installations, including connections, and to assist in testing.
- C. Tests and Inspections:
 - 1. Operational Test: After electrical circuitry has been energized, start units to confirm proper motor rotation and unit operation, and inspect for refrigerant leaks.
 - 2. Test and adjust controls and safeties. Replace damaged and malfunctioning controls and equipment.
- D. Units will be considered defective if they do not pass tests and inspections.
- E. Prepare test and inspection reports.

3.4 STARTUP SERVICE

- A. Engage a factory-authorized service representative to perform startup service.

3.5 DEMONSTRATION

- A. Owner's maintenance personnel to adjust, operate, and maintain units.

END OF SECTION 238119

SECTION 238126 - SPLIT-SYSTEM AIR-CONDITIONERS

PART 1 - GENERAL

1.1 RELATED DOCUMENTS

- A. Drawings and general provisions of the Contract, including General and Supplementary Conditions and Division 01 Specification Sections, apply to this Section.

1.2 SUMMARY

- A. Section includes split-system air-conditioning and heat-pump units consisting of separate evaporator-fan and compressor-condenser components.

1.3 SUBMITTALS

- A. Product Data: For each type of product indicated. Include rated capacities, operating characteristics, and furnished specialties and accessories. Include performance data in terms of capacities, outlet velocities, static pressures, sound power characteristics, motor requirements, and electrical characteristics.
- B. Shop Drawings: Include plans, elevations, sections, details, and attachments to other work.
 - 1. Detail equipment assemblies and indicate dimensions, weights, loads, required clearances, method of field assembly, components, and location and size of each field connection.
 - 2. Wiring Diagrams: For power, signal, and control wiring.
- C. Samples for Initial Selection: For units with factory-applied color finishes.
- D. Field quality-control reports.
- E. Operation and Maintenance Data: For split-system air-conditioning units to include in emergency, operation, and maintenance manuals.
- F. Warranty: Sample of special warranty.

1.4 QUALITY ASSURANCE

- A. Electrical Components, Devices, and Accessories: Listed and labeled as defined in NFPA 70, by a qualified testing agency, and marked for intended location and application.
- B. ASHRAE Compliance:

1. Fabricate and label refrigeration system to comply with ASHRAE 15, "Safety Standard for Refrigeration Systems."
 2. ASHRAE Compliance: Applicable requirements in ASHRAE 62.1-2004, Section 4 - "Outdoor Air Quality," Section 5 - "Systems and Equipment," Section 6 - "Procedures," and Section 7 - "Construction and System Start-Up."
- C. ASHRAE/IESNA Compliance: Applicable requirements in ASHRAE/IESNA 90.1-2004.

1.5 COORDINATION

- A. Coordinate sizes and locations of concrete bases with actual equipment provided. Cast anchor-bolt inserts into bases. Concrete, reinforcement, and formwork are specified in Division 03 Section "Cast-in-Place Concrete."
- B. Coordinate sizes and locations of roof curbs, equipment supports, and roof penetrations with actual equipment provided.

1.6 WARRANTY

- A. Special Warranty: Manufacturer's standard form in which manufacturer agrees to repair or replace components of split-system air-conditioning units that fail in materials or workmanship within specified warranty period.
 1. Warranty Period:
 - a. For Compressor: Five year(s) from date of Substantial Completion.
 - b. For Parts: Five year(s) from date of Substantial Completion.
 - c. For Labor: Five year(s) from date of Substantial Completion.

PART 2 - PRODUCTS

2.1 MANUFACTURERS

- A. Basis-of-Design Product: Subject to compliance with requirements, provide product indicated on Drawings or comparable product by one of the following:
 1. Carrier Corporation; Home Comfort and HVAC Building & Industrial Systems.
 2. First Operations LP.
 3. Friedrich Air Conditioning Company.
 4. Mitsubishi Electric & Electronics USA, Inc.; HVAC Advanced Products Division.
 5. Mitsubishi Heavy Industries America, Inc.
 6. SANYO North America Corporation; SANYO Fisher Company.
 7. Trane; a business of American Standard companies.
 8. YORK; a Johnson Controls company.

2.2 INDOOR UNITS 5 TONS (18 kW) OR LESS

A. Concealed Evaporator-Fan Components:

1. Chassis: Galvanized steel with flanged edges, removable panels for servicing, and insulation on back of panel.
2. Insulation: Faced, glass-fiber duct liner.
3. Refrigerant Coil: Copper tube, with mechanically bonded aluminum fins and thermal-expansion valve. Comply with ARI 210/240.
4. Water Coil: Copper tube, with mechanically bonded aluminum fins spaced no closer than 0.1 inch; leak tested to 300 psig underwater; with a two-position control valve.
5. Electric Coil: Helical, nickel-chrome, resistance-wire heating elements; with refractory ceramic support bushings, automatic-reset thermal cutout, built-in magnetic contactors, manual-reset thermal cutout, airflow proving device, and one-time fuses in terminal box for overcurrent protection.
6. Fan: Forward-curved, double-width wheel of galvanized steel; directly connected to motor.
7. Fan Motors:
 - a. Comply with NEMA designation, temperature rating, service factor, enclosure type, and efficiency requirements specified in Division 23 Section "Common Motor Requirements for HVAC Equipment."
 - b. Multitapped, multispeed with internal thermal protection and permanent lubrication.
 - c. Wiring Terminations: Connect motor to chassis wiring with plug connection.
8. Airstream Surfaces: Surfaces in contact with the airstream shall comply with requirements in ASHRAE 62.1-2004.
9. Filters: Permanent, cleanable.
10. Condensate Drain Pans:
 - a. Fabricated with two percent slope in at least two planes to collect condensate from cooling coils (including coil piping connections, coil headers, and return bends) and humidifiers, and to direct water toward drain connection.
 - 1) Length: Extend drain pan downstream from leaving face to comply with ASHRAE 62.1-2004.
 - 2) Depth: A minimum of 2 inches deep.
 - b. Single-wall, galvanized-steel sheet, with closed foam spray coating.
 - c. Double-wall, galvanized-steel sheet with space between walls filled with foam insulation and moisture-tight seal.
 - d. Drain Connection: Located at lowest point of pan and sized to prevent overflow. Terminate with threaded nipple on one end of pan.
 - 1) Minimum Connection Size: NPS 1.
 - e. Pan-Top Surface Coating: Asphaltic waterproofing compound.
 - f. Units with stacked coils shall have an intermediate drain pan to collect condensate from top coil.

B. Floor-Mounted, Evaporator-Fan Components:

1. Cabinet: Enameled steel with removable panels on front and ends in color selected by Architect.
 - a. Discharge Grille: Steel with surface-mounted frame.
 - b. Insulation: Faced, glass-fiber duct liner.
 - c. Drain Pans: Galvanized steel, with connection for drain; insulated.
2. Refrigerant Coil: Copper tube, with mechanically bonded aluminum fins and thermal-expansion valve. Comply with ARI 210/240.
3. Water Coil: Copper tube, with mechanically bonded aluminum fins spaced no closer than 0.1 inch; leak tested to 300 psig underwater; with a two-position control valve.
4. Electric Coil: Helical, nickel-chrome, resistance-wire heating elements; with refractory ceramic support bushings, automatic-reset thermal cutout, built-in magnetic contactors, manual-reset thermal cutout, airflow proving device, and one-time fuses in terminal box for overcurrent protection.
5. Fan: Direct drive, centrifugal, with power-induced outside air.
6. Fan Motors:
 - a. Comply with NEMA designation, temperature rating, service factor, enclosure type, and efficiency requirements specified in Division 23 Section "Common Motor Requirements for HVAC Equipment."
 - b. Multitapped, multispeed with internal thermal protection and permanent lubrication.
7. Air Filtration Section:
 - a. General Requirements for Air Filtration Section:
 - 1) Comply with NFPA 90A.
 - 2) Minimum Arrestance: According to ASHRAE 52.1 and MERV according to ASHRAE 52.2.
 - 3) Filter-Holding Frames: Arranged for flat or angular orientation, with access doors on both sides of unit. Filters shall be removable from one side or lifted out from access plenum.
 - b. Disposable Panel Filters:
 - 1) Factory-fabricated, viscous-coated, flat-panel type.
 - 2) Thickness: 1 inch.
 - 3) Initial Resistance: 0.1 inches wg >.
 - 4) Recommended Final Resistance: 0.3 inches wg .
 - 5) Arrestance according to ASHRAE 52.1: 80.
 - 6) Merv according to ASHRAE 52.2: 5.
 - 7) Media: Interlaced glass fibers sprayed with nonflammable adhesive and antimicrobial agent.
 - 8) Frame: Galvanized steel, with metal grid on outlet side, steel rod grid on inlet side, and hinged; with pull and retaining handles.

- c. Extended-Surface, Disposable Panel Filters:
 - 1) Factory-fabricated, dry, extended-surface type.
 - 2) Thickness: 1 inch.
 - 3) Initial Resistance: 0.1 inches wg.
 - 4) Recommended Final Resistance: 0.4 inches wg.
 - 5) Arrestance according to ASHRAE 52.1: 90.
 - 6) Merv according to ASHRAE 52.2: 7.
 - 7) Media: Fibrous material formed into deep-V-shaped pleats with antimicrobial agent and held by self-supporting wire grid.
 - 8) Media-Grid Frame: Nonflammable cardboard.
 - 9) Mounting Frames: Welded, galvanized steel, with gaskets and fasteners; suitable for bolting together into built-up filter banks.

C. Wall-Mounted, Evaporator-Fan Components:

- 1. Cabinet: Enameled steel with removable panels on front and ends in color selected by Architect, and discharge drain pans with drain connection.
- 2. Refrigerant Coil: Copper tube, with mechanically bonded aluminum fins and thermal-expansion valve. Comply with ARI 210/240.
- 3. Electric Coil: Helical, nickel-chrome, resistance-wire heating elements; with refractory ceramic support bushings, automatic-reset thermal cutout, built-in magnetic contactors, manual-reset thermal cutout, airflow proving device, and one-time fuses in terminal box for overcurrent protection.
- 4. Fan: Direct drive, centrifugal.
- 5. Fan Motors:
 - a. Comply with NEMA designation, temperature rating, service factor, enclosure type, and efficiency requirements specified in Division 23 Section "Common Motor Requirements for HVAC Equipment."
 - b. Multitapped, multispeed with internal thermal protection and permanent lubrication.
 - c. Enclosure Type: Totally enclosed, fan cooled.
 - d. NEMA Premium (TM) efficient motors as defined in NEMA MG 1.
 - e. Controllers, Electrical Devices, and Wiring: Comply with requirements for electrical devices and connections specified in Division 26 Sections.
 - f. Mount unit-mounted disconnect switches on exterior of unit.
- 6. Airstream Surfaces: Surfaces in contact with the airstream shall comply with requirements in ASHRAE 62.1-2004.
- 7. Condensate Drain Pans:
 - a. Fabricated with two percent slope in at least two planes to collect condensate from cooling coils (including coil piping connections, coil headers, and return bends) and humidifiers, and to direct water toward drain connection.
 - 1) Length: Extend drain pan downstream from leaving face to comply with ASHRAE 62.1-2004.
 - 2) Depth: A minimum of 1 inch deep.

- b. Single-wall, galvanized-steel sheet, with closed foam spray coating.
 - c. Drain Connection: Located at lowest point of pan and sized to prevent overflow. Terminate with threaded nipple on one end of pan.
 - 1) Minimum Connection Size: NPS 1.
 - d. Pan-Top Surface Coating: Asphaltic waterproofing compound.
8. Air Filtration Section:
- a. General Requirements for Air Filtration Section:
 - 1) Comply with NFPA 90A.
 - 2) Minimum Arrestance: According to ASHRAE 52.1 and MERV according to ASHRAE 52.2.
 - 3) Filter-Holding Frames: Arranged for flat or angular orientation, with access doors on both sides of unit. Filters shall be removable from one side or lifted out from access plenum.
 - b. Disposable Panel Filters:
 - 1) Factory-fabricated, viscous-coated, flat-panel type.
 - 2) Thickness: 1 inch.
 - 3) Initial Resistance: 0.1 inches wg.
 - 4) Recommended Final Resistance: 0.3 inches wg.
 - 5) Arrestance according to ASHRAE 52.1: 80.
 - 6) Merv according to ASHRAE 52.2: 5.
 - 7) Media: Interlaced glass fibers sprayed with nonflammable adhesive and antimicrobial agent.
 - 8) Frame: Galvanized steel, with metal grid on outlet side, steel rod grid on inlet side, and hinged; with pull and retaining handles.
 - c. Extended-Surface, Disposable Panel Filters:
 - 1) Factory-fabricated, dry, extended-surface type.
 - 2) Thickness: 1 inch 2 inches 4 inches.
 - 3) Initial Resistance: 0.1 inches wg.
 - 4) Recommended Final Resistance: 0.4 inches wg.
 - 5) Arrestance according to ASHRAE 52.1: 90.
 - 6) Merv according to ASHRAE 52.2: 7.
 - 7) Media: Fibrous material formed into deep-V-shaped pleats with antimicrobial agent and held by self-supporting wire grid.
 - 8) Media-Grid Frame: Nonflammable cardboard.
 - 9) Mounting Frames: Welded, galvanized steel, with gaskets and fasteners; suitable for bolting together into built-up filter banks.

2.3 INDOOR UNITS (6 TONS OR MORE)

A. Concealed Evaporator-Fan Components:

1. Chassis: Galvanized steel with flanged edges, removable panels for servicing, and insulation on back of panel.
2. Insulation: Faced, glass-fiber duct liner.
3. Refrigerant Coil: Copper tube, with mechanically bonded aluminum fins and thermal-expansion valve. Comply with ARI 210/240.
4. Water Coil: Copper tube, with mechanically bonded aluminum fins spaced no closer than 0.1 inch; leak tested to 300 psig underwater; with a two-position control valve.
5. Electric Coil: Helical, nickel-chrome, resistance-wire heating elements; with refractory ceramic support bushings, automatic-reset thermal cutout, built-in magnetic contactors, manual-reset thermal cutout, airflow proving device, and one-time fuses in terminal box for overcurrent protection.
6. Fan: Forward-curved, double-width wheel of galvanized steel; directly connected to motor.
7. Fan Motors:
 - a. Comply with NEMA designation, temperature rating, service factor, enclosure type, and efficiency requirements specified in Division 23 Section "Common Motor Requirements for HVAC Equipment."
 - b. Multitapped, multispeed with internal thermal protection and permanent lubrication.
 - c. Three-phase, permanently lubricated, ball-bearing motors with built-in thermal-overload protection.
 - d. Wiring Terminations: Connect motor to chassis wiring with plug connection.
8. Airstream Surfaces: Surfaces in contact with the airstream shall comply with requirements in ASHRAE 62.1-2004.
9. Filters: 1 inch thick, in fiberboard frames.
10. Condensate Drain Pans:
 - a. Fabricated with two percent slope in at least two planes to collect condensate from cooling coils (including coil piping connections, coil headers, and return bends) and humidifiers, and to direct water toward drain connection.
 - 1) Length: Extend drain pan downstream from leaving face to comply with ASHRAE 62.1-2004.
 - 2) Depth: A minimum of 2 inches deep.
 - b. Single-wall, galvanized steel sheet, with closed foam spray coating.
 - c. Double-wall, galvanized steel sheet with space between walls filled with foam insulation and moisture-tight seal.
 - d. Drain Connection: Located at lowest point of pan and sized to prevent overflow. Terminate with threaded nipple on one end both ends of pan.
 - 1) Minimum Connection Size: NPS 1.
 - e. Pan-Top Surface Coating: Asphaltic waterproofing compound.
 - f. Units with stacked coils shall have an intermediate drain pan to collect condensate from top coil.

B. Floor-Mounted, Evaporator-Fan Components:

1. Cabinet: Enameled steel with removable panels on front and ends in color selected by Architect.
 - a. Discharge Grille: Steel with surface-mounted frame.
 - b. Insulation: Faced, glass-fiber duct liner.
2. Condensate Drain Pans:
 - a. Fabricated with two percent slope in at least two planes to collect condensate from cooling coils (including coil piping connections, coil headers, and return bends) and humidifiers, and to direct water toward drain connection.
 - 1) Length: Extend drain pan downstream from leaving face to comply with ASHRAE 62.1-2004.
 - 2) Depth: A minimum of 2 inches deep.
 - b. Single-wall, galvanized steel sheet, with closed foam spray coating.
 - c. Double-wall, galvanized-steel sheet with space between walls filled with foam insulation and moisture-tight seal.
 - d. Drain Connection: Located at lowest point of pan and sized to prevent overflow. Terminate with threaded nipple on one end of pan.
 - 1) Minimum Connection Size: NPS 1 NPS 2.
 - e. Pan-Top Surface Coating: Asphaltic waterproofing compound.
 - f. Units with stacked coils shall have an intermediate drain pan to collect condensate from top coil.
3. Refrigerant Coil: Copper tube, with mechanically bonded aluminum fins and thermal-expansion valve. Comply with ARI 210/240.
4. Water Coil: Copper tube, with mechanically bonded aluminum fins spaced no closer than 0.1 inch; leak tested to 300 psig underwater; with a two-position control valve.
5. Electric Coil: Helical, nickel-chrome, resistance-wire heating elements; with refractory ceramic support bushings, automatic-reset thermal cutout, built-in magnetic contactors, manual-reset thermal cutout, airflow proving device, and one-time fuses in terminal box for overcurrent protection.
6. Fan: Direct drive, centrifugal, with power-induced outside air.
7. Fan Motors:
 - a. Comply with NEMA designation, temperature rating, service factor, enclosure type, and efficiency requirements specified in Division 23 Section "Common Motor Requirements for HVAC Equipment."
 - b. Multitapped, multispeed with internal thermal protection and permanent lubrication.
 - c. Enclosure Type: Totally enclosed, fan cooled.
 - d. NEMA Premium (TM) efficient motors as defined in NEMA MG 1.
 - e. Controllers, Electrical Devices, and Wiring: Comply with requirements for electrical devices and connections specified in Division 26 Sections.
 - f. Mount unit-mounted disconnect switches on exterior of unit.

8. Air Filtration Section:

a. General Requirements for Air Filtration Section:

- 1) Comply with NFPA 90A.
- 2) Minimum Arrestance: According to ASHRAE 52.1 and a MERV according to ASHRAE 52.2.
- 3) Filter-Holding Frames: Arranged for flat or angular orientation, with access doors on both sides of unit. Filters shall be removable from one side or lifted out from access plenum.

b. Disposable Panel Filters:

- 1) Factory-fabricated, viscous-coated, flat-panel type.
- 2) Thickness: 2 inches.
- 3) Initial Resistance: 0.1 inches wg.
- 4) Recommended Final Resistance: 0.3 inches wg .
- 5) Arrestance according to ASHRAE 52.1: 80.
- 6) Merv according to ASHRAE 52.2: 5.
- 7) Media: Interlaced glass fibers sprayed with nonflammable adhesive and antimicrobial agent.
- 8) Frame: Galvanized steel, with metal grid on outlet side, steel rod grid on inlet side, and hinged; with pull and retaining handles.

c. Extended-Surface, Disposable Panel Filters:

- 1) Factory-fabricated, dry, extended-surface type.
- 2) Thickness: 1 inch.
- 3) Initial Resistance: 0.1 inches wg.
- 4) Recommended Final Resistance: 0.4 inches wg.
- 5) Arrestance according to ASHRAE 52.1: 90 >.
- 6) Merv according to ASHRAE 52.2: 7.
- 7) Media: Fibrous material formed into deep-V-shaped pleats with antimicrobial agent and held by self-supporting wire grid.
- 8) Media-Grid Frame: Nonflammable cardboard.
- 9) Mounting Frames: Welded, galvanized steel, with gaskets and fasteners; suitable for bolting together into built-up filter banks.

C. Variable-Frequency Controllers:

1. Description: NEMA ICS 2, IGBT, PWM, VFC; listed and labeled as a complete unit and arranged to provide variable speed of an NEMA MG 1, Design B, three-phase induction motor by adjusting output voltage and frequency.
2. Output Rating: Three-phase; 6 to 60 Hz, with voltage proportional to frequency throughout voltage range.
3. Unit Operating Requirements:
 - a. Input ac voltage tolerance of 208 V, plus or minus 5percent.
 - b. Input-frequency tolerance of 50/60 Hz, plus or minus 6 percent.
 - c. Minimum Efficiency: 96 percent at 60 Hz, full load.

- d. Minimum Displacement Primary-Side Power Factor: 96 percent.
 - e. Overload Capability: 1.1 times the base load current for 60 seconds; 2.0 times the base load current for 3 seconds.
 - f. Starting Torque: 100 percent of rated torque or as indicated.
 - g. Speed Regulation: Plus or minus 1 percent.
4. Isolated control interface to allow controller to follow control signal over an 11:1 speed range.
 5. Internal Adjustability Capabilities:
 - a. Minimum Speed: 5 to 25 percent of maximum rpm.
 - b. Maximum Speed: 80 to 100 percent of maximum rpm.
 - c. Acceleration: 2 seconds to a minimum of 22 seconds.
 - d. Deceleration: 2 seconds to a minimum of 22 seconds.
 - e. Current Limit: 50 percent to a minimum of 110 percent of maximum rating.
 6. Self-Protection and Reliability Features:
 - a. Input transient protection by means of surge suppressors.
 - b. Undervoltage and overvoltage trips; inverter overtemperature, overload, and overcurrent trips.
 - c. Adjustable motor overload relays capable of NEMA ICS 2, Class 10 performance.
 - d. Notch filter to prevent operation of the controller-motor-load combination at a natural frequency of the combination.
 - e. Instantaneous line-to-line and line-to-ground overcurrent trips.
 - f. Loss-of-phase protection.
 - g. Reverse-phase protection.
 - h. Short-circuit protection.
 - i. Motor overtemperature fault.
 7. Automatic Reset/Restart: Attempts three restarts after controller fault or on return of power after an interruption and before shutting down for manual reset or fault correction. Bidirectional autospeed search shall be capable of starting into rotating loads, spinning in either direction and returning motor to set speed in proper direction, without damage to controller, motor, or load.
 8. Power-Interruption Protection: Prevents motor from re-energizing after a power interruption until motor has stopped.
 9. Torque Boost: Automatically varies starting and continuous torque to at least 1.5 times the minimum torque to ensure high-starting torque and increased torque at slow speeds.
 10. Motor Temperature Compensation at Slow Speeds: Adjustable current fall-back, based on output frequency for temperature protection of self-cooled, fan-ventilated motors at slow speeds.
 11. Door-mounted, digital status lights shall indicate the following conditions:
 - a. Power on.
 - b. Run.
 - c. Overvoltage.
 - d. Line fault.
 - e. Overcurrent.
 - f. External fault.

12. Panel-Mounted Operator Station: Start-stop and auto-manual selector switches with manual-speed-control potentiometer and elapsed-time meter.
13. Meters or digital readout devices and selector switch, mounted flush in controller door and connected, to indicate the following controller parameters:
 - a. Output frequency (Hertz).
 - b. Motor speed (rpm).
 - c. Motor status (running, stop, fault).
 - d. Motor current (amperes).
 - e. Motor torque (percent).
 - f. Fault or alarming status (code).
 - g. Proportional-integral-derivative feedback signal (percent).
 - h. DC-link voltage (volts dc).
 - i. Set-point frequency (Hertz).
 - j. Motor output voltage (volts).
14. Control Signal Interface:
 - a. Electric Input Signal Interface: A minimum of two analog inputs (0 to 10 V or 0/4-20 mA) and six programmable digital inputs.
 - b. Remote signal inputs capable of accepting any of the following speed-setting input signals from the control system:
 - 1) 0 to 10-V dc.
 - 2) 0-20 or 4-20 mA.
 - 3) Potentiometer using up/down digital inputs.
 - 4) Fixed frequencies using digital inputs.
 - 5) RS485.
 - 6) Keypad display for local hand operation.
 - c. Output signal interface with a minimum of one analog output signal (0/4-20 mA), which can be programmed to any of the following:
 - 1) Output frequency (Hertz).
 - 2) Output current (load).
 - 3) DC-link voltage (volts dc).
 - 4) Motor torque (percent).
 - 5) Motor speed (rpm).
 - 6) Set-point frequency (Hertz).
 - d. Remote indication interface with a minimum of two dry circuit relay outputs (120-V ac, 1 A) for remote indication of the following:
 - 1) Motor running.
 - 2) Set-point speed reached.
 - 3) Fault and warning indication (overtemperature or overcurrent).
 - 4) High- or low-speed limits reached.
15. Communications: RS485 interface allows VFC to be used with an external system within a multidrop LAN configuration. Interface shall allow all parameter settings of VFC to be

- programmed via BMS control. Provide capability for VFC to retain these settings within the nonvolatile memory.
16. Integral Disconnecting Means: NEMA AB 1, instantaneous-trip circuit breaker with lockable handle.
 17. Accessories:
 - a. Devices shall be factory installed in controller enclosure unless otherwise indicated.
 - b. Push-Button Stations, Pilot Lights, and Selector Switches: NEMA ICS 2, heavy-duty type.
 - c. Standard Displays:
 - 1) Output frequency (Hertz).
 - 2) Set-point frequency (Hertz).
 - 3) Motor current (amperes).
 - 4) DC-link voltage (volts dc).
 - 5) Motor torque (percent).
 - 6) Motor speed (rpm).
 - 7) Motor output voltage (volts).

2.4 OUTDOOR UNITS (5 TONS OR LESS)

A. Air-Cooled, Compressor-Condenser Components:

1. Casing: Steel, finished with baked enamel in color selected by Architect, with removable panels for access to controls, weep holes for water drainage, and mounting holes in base. Provide brass service valves, fittings, and gage ports on exterior of casing.
2. Compressor: Hermetically sealed with crankcase heater and mounted on vibration isolation device. Compressor motor shall have thermal- and current-sensitive overload devices, start capacitor, relay, and contactor.
 - a. Compressor Type: Scroll.
 - b. Two-speed compressor motor with manual-reset high-pressure switch and automatic-reset low-pressure switch.
 - c. Refrigerant Charge: R-410A.
 - d. Refrigerant Coil: Copper tube, with mechanically bonded aluminum fins and liquid subcooler. Comply with ARI 210/240.
3. Heat-Pump Components: Reversing valve and low-temperature-air cutoff thermostat.
4. Fan: Aluminum-propeller type, directly connected to motor.
5. Motor: Permanently lubricated, with integral thermal-overload protection.
6. Low Ambient Kit: Permits operation down to 45 deg F.
7. Mounting Base: Polyethylene.

2.5 OUTDOOR UNITS (6 TONS OR MORE)

A. Air-Cooled, Compressor-Condenser Components:

1. Casing: Steel, finished with baked enamel in color selected by Architect, with removable panels for access to controls, weep holes for water drainage, and mounting holes in base. Provide brass service valves, fittings, and gage ports on exterior of casing.
2. Compressor: Hermetically sealed with crankcase heater and mounted on vibration isolation device. Compressor motor shall have thermal- and current-sensitive overload devices, start capacitor, relay, and contactor.
 - a. Compressor Type: Scroll.
 - b. Two-speed compressor motor with manual-reset high-pressure switch and automatic-reset low-pressure switch.
 - c. Refrigerant Charge: R-410A.
 - d. Refrigerant Coil: Copper tube, with mechanically bonded aluminum fins and liquid subcooler. Comply with ARI 210/240.
3. Heat-Pump Components: Reversing valve and low-temperature-air cutoff thermostat.
4. Fan: Aluminum-propeller type, directly connected to motor.
5. Motor: Permanently lubricated, with integral thermal-overload protection.
6. Low Ambient Kit: Permits operation down to 45 deg F.
7. Mounting Base: Polyethylene.

B. Water-Cooled, Compressor-Condenser Components:

1. Casing: Steel, finished with baked enamel in color selected by Architect, with removable panels for access to controls and mounting holes in base. Provide brass service valves, fittings, and gage ports on exterior of casing.
2. Compressor: Hermetically sealed with crankcase heater and mounted on vibration isolation device. Compressor motor shall have thermal- and current-sensitive overload devices, start capacitor, relay, and contactor.
 - a. Compressor Type: Scroll.
 - b. Two-speed compressor motor with manual-reset high-pressure switch and automatic-reset low-pressure switch.
 - c. Refrigerant Charge R-410A.
3. Heat-Pump Components: Reversing valve.
4. Heat Exchanger: Copper tubes in copper tube or in steel shell, with water-temperature-actuated, water-regulating valve.

2.6 ACCESSORIES

- A. Control equipment and sequence of operation are specified in Division 23 Sections "Direct Digital Control (DDC) for HVAC."
- B. Thermostat: Low voltage with subbase to control compressor and evaporator fan.
- C. Thermostat: Wireless infrared functioning to remotely control compressor and evaporator fan, with the following features:
 1. Compressor time delay.

2. 24-hour time control of system stop and start.
 3. Liquid-crystal display indicating temperature, set-point temperature, time setting, operating mode, and fan speed.
 4. Fan-speed selection including auto setting.
- D. Automatic-reset timer to prevent rapid cycling of compressor.
- E. Refrigerant Line Kits: Soft-annealed copper suction and liquid lines factory cleaned, dried, pressurized, and sealed; factory-insulated suction line with flared fittings at both ends.
- F. Drain Hose: For condensate.
- G. Additional Monitoring:
1. Monitor constant and variable motor loads.
 2. Monitor variable-frequency-drive operation.
 3. Monitor economizer cycle.
 4. Monitor cooling load.
 5. Monitor air distribution static pressure and ventilation air volumes.

2.7 CAPACITIES AND CHARACTERISTICS

- A. Cooling Capacity: As indicated on drawings.
- B. Heating Capacity: As indicated on drawings.
- C. Auxiliary Heating Capacity: As indicated on drawings.
- D. Indoor Unit:
1. Fan Motor Electrical Characteristics: As indicated on drawings.
- E. Outdoor Unit:
1. Type: Air cooled.
 2. Electrical Characteristics: As indicated on drawings.

PART 3 - EXECUTION

3.1 INSTALLATION

- A. Install units level and plumb.
- B. Install evaporator-fan components using manufacturer's standard mounting devices securely fastened to building structure.
- C. Install ground-mounted, compressor-condenser components on 4-inch- thick, reinforced concrete base that is 4 inches larger, on each side, than unit. Concrete, reinforcement, and

formwork are specified in Division 03 Section "Cast-in-Place Concrete." Coordinate anchor installation with concrete base.

- D. Install ground-mounted, compressor-condenser components on polyethylene mounting base.
- E. Install roof-mounted, compressor-condenser components on equipment supports specified in Division 07 Section "Roof Accessories." Anchor units to supports with removable, cadmium-plated fasteners.
- F. Install seismic restraints.
- G. Install compressor-condenser components on restrained, spring isolators with a minimum static deflection of 1 inch. See Division 23 Section "Vibration Controls for HVAC."
- H. Install and connect precharged refrigerant tubing to component's quick-connect fittings. Install tubing to allow access to unit.

3.2 CONNECTIONS

- A. Piping installation requirements are specified in other Division 23 Sections. Drawings indicate general arrangement of piping, fittings, and specialties.
 - 1. Water Coil Connections: Comply with requirements specified in Division 23 Section "Hydronic Piping." Connect hydronic piping to supply and return coil connections with shutoff-duty valve and union or flange on the supply connection and with throttling-duty valve and union or flange on the return connection.
 - 2. Remote, Water-Cooled Condenser Connections: Comply with requirements specified in Division 23 Section "Hydronic Piping." Connect hydronic piping to supply and return connections with shutoff-duty valve and union or flange on the supply connection and with throttling-duty valve and union or flange on the return connection.
- B. Where piping is installed adjacent to unit, allow space for service and maintenance of unit.
- C. Duct Connections: Duct installation requirements are specified in Division 23 Section "Metal Ducts" Drawings indicate the general arrangement of ducts. Connect supply and return ducts to split-system air-conditioning units with flexible duct connectors. Flexible duct connectors are specified in Division 23 Section "Air Duct Accessories."

3.3 FIELD QUALITY CONTROL

- A. Manufacturer's Field Service: Engage a factory-authorized service representative to inspect, test, and adjust components, assemblies, and equipment installations, including connections.
- B. Perform tests and inspections.
 - 1. Manufacturer's Field Service: Engage a factory-authorized service representative to inspect components, assemblies, and equipment installations, including connections, and to assist in testing.

C. Tests and Inspections:

1. Leak Test: After installation, charge system and test for leaks. Repair leaks and retest until no leaks exist.
2. Operational Test: After electrical circuitry has been energized, start units to confirm proper motor rotation and unit operation.
3. Test and adjust controls and safeties. Replace damaged and malfunctioning controls and equipment.

D. Remove and replace malfunctioning units and retest as specified above.

E. Prepare test and inspection reports.

3.4 STARTUP SERVICE

A. Engage a factory-authorized service representative to perform startup service.

1. Complete installation and startup checks according to manufacturer's written instructions.

3.5 DEMONSTRATION

A. Owner's maintenance personnel to adjust, operate, and maintain units.

END OF SECTION 238126

SECTION 238219 - FAN COIL UNITS

PART 1 - GENERAL

1.1 RELATED DOCUMENTS

- A. Drawings and general provisions of the Contract, including General and Supplementary Conditions and Division 01 Specification Sections, apply to this Section.

1.2 SUMMARY

- A. This Section includes fan-coil units and accessories.

1.3 DEFINITIONS

- A. BAS: Building automation system.

1.4 SUBMITTALS

- A. Product Data: Include rated capacities, operating characteristics, furnished specialties, and accessories.
- B. Shop Drawings: Detail equipment assemblies and indicate dimensions, weights, loads, required clearances, method of field assembly, components, and location and size of each field connection.
 - 1. Wiring Diagrams: Power, signal, and control wiring.
- C. Coordination Drawings: Floor plans, reflected ceiling plans, and other details, drawn to scale, on which the following items are shown and coordinated with each other, based on input from installers of the items involved:
 - 1. Ceiling suspension components.
 - 2. Structural members to which fan-coil units will be attached.
 - 3. Method of attaching hangers to building structure.
 - 4. Size and location of initial access modules for acoustical tile.
 - 5. Items penetrating finished ceiling, including the following:
 - a. Lighting fixtures.
 - b. Air outlets and inlets.
 - c. Speakers.
 - d. Sprinklers.
 - e. Access panels.
 - f. Ceiling mounted projectors and projection screens.

6. Perimeter moldings for exposed or partially exposed cabinets.
 - D. Samples for Initial Selection: For units with factory-applied color finishes.
 - E. Samples for Verification: For each type of fan-coil unit indicated.
 - F. Manufacturer Seismic Qualification Certification: Submit certification that fan-coil units, accessories, and components will withstand seismic forces defined in Division 23 Section "Vibration Controls for HVAC." Include the following:
 1. Basis for Certification: Indicate whether withstand certification is based on actual test of assembled components or on calculation.
 - a. The term "withstand" means "the unit will remain in place without separation of any parts from the device when subjected to the seismic forces specified."
 - b. The term "withstand" means "the unit will remain in place without separation of any parts from the device when subjected to the seismic forces specified and the unit will be fully operational after the seismic event."
 2. Dimensioned Outline Drawings of Equipment Unit: Identify center of gravity and locate and describe mounting and anchorage provisions.
 3. Detailed description of equipment anchorage devices on which the certification is based and their installation requirements.
 - G. Field quality-control test reports.
 - H. Operation and Maintenance Data: For fan-coil units to include in emergency, operation, and maintenance manuals. In addition to items specified in Division 01 Section "Operation and Maintenance Data," include the following:
 1. Maintenance schedules and repair part lists for motors, coils, integral controls, and filters.
 - I. Warranty: Special warranty specified in this Section.
- 1.5 QUALITY ASSURANCE
- A. Electrical Components, Devices, and Accessories: Listed and labeled as defined in NFPA 70, Article 100, by a testing agency acceptable to authorities having jurisdiction, and marked for intended use.
 - B. ASHRAE Compliance: Applicable requirements in ASHRAE 62.1-2004, Section 5 - "Systems and Equipment" and Section 7 - "Construction and Startup."
 - C. ASHRAE/IESNA 90.1-2004 Compliance: Applicable requirements in ASHRAE/IESNA 90.1-2004, Section 6 - "Heating, Ventilating, and Air-Conditioning."

1.6 COORDINATION

- A. Coordinate layout and installation of fan-coil units and suspension system components with other construction that penetrates or is supported by ceilings, including light fixtures, HVAC equipment, fire-suppression-system components, partition assemblies, and AV equipment.
- B. Coordinate size and location of wall sleeves for outdoor-air intake.

PART 2 - PRODUCTS

2.1 MANUFACTURERS

- A. In other Part 2 articles where titles below introduce lists, the following requirements apply to product selection:
- B. In the Fan-Coil-Unit Schedule where titles below are column or row headings that introduce lists, the following requirements apply to product selection:
 - 1. Available Manufacturers: Subject to compliance with requirements, manufacturers offering products that may be incorporated into the Work include, but are not limited to, manufacturers specified.
 - 2. Manufacturers: Subject to compliance with requirements, provide products by one of the manufacturers specified.
 - 3. Basis-of-Design Product: The design for each fan-coil unit is based on the product named. Subject to compliance with requirements, provide either the named product or a comparable product by one of the other manufacturers specified.

2.2 FAN-COIL UNITS

- A. Basis-of-Design Product: Select a comparable product by one of the following or approved equal:
- B. Manufacturers:
 - 1. Airtherm; a Mestek Company.
 - 2. Carrier Corporation.
 - 3. Engineered Air Ltd.
 - 4. Environmental Technologies, Inc.
 - 5. International Environmental Corporation.
 - 6. Daikin.
 - 7. Trane.
 - 8. USA Coil & Air.
 - 9. YORK International Corporation.
- C. Description: Factory-packaged and -tested units rated according to ARI 440, ASHRAE 33, and UL 1995.

- D. Coil Section Insulation: 1-inch thick, matte-finish, closed-cell foam complying with ASTM C 1071 and attached with adhesive complying with ASTM C 916.
 - 1. Fire-Hazard Classification: Insulation and adhesive shall have a combined maximum flame-spread index of 25 and smoke-developed index of 50 when tested according to ASTM E 84.
 - 2. Airstream Surfaces: Surfaces in contact with the airstream shall comply with requirements in ASHRAE 62.1-2004.
- E. Main and Auxiliary Drain Pans: Insulated galvanized steel with plastic liner. Fabricate pans and drain connections to comply with ASHRAE 62.1-2004.
- F. Chassis: Galvanized steel where exposed to moisture. Floor-mounting units shall have leveling screws.
- G. Cabinet: Steel with baked-enamel finish in manufacturer's standard paint color as selected by Architect.
 - 1. Vertical Unit Front Panels: Removable, steel, with integral stamped steel discharge grille and channel-formed edges, cam fasteners, and insulation on back of panel.
 - 2. Horizontal Unit Bottom Panels: Fastened to unit with cam fasteners and hinge and attached with safety chain; with integral stamped cast-aluminum discharge grilles.
 - 3. Stack Unit Discharge and Return Grille: Aluminum double-deflection discharge grille, and louvered- or panel-type return grille; color as selected by Architect from manufacturer's standard colors. Return grille shall provide maintenance access to fan-coil unit.
 - 4. Steel recessing flanges for recessing fan-coil units into ceiling or wall.
- H. Outdoor-Air Wall Box: Minimum 0.1265-inch- thick, aluminum, rain-resistant louver and box with integral eliminators and bird screen.
 - 1. Louver Configuration: Horizontal, rain-resistant louver.
 - 2. Louver Material: Aluminum.
 - 3. Bird Screen: 1/2-inch mesh screen on interior side of louver.
 - 4. Decorative Grille: On outside of intake.
 - 5. Finish: Baked enamel, color as selected by Architect from manufacturer's standard, custom colors.
- I. Outdoor-Air Damper: Galvanized-steel blades with edge and end seals and nylon bearings; modulating actuators.
- J. Filters: Minimum arrestance according to ASHRAE 52.1, and a minimum efficiency reporting value (MERV) according to ASHRAE 52.2.
 - 1. Glass Fiber Treated with Adhesive: 80 percent arrestance and 5 MERV.
- K. Hydronic Coils: Copper tube, with mechanically bonded aluminum fins spaced no closer than 0.1 inch, rated for a minimum working pressure of 200 psig and a maximum entering-water temperature of 220 deg F. Include manual air vent and drain valve.
- L. Steam Coils: Copper distributing tube, with mechanically bonded aluminum fins spaced no closer than 0.1 inch, rated for a minimum working pressure of 75 psig.

- M. Electric-Resistance Heating Coils: Nickel-chromium heating wire, free of expansion noise and hum, mounted in ceramic inserts in a galvanized-steel housing; with fuses in terminal box for overcurrent protection and limit controls for high-temperature protection. Terminate elements in stainless-steel machine-staked terminals secured with stainless-steel hardware.
- N. Fan and Motor Board: Removable.
1. Fan: Forward curved, double width, centrifugal; directly connected to motor. Thermoplastic or painted-steel wheels, and aluminum, painted-steel, or galvanized-steel fan scrolls.
 2. Motor: Permanently lubricated, multispeed; resiliently mounted on motor board. Comply with requirements in Division 23 Section "Common Motor Requirements for HVAC Equipment."
 3. Motor: High efficiency electronically commutated (EC) motors shall be included. Motor voltage shall match single point connection capacity at 60Hz. Motor can be regulated by 0-10V dc signal supplied by a BMS, thermostat or DDC controller. The motor is resiliently mounted, self aligning and oiled for life.
 4. Wiring Termination: Connect motor to chassis wiring with plug connection.
- O. Factory, Hydronic Piping Package: ASTM B 88, copper tube with wrought-copper fittings and brazed joints. Label piping to indicate service, inlet, and outlet.
1. Modulating Control valves shall be Pressure Independent Type (See requirements in section 230923). Valve packs with half unions are not acceptable – connections at control valves must be full union.
 - a. Modulating control valve for dual-temperature coil.
 - b. Modulating control valve for chilled-water coil.
 - c. Modulating control valve for heating coil.
 - d. Modulating control valve for hot-water reheat coil.
 2. Two-Piece Ball Valves: Bronze body with full-port, chrome-plated bronze ball; PTFE or TFE seats; and 600-psig minimum CWP rating and blowout-proof stem.
 3. Automatic Flow-Control Valve: Brass or ferrous-metal body; 300-psig working pressure at 250 deg F, with removable, corrosion-resistant, tamperproof, self-cleaning piston spring; factory set to maintain constant indicated flow with plus or minus 10 percent over differential pressure range of 2 to 80 psig.
 - a. Bell & Gossett
 - b. Belimo
 - c. Griswold
 - d. Delta P
 4. Y-Pattern Hydronic Strainers: Cast-iron body ASTM A 126, Class B; 125-psig working pressure; with threaded connections, bolted cover, perforated stainless-steel basket, and bottom drain connection. Include minimum NPS 1/2 hose-end, full-port, ball-type blowdown valve in drain connection.
 5. Wrought-Copper Unions: ASME B16.22.
 6. Risers: ASTM B 88, Type L copper pipe with hose and ball valve for system flushing.
- P. Control devices and operational sequences are specified in Division 23 Sections "Direct Digital Control (DDC) for HVAC." Refer to drawings for project specific sequence of operation. Unit shall contain native BACNET protocol. Controllers shall be provided by the BAS contractor.

General contractor to coordinate if they will be field installed (for project with minimal number of units) or factory installed (for a project with a large number of units). FCU Controller to be fully integrated into UMD CCMS.

- a. Drain Pan overflow float switch (upon initiation of float switch chilled water coil shall close and fan shall continue to operate).

Q. Basic Unit Controls:

1. Provide Control voltage transformer.
2. Wall-mounting thermostat with the following features:
 - a. Heat-cool-off switch.
 - b. Fan-speed switch.
 - c. Manual changeover.
 - d. Adjustable deadband.
 - e. Exposed set point.
 - f. Exposed indication.
 - g. Adjustable slide for local temperature adjustment
 - h. Degree F indication.
3. Wall-mounting humidistat (as indicated on drawings).
4. Wall-mounting temperature sensor.
5. Unoccupied-period-override push button.
6. Where integral DDC controller is utilized the points for integral FCU controller shall be directly integrated utilizing BacNet protocol to the UMD CCMS system (do not provide a micro-gateway).

R. Electrical Connection: Factory wire motors and controls for a single electrical connection.

S. Capacities and Characteristics:

1. Fan: As indicated
2. Cooling Capacity: As indicated
3. Heating Capacity: As indicated
4. Electrical Characteristics for Single-Point Connection: As indicated

2.3 DUCTED FAN-COIL UNITS

A. Basis-of-Design Product: product by one of the following or approved equal.

B. Available Manufacturers:

1. Carrier Corporation.
2. Engineered Air Ltd.
3. Environmental Technologies, Inc.
4. International Environmental Corporation.

5. McQuay International.
 6. Trane.
 7. USA Coil & Air.
 8. YORK International Corporation.
- C. Description: Factory-packaged and -tested units rated according to ARI 440, ASHRAE 33, and UL 1995.
- D. Coil Section Insulation: 1-inch thick coated glass fiber complying with ASTM C 1071 and attached with adhesive complying with ASTM C 916.
1. Fire-Hazard Classification: Insulation and adhesive shall have a combined maximum flame-spread index of 25 and smoke-developed index of 50 when tested according to ASTM E 84.
 2. Airstream Surfaces: Surfaces in contact with the airstream shall comply with requirements in ASHRAE 62.1-2004.
- E. Drain Pans: Insulated galvanized steel with plastic liner. Fabricate pans and drain connections to comply with ASHRAE 62.1-2004.
- F. Chassis: Galvanized steel where exposed to moisture, with baked-enamel finish and removable access panels.
- G. Cabinets: Steel with baked-enamel finish in manufacturer's standard paint color.
1. Supply-Air Plenum: Sheet metal plenum finished and insulated to match the chassis with mill-finish, aluminum, double-deflection grille.
 2. Return-Air Plenum: Sheet metal plenum finished to match the chassis.
 3. Mixing Plenum: Sheet metal plenum finished and insulated to match the chassis with outdoor- and return-air, formed-steel dampers.
 4. Dampers: Galvanized steel with extruded-vinyl blade seals, flexible-metal jamb seals, and interlocking linkage.
- H. Filters: Minimum arrestance according to ASHRAE 52.1, and a minimum efficiency reporting value (MERV) according to ASHRAE 52.2.
1. Glass Fiber Treated with Adhesive: 80 percent arrestance and 5 MERV.
- I. Hydronic Coils: Copper tube, with mechanically bonded aluminum fins spaced no closer than 0.1 inch, rated for a minimum working pressure of 200 psig and a maximum entering-water temperature of 220 deg F. Include manual air vent and drain.
- J. Steam Coils: Copper tube, with mechanically bonded aluminum fins spaced no closer than 0.1 inch, rated for a minimum working pressure of 75 psig.
- K. Electric-Resistance Heating Coils: Nickel-chromium heating wire, free of expansion noise and hum, mounted in ceramic inserts in a galvanized-steel housing; with fuses in terminal box for overcurrent protection and limit controls for high-temperature protection of heaters. Terminate elements in stainless-steel machine-staked terminals secured with stainless-steel hardware.

- L. Direct-Driven Fans: Double width, forward curved, centrifugal; with permanently lubricated, multispeed motor resiliently mounted in the fan inlet. Aluminum or painted-steel wheels, and painted-steel or galvanized-steel fan scrolls.
- M. Belt-Driven Fans: Double width, forward curved, centrifugal; with permanently lubricated, single-speed motor installed on an adjustable fan base resiliently mounted in the cabinet. Aluminum or painted-steel wheels, and painted-steel or galvanized-steel fan scrolls.
 - 1. Motors: Comply with requirements in Division 23 Section "Common Motor Requirements for HVAC Equipment."
 - 2. Motors for Direct Drive Fans: High efficiency electronically commutated (EC) motors shall be included. Motor voltage shall match single point connection capacity at 60Hz. Motor can be regulated by 0-10V dc signal supplied by a BMS, thermostat or DDC controller. The motor is resiliently mounted, self aligning and oiled for life.
- N. Factory, Hydronic Piping Package: ASTM B 88, Type L (ASTM B 88M, Type B) ASTM B 88, Type M (ASTM B 88M Type C) copper tube with wrought-copper fittings and brazed joints. Label piping to indicate service, inlet, and outlet.
 - 1. Modulating Control valves shall be Pressure Independent Type (See requirements in section 230923). Valve packs with half unions are not acceptable – connections at control valves must be full union.
 - a. Modulating control valve for dual-temperature coil.
 - b. Modulating control valve for chilled-water coil.
 - c. Modulating control valve for heating coil.
 - d. Modulating control valve for hot-water reheat coil.
 - 2. Two-Piece Ball Valves: Bronze body with full-port, chrome-plated bronze ball; PTFE or TFE seats; and 600-psig minimum CWP rating and blowout-proof stem.
 - 3. Automatic Flow-Control Valve: Brass or ferrous-metal body; 300-psig working pressure at 250 deg F; with removable, corrosion-resistant, tamperproof, self-cleaning piston spring; factory set to maintain constant indicated flow with plus or minus 10 percent over differential pressure range of 2 to 80 psig.
 - a. Bell & Gossett
 - b. Belimo
 - c. Griswold
 - d. Delta P
 - 4. Y-Pattern Hydronic Strainers: Cast-iron body (ASTM A 126, Class B); 125-psig working pressure, with threaded connections, bolted cover, perforated stainless-steel basket, and bottom drain connection. Include minimum NPS ½ hose-end, full-port, ball-type blowdown valve in drain connection.
 - 5. Wrought-Copper Unions: ASME B16.22.
 - 6. Accessories: Polyethylene mounting base to provide a permanent foundation.
- O. Control devices and operational sequences are specified in Division 23 Sections "Direct Digital Control (DDC) for HVAC." Refer to drawings for project specific sequence of operation. Unit shall contain native BACNET protocol. Controllers shall be provided by the BAS contractor. General contractor to coordinate if they will be field installed (for project with minimal number

of units) or factory installed (for a project with a large number of units). FCU Controller to be fully integrated into UMD CCMS.

- a. Drain Pan overflow float switch (upon initiation of float switch chilled water coil shall close and fan shall continue to operate).

P. Basic Unit Controls:

1. Provide Control voltage transformer.
2. Wall-mounting thermostat with the following features:
 - a. Heat-cool-off switch.
 - b. Fan-speed switch.
 - c. Manual changeover.
 - d. Adjustable deadband.
 - e. Exposed set point.
 - f. Exposed indication.
 - g. Adjustable slide for local temperature adjustment
 - h. Degree F indication.
3. Wall-mounting humidistat (as indicated on drawings).
4. Wall-mounting temperature sensor.
5. Unoccupied-period-override push button.
6. Where integral DDC controller is utilized the points for integral FCU controller shall be directly integrated utilizing BacNet protocol to the UMD CCMS system (do not provide a micro-gateway).

Q. Electrical Connection: Factory wire motors and controls for a single electrical connection.

R. Capacities and Characteristics:

1. As indicated in Mechanical Schedules

PART 3 - EXECUTION

3.1 EXAMINATION

- A. Examine areas to receive fan-coil units for compliance with requirements for installation tolerances and other conditions affecting performance.
- B. Examine roughing-in for piping and electrical connections to verify actual locations before fan-coil-unit installation.
- C. Proceed with installation only after unsatisfactory conditions have been corrected.

3.2 INSTALLATION

- A. Install fan-coil units level and plumb.

- B. Install fan-coil units to comply with NFPA 90A.
- C. Suspend fan-coil units from structure with elastomeric hangers. Vibration isolators are specified in Division 23 Section "Vibration Controls for HVAC."
- D. Verify locations of thermostats, Drawings and room details before installation. Install devices 48 inches, above finished floor.
- E. Install new filters in each fan-coil unit within two weeks after Substantial Completion.

3.3 CONNECTIONS

- A. Piping installation requirements are specified in other Division 23 Sections. Drawings indicate general arrangement of piping, fittings, and specialties. Specific connection requirements are as follows:
 - 1. Install piping adjacent to machine to allow service and maintenance.
 - 2. Connect piping to fan-coil-unit factory hydronic piping package. Install piping package if shipped loose.
 - 3. Connect condensate drain to indirect waste.
 - a. Install condensate trap of adequate depth to seal against the pressure of fan. Install cleanouts in piping at changes of direction.
- B. Connect supply and return ducts to fan-coil units with flexible duct connectors specified in Division 23 Section "Air Duct Accessories." Comply with safety requirements in UL 1995 for duct connections.
- C. Ground equipment according to Division 26 Section "Grounding and Bonding for Electrical Systems."
- D. Connect wiring according to Division 26 Section "Low-Voltage Electrical Power Conductors and Cables." Control panels shall not have wiring exceeding 120 volts inside the panel.
- E. Building Automation System according to Division 23 Section "Direct Digital Control (DDC) for HVAC."

3.4 FIELD QUALITY CONTROL

- A. Manufacturer's Field Service: Engage a factory-authorized service representative to inspect, test, and adjust field-assembled components and equipment installation, including connections, and to assist in field testing. Report results in writing.
- B. Perform the following field tests and inspections and prepare test reports:
 - 1. Operational Test: After electrical circuitry has been energized, start units to confirm proper motor rotation and unit operation.

2. Operate electric heating elements through each stage to verify proper operation and electrical connections.
3. Test and adjust controls and safety devices. Replace damaged and malfunctioning controls and equipment.

C. Remove and replace malfunctioning units and retest as specified above.

3.5 ADJUSTING

- A. Adjust initial temperature set points.

3.6 DEMONSTRATION

- A. Engage a factory-authorized service representative to train Owner's maintenance personnel to adjust, operate, and maintain fan-coil units. Refer to Division 01 Section "Contract Close Out."

END OF SECTION 238219

SECTION 238223 - UNIT VENTILATORS

PART 1 - GENERAL

1.1 RELATED DOCUMENTS

- A. Drawings and general provisions of the Contract, including General and Supplementary Conditions and Division 01 Specification Sections, apply to this Section.

1.2 SUMMARY

- A. This Section includes unit ventilators and accessories with the following heating and cooling features:
 - 1. Hydronic heating coil.

1.3 DEFINITIONS

- A. BAS: Building automation system.
- B. HGBP: Hot-gas bypass.

1.4 SUBMITTALS

- A. Product Data: Include rated capacities, operating characteristics, and furnished specialties and accessories for each unit type and configuration.
- B. Shop Drawings: Detail equipment assemblies and indicate dimensions, weights, loads, required clearances, method of field assembly, components, and location and size of each field connection.
 - 1. Plans, elevations, sections, and details.
 - 2. Details of anchorages and attachments to structure and to supported equipment.
 - 3. Wiring Diagrams: Power, signal, and control wiring.
- C. Coordination Drawings: Reflected ceiling plans, drawn to scale, on which the following items are shown and coordinated with each other, based on input from installers of the items involved:
 - 1. Ceiling suspension components.
 - 2. Method of attaching hangers to building structure.
 - 3. Size and location of initial access modules for acoustical tile.
 - 4. Size and location of access panels in hard ceilings to provide access to concealed units.
 - 5. Items penetrating finished ceiling, including the following:
 - a. Lighting fixtures.

- b. Air outlets and inlets.
 - c. Sprinklers.
 - D. **Manufacturer Seismic Qualification Certification:** Submit certification that unit ventilators, accessories, and components will withstand seismic forces defined in Division 23 Section "Vibration Controls for HVAC." Include the following:
 - 1. **Basis for Certification:** Indicate whether withstand certification is based on actual test of assembled components or on calculation.
 - a. The term "withstand" means "the unit will remain in place without separation of any parts from the device when subjected to the seismic forces specified."
 - b. The term "withstand" means "the unit will remain in place without separation of any parts from the device when subjected to the seismic forces specified and the unit will be fully operational after the seismic event."
 - 2. **Dimensioned Outline Drawings of Equipment Unit:** Identify center of gravity and locate and describe mounting and anchorage provisions.
 - 3. **Detailed description of equipment anchorage devices on which the certification is based and their installation requirements.**
 - E. **Field quality-control test reports.**
 - F. **Operation and Maintenance Data:** For unit ventilators to include in emergency, operation, and maintenance manuals. In addition to items specified in Division 01 Section "Operation and Maintenance Data," include the following:
 - 1. **Maintenance schedules and repair part lists for motors, coils, integral controls, and filters.**
 - G. **Warranty:** Special warranty specified in this Section.
- 1.5 **QUALITY ASSURANCE**
- A. **Electrical Components, Devices, and Accessories:** Listed and labeled as defined in NFPA 70, Article 100, by a testing agency acceptable to authorities having jurisdiction, and marked for intended use.
 - B. **Comply with NFPA 70.**
 - C. **ASHRAE Compliance:** Applicable requirements in ASHRAE 62.1-2004, Section 5 - "Systems and Equipment" and Section 7 - "Construction and Startup."
 - D. **ASHRAE/IESNA 90.1-2004 Compliance:** Applicable requirements in ASHRAE/IESNA 90.1-2004, Section 6 - "Heating, Ventilating, and Air-Conditioning."

1.6 COORDINATION

- A. Coordinate layout and installation of unit ventilators and suspension system components with other construction that penetrates or is supported by ceilings, including light fixtures, HVAC equipment, fire-suppression-system components, and partition assemblies.
- B. Coordinate size and location of wall sleeves for outdoor-air intake and relief dampers.

1.7 WARRANTY

- A. Special Warranty: Manufacturer's standard form in which manufacturer agrees to repair or replace components of condensing units that fail in materials or workmanship within specified warranty period.
 - 1. Failures include, but are not limited to, the following:
 - a. Compressor failure.
 - b. Condenser coil leak.
 - 2. Warranty Period: Five years from date of Substantial Completion.

1.8 EXTRA MATERIALS

- A. Furnish extra materials described below that match products installed and that are packaged with protective covering for storage and identified with labels describing contents.
 - 1. Unit Ventilator Filters: Furnish spare filter(s) for each filter installed.

PART 2 - PRODUCTS

2.1 MANUFACTURERS

- A. Available Manufacturers: Subject to compliance with requirements, manufacturers offering products that may be incorporated into the Work include, but are not limited to, the following:
 - 1. Carrier Corporation.
 - 2. Daikin.
 - 3. Nesbitt Aire, Inc.; PEF Industries, Inc.
 - 4. Trane.

2.2 MANUFACTURED UNITS

- A. Description: Factory-packaged and -tested units rated according to ARI 840, ASHRAE 33, and UL 1995, including finished cabinet, filter, cooling coil, drain pan, supply-air fan and motor in blowthrough configuration, and hydronic cooling coil.

2.3 CABINETS

- A. Insulation: Minimum 1 1/2-inch thick, foil-covered, closed-cell foam complying with ASTM C 1071 and attached with adhesive complying with ASTM C 916.
 - 1. Fire-Hazard Classification: Insulation and adhesive shall have a combined maximum flame-spread index of 25 and smoke-developed index of 50 when tested according to ASTM E 84.
 - 2. Airstream Surfaces: Surfaces in contact with the airstream shall comply with requirements in ASHRAE 62.1-2004.
- B. Cabinet Frame and Access Panels: Welded-steel frame with removable panels fastened with hex-head tamperproof fasteners.
 - 1. Steel components exposed to moisture shall be hot-dip galvanized after fabrication.
- C. Cabinet Finish: Baked-on primer ready for field painting.
- D. Cabinet Finish: Baked enamel, in manufacturer's standard paint color as selected by Architect.
- E. Indoor-Supply-Air Grille: Aluminum double deflection, adjustable.
- F. Return-Air Inlet: Front toe space.
- G. End Panels: Matching material and finish of unit ventilator.
- H. Outdoor-Air Wall Box: Minimum 0.1265-inch thick, aluminum, rain-resistant louver and box with integral eliminators and bird screen.
 - 1. Louver Configuration: Horizontal rain-resistant louver.
 - 2. Louver Material: Aluminum, anodized, Color to match exiting.
 - 3. Bird Screen: 1/2-inch mesh screen on interior side of louver.

2.4 COILS

- A. Test and rate unit ventilator coils according to ASHRAE 33.
- B. Hydronic Coils: Copper tube, with mechanically bonded aluminum fins spaced no closer than 0.1 inch, rated for a minimum working pressure of 200 psig and a maximum entering-water temperature of 220 deg F. Include manual air vent and drain valve.

2.5 INDOOR FAN

- A. Fan and Motor Board: Removable.
 - 1. Fan: Forward curved, double width, centrifugal; directly connected to motor. Thermoplastic or painted-steel wheels; and aluminum, painted-steel, or galvanized-steel fan scrolls.

2. Fan Shaft and Bearings: Hollow steel shaft with permanently lubricated, resiliently mounted bearings.
3. Motor: Permanently lubricated, multispeed, resiliently mounted on motor board. Comply with requirements in Division 23 Section "Common Motor Requirements for HVAC Equipment."
4. Wiring Termination: Connect motor to chassis wiring with plug connection.

2.6 DAMPERS

- A. Mixing Dampers: Galvanized-steel blades with edge and end seals and nylon bearings; with electric actuator.
- B. Outdoor-Air Dampers: Galvanized-steel blades with edge and end seals and nylon bearings; with electric actuator.
- C. Comply with ASHRAE/IESNA 90.1-2004.

2.7 ACCESSORIES

- A. Subbase: Sheet metal floor-mounting base with leveling screws and black enamel finish.
- B. Insulated outdoor-air plenum.
 1. Insulation: Minimum 1-inch thick, foil-covered, closed-cell foam complying with ASTM C 1071 and attached with adhesive complying with ASTM C 916.
 - a. Fire-Hazard Classification: Insulation and adhesive shall have a combined maximum flame-spread index of 25 and smoke-developed index of 50 when tested according to ASTM E 84.
 - b. Airstream Surfaces: Surfaces in contact with the airstream shall comply with requirements in ASHRAE 62.1-2004.
- C. Return-air plenum, 6 inches thick, designed to take return air from top inlet grilles in cabinets on both sides of unit ventilator with gasket seals on wall and outdoor-air plenum extension.
- D. Duct flanges for supply-, return-, and outdoor-air connections.
- E. Filters: Minimum arrestance according to ASHRAE 52.1, and a minimum efficiency reporting value (MERV) according to ASHRAE 52.2.
 1. Glass Fiber Treated with Adhesive: 80 percent arrestance and 5 MERV.
 2. Pleated Cotton-Polyester Media: 90 percent arrestance and 7 MERV.

2.8 FACTORY HYDRONIC PIPING PACKAGE

- A. Piping: ASTM B 88, Type L (ASTM B 88M, Type B copper tube with wrought-copper fittings and brazed joints. Label piping to indicate service, inlet, and outlet. Crossover piping, NPS 1-1/2 with shutoff valves.

- B. Control Valves: Electric actuators compatible with terminal controller and building controls. (Provide pressure independent control valve where PICV valves are installed in the existing facility or provided by CCMS Subcontractor for other equipment on project).
- C. Isolation Valves, Strainers, Unions, and Balance Valves:
 - 1. Two-Piece Ball Valves: Bronze body with stainless-steel ball and stem and galvanized-steel lever handle for each supply and return connection. If balancing device is combination shutoff type with memory stop, isolation valve may be omitted on the return.
 - 2. Calibrated-Orifice Balancing Valves: Bronze body, ball type; 125-psig working pressure, 250 deg F maximum operating temperature; with calibrated orifice or venturi, connections for portable differential pressure meter with integral seals, threaded ends, and equipped with a memory stop to retain set position. (Not required where pressure independent control valve is installed).
 - 3. Automatic Flow-Control Valve: Brass or ferrous-metal body; 300-psig working pressure at 250 deg F, with removable, corrosion-resistant, tamperproof, self-cleaning piston spring; factory set to maintain constant indicated flow with plus or minus 10 percent over differential pressure range of 2 to 80 psig .
 - 4. Y-Pattern Hydronic Strainers: Cast-iron body (ASTM A 126, Class B); 125-psig working pressure; with threaded connections, bolted cover, perforated stainless-steel basket, and bottom drain connection. Include minimum NPS 1/2 hose-end, full-port, ball-type blowdown valve in drain connection.
 - 5. Wrought-Copper Unions: ASME B16.22.
 - 6. Valve Packs with half unions are not acceptable. Provide full unions.

2.9 BASIC UNIT CONTROLS

- A. Control devices and operational sequences are specified in Division 23 Sections "Direct Digital Control (DDC) for HVAC."
- B. Basic Unit Controls:
 - 1. Control voltage transformer.
 - 2. Wall-mounting thermostat with the following features.
 - a. Heat- off switch.
 - b. Fan on-auto switch.
 - c. Adjustable deadband.
 - d. Exposed set point.
 - e. Exposed indication.
 - f. Degree F indication.
 - 3. DDC Controls as indicated.
 - a. Input data includes room temperature and humidity set points, and occupied and unoccupied periods.
 - b. Output data includes room temperature and humidity, supply-air temperature, entering-water temperature, operating mode, and status.

2.10 CAPACITIES AND CHARACTERISTICS

- A. Fan: As indicated.
- B. Cooling Capacity: As indicated on drawings
- C. Chilled-Water Coil: As indicated on drawings.
- D. Heating Capacity: As indicated.
- E. Filters:
 - 1. Type: Pleated cotton-polyester media.
 - 2. Maximum Face Velocity: 200 fpm.
 - 3. Thickness: As indicated.
- F. Electrical Characteristics for Single-Point Connection: As indicated on drawings.

PART 3 - EXECUTION

3.1 EXAMINATION

- A. Examine areas to receive unit ventilators for compliance with requirements for installation tolerances and other conditions affecting performance.
- B. Examine roughing-in for piping and electrical connections to verify actual locations before unit ventilator installation.
- C. Proceed with installation only after unsatisfactory conditions have been corrected.

3.2 INSTALLATION

- A. Install unit ventilators to comply with NFPA 90A.
- B. Suspend horizontal unit ventilators from structure with threaded steel rods and minimum 1.0-inch static-deflection spring hangers. Vibration isolators are specified in Division 23 Section "Vibration Controls for HVAC."
- C. Verify location of thermostats, humidistat's, and other exposed control sensors with Drawings and room details before installation. Install devices 48 inches,60 inches above finished floor.
- D. Refer to Division 23 Section "Refrigerant Piping" for condensing units matched to refrigerant cooling coil packaged in unit ventilators.

3.3 CONNECTIONS

- A. Piping installation requirements are specified in other Division 23 Sections. Drawings indicate general arrangement of piping, fittings, and specialties. Specific connection requirements are as follows:
 - 1. Install piping adjacent to machine to allow service and maintenance.
 - 2. Connect piping to unit ventilator factory hydronic piping package. Install piping package if shipped loose.
 - 3. Connect condensate drain to storm drain or grade.
- B. Install refrigerant piping as required by Division 23 Section "Refrigerant Piping," and add refrigerant as required to compensate for length of piping.
- C. Connect supply and return ducts to unit ventilators with flexible duct connectors specified in Division 23 Section "Air Duct Accessories." Comply with safety requirements in UL 1995 for duct connections.
- D. Ground equipment according to Division 26 Section "Grounding and Bonding for Electrical Systems."
- E. Connect wiring according to Division 26 Section "Low-Voltage Electrical Power Conductors and Cables."

3.4 FIELD QUALITY CONTROL

- A. Manufacturer's Field Service: Engage a factory-authorized service representative to inspect, test, and adjust field-assembled components and equipment installation, including connections, and to assist in field testing. Report results in writing.
- B. Perform the following field tests and inspections and prepare test reports:
 - 1. Operational Test: After electrical circuitry has been energized, start units to confirm proper motor rotation and unit operation.
 - 2. Operate heating coil through full range of operation.
 - 3. Test and adjust controls and safety devices. Replace damaged and malfunctioning controls and equipment.
- C. Remove and replace malfunctioning units and retest as specified above.

3.5 ADJUSTING

- A. Adjust initial temperature set points.

3.6 DEMONSTRATION

- A. Engage a factory-authorized service representative to train Owner's maintenance personnel to adjust, operate, and maintain unit ventilators. Refer to Division 01 Section "Demonstration and Training."

END OF SECTION 238223

SECTION 238233 - CONVECTORS

PART 1 - GENERAL

1.1 RELATED DOCUMENTS

- A. Drawings and general provisions of the Contract, including General and Supplementary Conditions and other Division 01 Specification Sections, apply to this Section.

1.2 SUMMARY

- A. This Section includes the following:

1. Hydronic baseboard radiators.
2. Hydronic finned-tube radiators.
3. Hydronic convectors.
4. Flat-pipe steel radiators.

1.3 SUBMITTALS

- A. Product Data: Include rated capacities, operating characteristics, furnished specialties, and accessories for each type of product indicated.
- B. Shop Drawings: Detail equipment assemblies and indicate dimensions, weights, loads, required clearances, method of field assembly, components, and location and size of each field connection.
 1. Plans, elevations, sections, and details.
 2. Details of custom-fabricated enclosures indicating dimensions.
 3. Location and size of each field connection.
 4. Location and arrangement of piping valves and specialties.
 5. Location and arrangement of integral controls.
 6. Enclosure joints, corner pieces, access doors, and other accessories.
 7. Wiring Diagrams: Power, signal, and control wiring.
- C. Coordination Drawings: Floor plans and other details, drawn to scale, on which the following items are shown and coordinated with each other, based on input from installers of the items involved:
 1. Structural members, including wall construction, to which convection units will be attached.
 2. Method of attaching convection units to building structure.
 3. Penetrations of fire-rated wall and floor assemblies.
- D. Color Samples for Initial Selection: For units with factory-applied color finishes.

- E. Color Samples for Verification: For each type of exposed finish required.
- F. Field quality-control test reports.
- G. Operation and Maintenance Data: For convection heating units to include in emergency, operation, and maintenance manuals.

1.4 QUALITY ASSURANCE

- A. Electrical Components, Devices, and Accessories: Listed and labeled as defined in NFPA 70, Article 100, by a testing agency acceptable to authorities having jurisdiction, and marked for intended use.

PART 2 - PRODUCTS

2.1 HOT-WATER BASEBOARD RADIATORS

- A. Basis-of-Design Product: Subject to compliance with requirements, provide the product indicated on Drawings or an approved equal. Acceptable manufacturers include but are not limited to the following:
 - 1. Embassy Industries, Inc.
 - 2. Haydon Corporation, Inc.
 - 3. Rittling, a div. of Hydro-Air Components.
 - 4. Rosemex.
 - 5. Slant/Fin.
- B. Performance Ratings: Rate baseboard radiators according to Hydronics Institute's "I=B=R Testing and Rating Standard for Baseboard Radiation."
- C. Heating Elements: Copper tubing mechanically expanded into flanged collars of evenly spaced aluminum fins resting on polypropylene element glides. One end of tube shall be belled.
 - 1. Tube Diameter: NPS 1/2.
 - 2. Fin Size: 2-1/2 by 2-1/2 inches.
 - 3. Fin Spacing: 58 per foot.
 - 4. Entering Air Temperature: 65 deg F.
 - 5. Average Water Temperature: 180 deg F.
 - 6. Minimum Water Velocity: 1/2 fps.
 - 7.
- D. Enclosures: Minimum 0.0329-inch- or 0.0428-inch- thick steel, removable front cover.
- E. Rust-Resistant Enclosures: Minimum 0.052-inch- thick ASTM A 653/A 653M, G60 galvanized-steel, removable front cover.
 - 1. Full-height back.

2. Full-length damper.
3. End panel.
4. End caps.
5. Inside and outside corners.
6. Valve access door.
7. Joiner pieces to snap together.
8. Finish: Baked-enamel finish in manufacturer's standard color as selected by Architect.
9. Element Brackets: Primed and painted steel to support front panel and element.

2.2 HOT-WATER FINNED-TUBE RADIATORS

- A. Basis-of-Design Product: Subject to compliance with requirements, provide the product indicated on Drawings or an approved equal. Acceptable manufacturer's include but are not limited to the following:
1. Embassy Industries, Inc.
 2. Engineered Air.
 3. Rittling, a div. of Hydro-Air Components.
 4. Rosemex.
 5. Slant/Fin.
 6. Trane.
- B. Performance Ratings: Rate finned-tube radiators according to Hydronics Institute's "I=B=R Testing and Rating Standard for Finned-Tube (Commercial) Radiation."
- C. Heating Elements: Copper tubing mechanically expanded into flanged collars of evenly spaced aluminum fins resting on element supports. One tube end shall be belled.
1. Tube Diameter: NPS 3/4.
 2. Fin Size: 3 by 3 inches.
 3. Fin Spacing: 50 per foot.
 4. Entering Air Temperature: 65 deg F.
 5. Average Water Temperature: 180 deg F.
 6. Minimum Water Velocity: 1/2 fps.
- D. Element Supports: Ball-bearing cradle type to permit longitudinal movement on enclosure brackets.
- E. Front Panel: Minimum 0.0428-inch-thick steel.
- F. Rust-Resistant Front Panel: Minimum 0.052-inch-thick, ASTM A 653/A 653M, G60 galvanized steel.
- G. Wall-Mounting Back Panel: Minimum 0.0329-inch-thick steel, full height, with full-length channel support for front panel without exposed fasteners.
- H. Floor-Mounting Pedestals: Conceal insulated piping at maximum 36-inch spacing. Pedestal-mounting back panel shall be solid panel matching front panel. Provide stainless-steel escutcheon for floor openings at pedestals.

- I. Support Brackets: Locate at maximum 36-inch spacing to support front panel and element.
- J. Finish: Baked-enamel finish in manufacturer's standard color as selected by Architect.
- K. Damper: Knob-operated internal damper at enclosure outlet.
- L. Access Doors: Factory made, permanently hinged with tamper-resistant fastener, minimum size 6 by 7 inches, integral with enclosure.
- M. Enclosure Style:
 - 1. Front Inlet Grille: Punched louver; painted to match enclosure.
 - 2. Front Inlet Grille: Extruded-aluminum linear bar grille; pencil-proof bar spacing.
 - a. Mill-finish aluminum.
 - b. Anodized finish, color as selected by Architect from manufacturer's standard colors.
 - c. Painted to match enclosure.
 - 3. Outlet Grille: Punched louver; painted to match enclosure.
 - 4. Outlet Grille: Extruded-aluminum linear bar grille; pencil-proof bar spacing.
 - a. Mill-finish aluminum.
 - b. Anodized finish, color as selected by Architect from manufacturer's standard colors.
 - c. Painted to match enclosure.
- N. Accessories: Filler sections, corners, relay sections, and splice plates all matching the enclosure and grille finishes.

2.3 HOT-WATER CONVECTORS

- A. Basis-of-Design Product: Subject to compliance with requirements, provide the product indicated on Drawings or a comparable product by one of the following:
 - 1. Engineered Air.
 - 2. Rosemex.
 - 3. Slant/Fin.
 - 4. Trane.
- B. Convector Elements: Seamless copper tubing mechanically expanded into evenly spaced aluminum fins and rolled into cast-iron or brass headers with inlet/outlet and air vent; steel side plates and supports. Factory-pressure-test element at minimum 100 psig.

For capacities and characteristics see equipment schedule on Mechanical Drawings.
- C. Front and Top Panel: Minimum 0.0528-inch-thick steel with exposed corners rounded; removable front panels with tamper-resistant fasteners braced and reinforced for stiffness.

- D. Wall-Mounting Back and End Panels: Minimum 0.0428-inch-thick steel.
- E. Floor-Mounting Pedestals: Conceal conduit for power and control wiring at maximum 36-inch spacing. Pedestal-mounting back panel shall be solid panel matching front panel.
- F. Support Brackets: Locate at maximum 36-inch spacing to support front panel and element.
- G. Insulation: 1/2-inch-thick, fibrous glass on inside of the back of the enclosure.
- H. Finish: Baked-enamel finish in manufacturer's standard color as selected by Architect.
- I. Damper: Knob-operated internal damper.
- J. Access Doors: Factory made, permanently hinged with tamper-resistant fastener, minimum size 6 by 7 inches, integral with enclosure.
- K. Enclosure Style: Sloped top.
 - 1. Front Inlet Grille: Punched louver; painted to match enclosure.
 - 2. Front Inlet Grille: Extruded-aluminum linear bar grille; pencil-proof bar spacing.
 - a. Mill-finish aluminum.
 - b. Anodized finish, color as selected by Architect from manufacturer's standard colors.
 - c. Painted to match enclosure.
 - 3. Top or Front Outlet Grille: Punched louver; painted to match enclosure.
 - 4. Top or Front Outlet Grille: Extruded-aluminum linear bar grille; pencil-proof bar spacing.
 - a. Mill-finish aluminum.
 - b. Anodized finish, color as selected by Architect from manufacturer's standard colors.
 - c. Painted to match enclosure.

PART 3 - EXECUTION

3.1 EXAMINATION

- A. Examine areas to receive convection heating units for compliance with requirements for installation tolerances and other conditions affecting performance.
- B. Examine roughing-in for hydronic-piping connections to verify actual locations before convection heating unit installation.
- C. Proceed with installation only after unsatisfactory conditions have been corrected.

3.2 CONVECTOR INSTALLATION

- A. Install units level and plumb.
- B. Install valves within reach of access door provided in enclosure.
- C. Install air-seal gasketing between wall and recessing flanges or front cover of fully recessed unit.
- D. Install piping within pedestals for freestanding units.

3.3 CONNECTIONS

- A. Piping installation requirements are specified in Division 23 Section "Hydronic Piping." Drawings indicate general arrangement of piping, fittings, and specialties.
- B. Connect hot-water units and components to piping according to Division 23 Section "Hydronic Piping."
 - 1. Install shutoff valves on inlet and outlet, and balancing valve on outlet.
- C. Connect steam units and components to piping according to Division 23 Section "Steam and Condensate Heating Piping."
 - 1. Install shutoff valve on inlet; install strainer, steam trap, and shutoff valve on outlet.
- D. Install control valves as required by Division 23 Section "Direct Digital Control (DDC) for HVAC."
- E. Install piping adjacent to convection heating units to allow service and maintenance.
- F. Ground electric convection heating units according to Division 26 Section "Grounding and Bonding for Electrical Systems."
- G. Connect wiring according to Division 26 Section "Low-Voltage Electrical Power Conductors and Cables."

3.4 FIELD QUALITY CONTROL

- A. Perform the following field tests and inspections and prepare test reports:
 - 1. Leak Test: After installation, charge system and test for leaks. Repair leaks and retest until no leaks exist.
 - 2. Operational Test: After electrical circuitry has been energized, start units to confirm proper convection heating unit operation.
 - 3. Test and adjust controls and safeties. Replace damaged and malfunctioning controls and equipment.

- B. Remove and replace convection heating units that do not pass tests and inspections and retest as specified above.

END OF SECTION 238233

SECTION 238239 - UNIT HEATERS

PART 1 - GENERAL

1.1 RELATED DOCUMENTS

- A. Drawings and general provisions of the Contract, including General and Supplementary Conditions and Division 01 Specification Sections, apply to this Section.

1.2 SUMMARY

- A. Section Includes:
 - 1. Cabinet unit heaters with centrifugal fans and hot-water electric-resistance heating coils.
 - 2. Propeller unit heaters with hot-water electric-resistance heating coils.
 - 3. Wall and ceiling heaters with propeller fans and electric-resistance heating coils.

1.3 DEFINITIONS

- A. BAS: Building automation system.
- B. CWP: Cold working pressure.
- C. PTFE: Polytetrafluoroethylene plastic.
- D. TFE: Tetrafluoroethylene plastic.

1.4 SUBMITTALS

- A. Product Data: Include rated capacities, operating characteristics, furnished specialties, and accessories for each product indicated.
- B. Shop Drawings: Detail equipment assemblies and indicate dimensions, weights, loads, required clearances, method of field assembly, components, and location and size of each field connection.
 - 1. Plans, elevations, sections, and details.
 - 2. Location and size of each field connection.
 - 3. Details of anchorages and attachments to structure and to supported equipment.
 - 4. Equipment schedules to include rated capacities, operating characteristics, furnished specialties, and accessories.
 - 5. Location and arrangement of piping valves and specialties.
 - 6. Location and arrangement of integral controls.
 - 7. Wiring Diagrams: Power, signal, and control wiring.

- C. Coordination Drawings: Floor plans, reflected ceiling plans, and other details, drawn to scale, on which the following items are shown and coordinated with each other, based on input from installers of the items involved:
 - 1. Suspended ceiling components.
 - 2. Structural members to which unit heaters will be attached.
 - 3. Method of attaching hangers to building structure.
 - 4. Size and location of initial access modules for acoustical tile.
 - 5. Items penetrating finished ceiling, including the following:
 - a. Lighting fixtures.
 - b. Air outlets and inlets.
 - c. Speakers.
 - d. Sprinklers.
 - e. Access panels.
 - 6. Perimeter moldings for exposed or partially exposed cabinets.
- D. Samples for Initial Selection: Finish colors for units with factory-applied color finishes.
- E. Samples for Verification: Finish colors for each type of cabinet unit heater and wall and ceiling heaters indicated with factory-applied color finishes.
- F. Manufacturer Seismic Qualification Certification: Submit certification that cabinet unit heaters, accessories, and components will withstand seismic forces defined in Division 23 Section "Vibration and Seismic Controls for HVAC Piping and Equipment." Include the following:
 - 1. Basis for Certification: Indicate whether withstand certification is based on actual test of assembled components or on calculation.
 - a. The term "withstand" means "the unit will remain in place without separation of any parts from the device when subjected to the seismic forces specified."
 - b. The term "withstand" means "the unit will remain in place without separation of any parts from the device when subjected to the seismic forces specified and the unit will be fully operational after the seismic event."
 - 2. Dimensioned Outline Drawings of Equipment Unit: Identify center of gravity and locate and describe mounting and anchorage provisions.
 - 3. Detailed description of equipment anchorage devices on which the certification is based and their installation requirements.
- G. Field quality-control test reports.
- H. Operation and Maintenance Data: For cabinet unit heaters to include in emergency, operation, and maintenance manuals.

1.5 QUALITY ASSURANCE

- A. Electrical Components, Devices, and Accessories: Listed and labeled as defined in NFPA 70, Article 100, by a testing agency acceptable to authorities having jurisdiction, and marked for intended use.
- B. ASHRAE Compliance: Applicable requirements in ASHRAE 62.1-2004, Section 5 - "Systems and Equipment" and Section 7 - "Construction and Startup."
- C. ASHRAE/IESNA 90.1-2004 Compliance: Applicable requirements in ASHRAE/IESNA 90.1-2004, Section 6 - "Heating, Ventilating, and Air-Conditioning."

PART 2 - PRODUCTS

2.1 CABINET UNIT HEATERS

- A. Manufacturers: Subject to compliance with requirements, provide products by one of the following:
 - 1. Airtherm; a Mestek Company.
 - 2. Dunham-Bush, Inc.
 - 3. Engineered Air Ltd.
 - 4. Indeeco.
 - 5. International Environmental Corporation.
 - 6. Markel Products; a division of TPI Corporation.
 - 7. Marley Electric Heating; a division of Marley Engineered Products.
 - 8. Rosemex Products.
 - 9. Trane.
 - 10. USA Coil & Air.
- B. Description: A factory-assembled and -tested unit complying with ARI 440.
 - 1. Comply with UL 2021.
- C. Coil Section Insulation: ASTM C 1071; surfaces exposed to airstream shall be corrosion-resistant coating to prevent erosion of glass fibers.
 - 1. Thickness: 1/2 inch.
 - 2. Fire-Hazard Classification: Maximum flame-spread index of 25 and smoke-developed index of 50 when tested according to ASTM E 84.
 - 3. Adhesive: Comply with ASTM C 916 and with NFPA 90A or NFPA 90B.
 - 4. Airstream Surfaces: Surfaces in contact with the airstream shall comply with requirements in ASHRAE 62.1-2004.
- D. Coil Section Insulation: Comply with NFPA 90A or NFPA 90B. Unicellular polyethylene thermal plastic, preformed sheet insulation complying with ASTM C 534, Type II, except for density.

1. Thickness: 1/2 inch.
 2. Thermal Conductivity (k-Value): 0.24 Btu x in./h x sq. ft. at 75 deg F mean temperature.
 3. Fire-Hazard Classification: Maximum flame-spread index of 25 and smoke-developed index of 50 when tested according to ASTM C 411.
 4. Adhesive: As recommended by insulation manufacturer and complying with NFPA 90A or NFPA 90B.
 5. Airstream Surfaces: Surfaces in contact with the airstream shall comply with requirements in ASHRAE 62.1-2004.
- E. Cabinet: Steel with baked-enamel finish with manufacturer's standard paint, in color selected by Architect.
1. Vertical Unit, Exposed Front Panels: Minimum 0.0528-inch- thick, galvanized, sheet steel, removable panels with channel-formed edges secured with tamperproof cam fasteners.
 2. Horizontal Unit, Exposed Bottom Panels: Minimum 0.0528-inch- - thick, galvanized, sheet steel, removable panels secured with tamperproof cam fasteners and safety chain.
 3. Recessing Flanges: Steel, finished to match cabinet.
 4. Control Access Door: Key operated.
 5. Extended Piping Compartment: 8-inch- wide piping end pocket.
 6. False Back: Minimum 0.0428-inch thick steel, finished to match cabinet.
- F. Filters: Minimum arrestance according to ASHRAE 52.1 and a minimum efficiency reporting value (MERV) according to ASHRAE 52.2.
1. Washable Foam: 70 percent arrestance and 3 MERV.
 2. Glass Fiber Treated with Adhesive: 80 percent arrestance and 5 MERV.
 3. Pleated: 90 percent arrestance and 7 MERV.
- G. Hot-Water Coil: Copper tube, with mechanically bonded aluminum fins spaced no closer than 0.1 inch and rated for a minimum working pressure of 200 psig and a maximum entering-water temperature of 220 deg F. Include manual air vent and drain.
- H. Electric-Resistance Heating Coil: Nickel-chromium heating wire, free from expansion noise and hum, mounted in ceramic inserts in a galvanized-steel housing; with fuses in terminal box for overcurrent protection and limit controls for high-temperature protection. Terminate elements in stainless-steel machine-staked terminals secured with stainless-steel hardware.
- I. Fan and Motor Board: Removable.
1. Fan: Forward curved, double width, centrifugal; directly connected to motor. Thermoplastic or painted-steel wheels, and aluminum, painted-steel, or galvanized-steel fan scrolls.
 2. Motor: Permanently lubricated, multispeed; resiliently mounted on motor board. Comply with requirements in Division 23 Section "Common Motor Requirements for HVAC Equipment."
 3. Wiring Terminations: Connect motor to chassis wiring with plug connection.
- J. Control devices and operational sequences are specified in Division 23 Sections "Direct Digital Control (DDC) system for HVAC"

K. Basic Unit Controls:

1. Control voltage transformer.
2. Wall-mounting thermostat with the following features.
 - a. Heat-off switch.
 - b. Fan on-auto switch.
 - c. Manual fan speed switch.
 - d. Adjustable deadband.
 - e. Deg F indication.
3. Wall-mounting or Unit-mounted temperature sensor.
4. Unoccupied period override push button.
5. Data entry and access port.
 - a. Input data includes room temperature, and occupied and unoccupied periods.
 - b. Output data includes room temperature, supply-air temperature, entering-water temperature, operating mode, and status.

L. Electrical Connection: Factory wire motors and controls for a single field connection.

M. Capacities and Characteristics: see equipment schedule on Mechanical Drawings.

2.2 PROPELLER UNIT HEATERS

- A. Manufacturers: Subject to compliance with requirements, provide products by one of the following:
1. Airtherm; a Mestek Company.
 2. Engineered Air Ltd.
 3. McQuay International.
 4. Rosemex Products.
 5. Ruffneck Heaters; a division of Lexa Corporation.
 6. Trane.
- B. Description: An assembly including casing, coil, fan, and motor in vertical or horizontal discharge configuration with adjustable discharge louvers.
- C. Comply with UL 2021.
- D. Comply with UL 823.
- E. Cabinet: Removable panels for maintenance access to controls.
- F. Cabinet Finish: Manufacturer's standard baked enamel applied to factory-assembled and -tested propeller unit heater before shipping.
- G. Airstream Surfaces: Surfaces in contact with the airstream shall comply with requirements in ASHRAE 62.1-2004.

- H. Discharge Louver: Adjustable fin diffuser for horizontal units and conical diffuser for vertical units.
- I. General Coil Requirements: Test and rate hot-water propeller unit heater coils according to ASHRAE 33.
- J. Hot-Water Coil: Copper tube, minimum 0.025-inch wall thickness, with mechanically bonded aluminum fins spaced no closer than 0.1 inch and rated for a minimum working pressure of 200 psig and a maximum entering-water temperature of 325 deg F, with manual air vent. Test for leaks to 350 psig underwater.
- K. Electric-Resistance Heating Elements: Nickel-chromium heating wire, free from expansion noise and 60-Hz hum, embedded in magnesium oxide refractory and sealed in steel or corrosion-resistant metallic sheath with fins no closer than 0.16 inch. Element ends shall be enclosed in terminal box. Fin surface temperature shall not exceed 550 deg F at any point during normal operation.
 - 1. Circuit Protection: One-time fuses in terminal box for overcurrent protection and limit controls for high-temperature protection of heaters.
 - 2. Wiring Terminations: Stainless-steel or corrosion-resistant material.
- L. Fan: Propeller type with aluminum wheel directly mounted on motor shaft in the fan venturi.
- M. Fan Motors: Comply with requirements in Division 23 Section "Common Motor Requirements for HVAC Equipment."
 - 1. Motor Type: Permanently lubricated, multispeed.
- N. Control Devices:
 - 1. Unit-mounted or Wall-mounting thermostat.
- O. Capacities and Characteristics: see equipment schedule on Mechanical Drawings.

2.3 WALL AND CEILING HEATERS

- A. Available Manufacturers: Subject to compliance with requirements, manufacturers offering products that may be incorporated into the Work include, but are not limited to, the following:
- B. Manufacturers: Subject to compliance with requirements, provide products by one of the following:
- C. Basis-of-Design Product: Subject to compliance with requirements, provide the product indicated on Drawings or a comparable product by one of the following:
 - 1. Berko Electric Heating; a division of Marley Engineered Products.
 - 2. Chromalox, Inc.; a division of Emerson Electric Company.
 - 3. Indeeco.
 - 4. Markel Products; a division of TPI Corporation.
 - 5. Marley Electric Heating; a division of Marley Engineered Products.

6. Ouellet Canada Inc.
 7. QMark Electric Heating; a division of Marley Engineered Products.
 8. Trane.
- D. Description: An assembly including chassis, electric heating coil, fan, motor, and controls. Comply with UL 2021.
- E. Cabinet:
1. Front Panel: Extruded-aluminum bar grille, with removable panels fastened with tamperproof fasteners.
 2. Finish: Baked enamel over baked-on primer with manufacturer's standard color selected by Architect, applied to factory-assembled and -tested wall and ceiling heaters before shipping.
 3. Airstream Surfaces: Surfaces in contact with the airstream shall comply with requirements in ASHRAE 62.1-2004.
- F. Surface-Mounting Cabinet Enclosure: Steel with finish to match cabinet.
- G. Electric-Resistance Heating Coil: Nickel-chromium heating wire, free from expansion noise and hum, embedded in magnesium oxide refractory and sealed in corrosion-resistant metallic sheath. Terminate elements in stainless-steel, machine-staked terminals secured with stainless-steel hardware, and limit controls for high temperature protection. Provide integral circuit breaker for overcurrent protection.
- H. Fan: Aluminum propeller directly connected to motor.
1. Motor: Permanently lubricated. Comply with requirements in Division 23 Section "Common Motor Requirements for HVAC Equipment."
- I. Controls: Unit-mounted thermostat.
- J. Electrical Connection: Factory wire motors and controls for a single field connection.
- K. Capacities and Characteristics: see equipment schedule on Mechanical Drawings.

PART 3 - EXECUTION

3.1 EXAMINATION

- A. Examine areas to receive unit heaters for compliance with requirements for installation tolerances and other conditions affecting performance.
- B. Examine roughing-in for piping and electrical connections to verify actual locations before unit heater installation.
- C. Proceed with installation only after unsatisfactory conditions have been corrected.

3.2 INSTALLATION

- A. Install wall boxes in finished wall assembly; seal and weatherproof. Joint-sealant materials and applications are specified in Division 07 Section "Joint Sealants."
- B. Install cabinet unit heaters to comply with NFPA 90A.
- C. Install propeller unit heaters level and plumb.
- D. Suspend propeller unit heaters from structure with all-thread hanger rods and elastomeric hangers. Hanger rods and attachments to structure are specified in Division 23 Section "Hangers and Supports for HVAC Piping and Equipment." Vibration hangers are specified in Division 23 Section "Vibration and Seismic Controls for HVAC Piping and Equipment."
- E. Install wall-mounting thermostats and switch controls in electrical outlet boxes at heights to match lighting controls. Verify location of thermostats and other exposed control sensors with Drawings and room details before installation.
- F. Install new filters in each fan-coil unit within two weeks of Substantial Completion.

3.3 CONNECTIONS

- A. Piping installation requirements are specified in other Division 23 Sections. Drawings indicate general arrangement of piping, fittings, and specialties.
- B. Install piping adjacent to machine to allow service and maintenance.
- C. Connect piping to cabinet unit heater's factory, hot-water piping package. Install the piping package if shipped loose.
- D. Connect supply and return ducts to cabinet unit heaters with flexible duct connectors specified in Division 23 Section "Air Duct Accessories."
- E. Comply with safety requirements in UL 1995.
- F. Unless otherwise indicated, install union and gate or ball valve on supply-water connection and union and calibrated balancing valve on return-water connection of unit heater. Hydronic specialties are specified in Division 23 Section "Hydronic Piping."
- G. Unless otherwise indicated, install union and gate or ball valve on steam-supply connection and union, strainer, steam trap, and gate or ball valve on condensate-return connection of unit heater. Steam specialties are specified in Division 23 Section "Steam and Condensate Heating Piping."
- H. Ground equipment according to Division 26 Section "Grounding and Bonding for Electrical Systems."
- I. Connect wiring according to Division 26 Section "Low-Voltage Electrical Power Conductors and Cables."

3.4 FIELD QUALITY CONTROL

- A. Perform the following field tests and inspections and prepare test reports:
 - 1. Operational Test: After electrical circuitry has been energized, start units to confirm proper motor rotation and unit operation.
 - 2. Operate electric heating elements through each stage to verify proper operation and electrical connections.
 - 3. Test and adjust controls and safety devices. Replace damaged and malfunctioning controls and equipment.
- B. Remove and replace malfunctioning units and retest as specified above.

3.5 ADJUSTING

- A. Adjust initial temperature set points.

3.6 DEMONSTRATION

- A. Engage a factory-authorized service representative to train Owner's maintenance personnel to adjust, operate, and maintain cabinet unit heaters. Refer to Division 01 Section "Demonstration and Training."

END OF SECTION 238239