

SECTION 33 63 00 UNDERGROUND THERMAL ENERGY DISTRIBUTION PIPING AND
MANHOLES

PART 1 GENERAL

1.1 SCOPE OF THIS SECTION

- A. This section describes underground steam distribution and condensate return piping.

1.2 SECTION INCLUDES

- A. Manufactured, pre-insulated, pre-fabricated Drainable, Dryable, Testable piping
- B. Manufactured, pre-insulated, pre-fabricated piping
- C. Pipe Anchors.
- D. Piping in Manholes.
- E. Piping Insulation in Manholes.
- F. Manholes – Precast Concrete.
- G. Manholes and accessories.

1.3 QUALITY ASSURANCE: Comply with:

- A. ASME B31.1.
- B. ASME Section IX: Welding Materials and Procedures.
- C. AWS Certified Welder Certification: Certified at an AWS Testing facility in accordance with test standard QC7, Standard for AWS Certified Welders.

1.4 Informational Submittals:

- A. Coordination Drawings: Piping Layout, drawn to scale, on which the following items are shown and coordinated with each other using input from installers of the items involved:
 - 1. Suspended ceiling components.
 - 2. Other building services.
 - 3. Structural members.
- B. Qualification Data: For Installer.
 - 1. Welding Certificates:
 - a. Certify that field tests have been performed and that work meets or exceeds specified requirements.
 - b. Welder's certification.
 - c. Manufacturer's certificate that conduit system has been installed in accordance with recommended procedures.
 - 2. Field Quality Control Reports.
 - a. Radiographic report and films of welds.

- b. Carrier pipe pressure test report
- c. Conduit pipe pressure test report

3. Project Record Documents: Accurately record locations of pipe runs and invert elevations.

1.5 DELEGATED DESIGN

- A. The pre-insulated pipe manufacturer is to design and layout the system, including plan and elevation views, showing anchors, expansion provisions, building and manhole entrance details. Means for expansion must be made in pipe offsets or loops unless this is compensated for integrally in the system.
- B. The pre-insulated pipe manufacturer must engage with a professional engineer or the engineer of record to perform analysis of entire pipe system from anchor to anchor.
- C. A licensed engineer is to design the piping systems in accordance with ASME B31.1, latest edition and stamped by a professional engineer. System layout will be analyzed by a licensed engineer to determine stresses, strains and movements of the service pipe. Analysis of stresses, strains and movements must be performed along entire pipe system from anchor to anchor.

1.6 QUALITY ASSURANCE

- A. Installer Qualifications:
- B. Steel Support Welding: Qualify procedures and personnel according to AWS D1.1/D1.1M, "Structural Welding Code - Steel."
- C. Delegated-Design Submittal:
 - 1. Design calculations and detailed fabrication and assembly of pipe anchors and alignment guides, hangers and supports for multiple pipes, expansion joints and loops, and attachments of the same to the building structure. Professional Engineering stamp required for anchors and expansion loops.
 - 2. Locations of pipe anchors and alignment guides and expansion joints and loops. Size and design of concrete blocks.
 - 3. Locations of and details for penetrations, including sleeves and sleeve seals for exterior walls, floors, basement, and foundation walls.
 - 4. Locations of and details for penetration and firestopping for fire- and smoke-rated wall and floor and ceiling assemblies.
- D. Pipe Welding: Qualify procedures and operators according to the following:
 - 1. ASME Compliance: Comply with ASME B31.1, "Power Piping," for materials, products, and installation for Steam piping.
 - 2. Certify that each welder has passed AWS qualification tests for welding processes involved and that certification is current.

1.7 SUBMITTALS

- A. Shop Drawings:
 - 1. Underground Piping: Show plans, profiles and sections at scale not less than 1/8 inch to a foot. Indicate electrical conduits and structural elements including foundation walls

and other elements affecting routing within 5'-0" of piping system.

2. Provide detailed plans and sections of manholes and piping with related accessories within manholes.
3. Expansion Loops and Bends: Demonstrate with calculations that pipe stresses from temperature changes are within the allowable requirements in ASME B31.1 and that the anchors and the guides will withstand the resultant forces. Detailed design layout drawings shall include all analysis node points. As a minimum, computer analysis results shall include node stresses, forces, moments and displacements. Calculations shall be stamped by a registered Professional Engineer in the employ of the DDT manufacturer. Cold springing is acceptable but shall not be factored in to stress analysis.
4. Furnish thermal expansion calculations for the steam and condensate piping using the design characteristics indicated in this section and installation temperature no higher than the ambient temperature at the site (14 degrees F).

1.8 DELIVERY, STORAGE AND HANDLING: Follow Section 01600.

- A. Store valves in shipping containers with labeling in place.
- B. Protect flange faces from damage with wood, plastic or soft metal.
- C. Protect carrier pipe open ends from rain and debris.

PART 2 PRODUCTS

2.1 MANUFACTURED PREFABRICATED, PREINSULATED DRAINABLE, DRYABLE, TESTABLE CONDUIT PIPING SYSTEM

- A. Assembly is to be rated for temperatures up to 750 deg F.
- B. Manufacturers:
 1. PERMA-PIPE Multi-Therm 750.
 2. Thermacor Process, LLC., Duo-Therm 505.
 3. Rovanco High Temp Conduit Elite
 4. Other manufacturers are not permitted.

C. SERVICE PIPE

1. Internal service piping to be Schedule 40 carbon steel, seamless, ASTM A53, Type S.
2. Joints are to be butt-welded for sizes 2-1/2 inches and larger, and socket welded for 2 inches and below.
3. End seals, gland seals and anchors shall be factory fabricated to prevent the ingress of moisture into the system.

D. SERVICE PIPE INSULATION

1. Service Pipe Insulation Shall be one of the following:
2. Mineral Wool.
3. Silica Aerogel, high temperature insulation blanked, reinforced with non-woven, glass fiber batting, held in place by stainless steel bands or stables.

E. CONDUIT PIPING

1. Conduit piping is to be 10-gauge, welded, smooth-wall black steel conforming to ASTM A-211, A-139, A-134, and A-135. Conduit shall be tested at the factory to insure air and watertight welds prior to any fabrication or application of coating.

F. CONDUIT PIPE INSULATION

1. Conduit System Insulation: Minimum 1-inch thick Polyurethane foam. Spray applied closed cell; thermal efficiency 'k' value 0.14 at 75 degrees F; thickness to completely fill annular space between pipe and outer jacket conduit. Flame spread / fuel contributed / smoke developed rating of 25 / 50 / 50 in accordance with ASTM E84.

G. DDT

1. The DDT manufacturer is responsible for the complete design of the DDT system, including, but not limited to, the product to be supplied, fabrication, installation, supervision, and testing of the system within the design parameters established by the contract documents, and in compliance with the detailed design. The complete design of the system shall be sealed by a Professional Engineer in the employ of the DDT manufacturer.

H. OUTER CONDUIT JACKET

1. Fiberglass reinforced polyester (FRP) resin or extruded high-density polyethylene (HDPE). FRP or HDPE with a minimum thickness of 150 mils for 24 inch and above service pipe, 125 mils for 12 inch and above service pipes and a minimum 100 mils for service pipes below 12 inches.

2.2 MANUFACTURED PREFABRICATED, JACKETED PIPING SYSTEM (SCHEDULE 80)

A. Assembly is to be rated for temperatures up to 250 deg F.

B. Manufacturers:

1. PERMA-PIPE Xtru-Therm 500.
2. Thermacor Process, LLC, Ferro-Therm.
3. Thermacor Process, LLC, Duo-Therm 505.
4. Rovanco High Temp Conduit Elite
5. Other manufacturers are not permitted.

C. SERVICE PIPE

1. Internal service piping to be Schedule 80 carbon steel, seamless, ASTM A53, Type S.
2. Joints are to be butt-welded for sizes 2-1/2 inches and larger, and socket welded for 2

inches and below.

3. End seals, gland seals and anchors shall be factory fabricated to prevent the ingress of moisture into the system.

D. SERVICE PIPE INSULATION

1. Service Pipe Insulation: Polyurethane foam, spray applied closed cell; thermal efficiency 'k' value 0.16 at 75 degrees F; thickness to completely fill annular space between pipe and outer jacket conduit. Flame spread / fuel contributed / smoke developed rating of 25 / 50 / 50 in accordance with ASTM E84. Insulation must be 1" thick for pipes 1 to 8 inches, 1-1/2" thick for 10 to 12 inches, and 2" thick for 14 to 36 inches.

E. OUTER CONDUIT JACKET

1. Fiberglass reinforced polyester (FRP) resin or extruded high-density polyethylene (HDPE). FRP or HDPE with a minimum thickness of 150 mils for 24 inch and above service pipe, 125 mils for 12 inch and above service pipes and a minimum 100 mils for service pipes below 12 inches.

2.3 MANUFACTURED PREFABRICATED, JACKETED PIPING SYSTEM (SCHEDULE 40)

A. Assembly is to be rated for temperatures up to 250 deg F.

B. Manufacturers:

1. PERMA-PIPE Xtru-Therm 500.
2. Thermacor Process, LLC, Ferro-Therm.
3. Thermacor Process, LLC, Duo-Therm 505.
4. Rovanco HDPE Jacketed Systems
5. Other manufacturers are not permitted.

C. SERVICE PIPE

1. Internal service piping to be Schedule 40 carbon steel, seamless, ASTM A53, Type S.
2. Joints are to be butt-welded for sizes 2-1/2 inches and larger, and socket welded for 2 inches and below.
3. End seals, gland seals and anchors shall be factory fabricated to prevent the ingress of moisture into the system.

D. SERVICE PIPE INSULATION

1. Service Pipe Insulation: Polyurethane foam, spray applied closed cell; thermal efficiency 'k' value 0.16 at 75 degrees F; thickness to completely fill annular space between pipe and outer jacket conduit. Flame spread / fuel contributed / smoke developed rating of 25 / 50 / 50 in accordance with ASTM E84.

E. OUTER CONDUIT JACKET

1. Fiberglass reinforced polyester (FRP) resin or extruded high-density polyethylene (HDPE). FRP or HDPE with a minimum thickness of 150 mils for 24 inch and above service pipe, 125 mils for 12 inch and above service pipes and a minimum 100 mils for service pipes below 12 inches.

2.4 PIPE ANCHORS

- A. Steel Conduit System Anchors: Prefabricated steel plate welded to pipe and conduit:

CONDUIT SIZE THICKNESS	ANCHOR PLATE
Up to 10-3/4 Inch	3/8 Inch
12 to 22 Inch	1/2 Inch
24 Inch and Larger	3/4 Inch

- B. Make concrete blocks (cast at anchor plates) large enough for firm anchorage into undisturbed trench sidewalls and bottom. Block shall be at least 30 inches long and extend 9 inches minimum beyond top and bottom of anchor plate.

2.5 PIPING IN MANHOLES

- A. Piping to be schedule 40 carbon steel, seamless, ASTM A53, Type S, except for condensate return piping which is to be schedule 80.

2.6 PIPING INSULATION AND JACKET IN MANHOLES

- A. Insulation Within Manholes: Insulation shall be 100 percent rigid cellular glass, totally inorganic, with no binder. Absorption of moisture shall be 0.2% or less per ASTM C240. Water-vapor permeability shall be 0 perm-in per ASTM E96. Average compressive strength shall be 90 psi ASTM C165. Average density shall be 7.5 lb per cubic foot per ASTM C303. Maximum service temperature shall be 900 degrees F. Thermal conductivity shall be no greater than 0.29 Btu-in/hr-sq. Ft. - degree F at mean temperature of 75 degrees F per ASTM C177 and C518. The insulation shall conform to ASTM E84 (5 Flame, 0 Smoke). Linear expansion shall be 3 inches per 100 linear feet at 600 degrees F. Insulation shall be fabricated in half sections wherever possible. For large diameter piping where half sections are not practical, curved side wall segments are preferred. Provide double layer system with staggered joints for all systems where pipe temperature is listed as 400 degrees F or greater.
- B. Jacket: Aluminum weatherproof jacket shall be manufactured from aluminum alloy 5005 or 3003 half hard, not less than 0.016 inch thick, fabricated with 3/16 inch corrugations running lengthwise of pipeline. The aluminum shall be factory attached to a moisture barrier of kraft paper treated for this service. All joints shall be made rain or drip proof. Longitudinal joints shall be located on the side of the pipe with the open edge of the lap turned down to shed water. Circumferential joints on pipes that do not have enough slope to get a good shingle effect to keep water out of the joint shall have the inside end of the lap beaded or sealed with a permanently elastic mastic type sealant designed for this service. The aluminum jacket shall be secured by aluminum straps 1/2 inch wide by 0.020 inch thick. The straps shall be placed on 12 inch centers (maximum). Each circumferential joint shall have a strap at the midpoint of the lap.

2.7 MANHOLES - PRECAST CONCRETE

- A. Pre-cast concrete structures: ASTM C478.
- B. Cast-in-place concrete: Mix 4.0A

2.8 STEAM VALVES

- A. 2 Inches and Smaller:
 - 1. Provide Class 600 or 800 gate valve (rated for 300 PSIG at 422 DEG F steam), forged or cast carbon steel body and bonnet, socket weld ends; 13 percent chromium stainless steel disc and stem; bolted or union bonnet, solid wedge disc, renewable or integral stellite or cobalt based alloy hard faced seat rings, outside screw and yoke, rising stem, body and bonnet materials to conform to ASTM A 105 or ASTM A 216, Grade WCB. Working pressure and temperature ratings shall comply with ANSI B16.34 (Standard Class).
- B. 2 1/2" Inches and Larger:
 - 1. Provide Class 300 steel gate valve (rated for 300 PSIG at 422 DEG F steam), welded ends, rising stem, flexible or solid wedge disc, renewable seat rings and disc, and bolted bonnet. Materials shall be: Body and bonnet, ASTM A 216, Grade WCB or A105; stem, 13 percent chromium stainless steel; disc face and seat rings 13 percent chromium stainless steel or a combination of 13 percent chromium stainless steel and nickel-copper, stellite or a combination of stellite and 13 percent chromium stainless steel as recommended by its manufacturer for steam service. Face to face dimension shall conform to ASME B16.10. Working pressure and temperature ratings shall comply with ASME 16.34 (Standard Class).

2.9 CONDENSATE VALVES

- A. 2 Inches and Smaller:
 - 1. Provide Class 600 or 800 gate valve (rated for 300 PSIG at 422 DEG F steam), forged or cast carbon steel body and bonnet, threaded ends; 13 percent chromium stainless steel disc and stem; bolted or union bonnet, solid wedge disc, renewable or integral stellite or cobalt based alloy hard faced seat rings, outside screw and yoke, rising stem, body and bonnet materials to conform to ASTM A 105 or ASTM A 216, Grade WCB. Working pressure and temperature ratings shall comply with ANSI B16.34 (Standard Class).
- B. 2 1/2" Inches and Larger:
 - 1. Provide Class 150 steel gate valve, flanged ends, bolted flanged bonnet, outside screw and yoke, rising stem, flexible or solid wedge disc, renewable seat rings and disc. Materials shall be: Body and bonnet, ASTM A 216, Grade WCB or A105; stem, 13 percent chromium stainless steel; disc face and seat rings 13 percent chromium stainless steel or a combination of 13 percent chromium stainless steel and nickel-copper, stellite or a combination of stellite and 13 percent chromium stainless steel as recommended by its manufacturer for steam service. Face to face dimension shall conform to ANSI B16.10. Flanges shall be faced and drilled to ANSI B16.5. Working pressure and temperature ratings shall comply with ANSI B16.34 (Standard Class). Where noted on the Contract Drawings provide an enclosed gear operator.

2.10 MANHOLE ACCESSORIES

- A. Manufacturers:
 - 1. Neenah Foundry.
 - 2. Campbell Foundry.

- B. Manhole Frames and Covers: Gray cast iron, ASTM A48, Class 30 and AASHTO H20. Where applicable, furnish covers with cast-in legend, as follows:
 - 1. Steam
 - 2. Chilled Water
 - 3. High Temperature Hot Water

- C. Manhole Frames and Covers for non-traffic areas: Fiber reinforced composite, heat resistant and watertight, equal to Fibrelight. Where applicable, furnish covers with cast-in legend, as follows:
 - 1. Steam
 - 2. Chilled Water
 - 3. High Temperature Hot Water

- D. Manhole Rungs: Galvanized Steel.

- E. Manhole Pipe Penetration Seals: Modular EPDM elastomer sealing system, rated to 20 psig (46 ft. HD), with S316 stainless steel hardware, equal to Link-Seal by GPT.

- F. Pipe Sleeves: Schedule 40 steel, ASTM A53 Grade B, with steel plate welded to sleeve, sized to accept insulated pipe and modular elastomer sealing system, i.e. Link-Seal.

- G. Wall Sleeve Sealants: Jute or oakum backing with plastic or bitumastic caulking compound, gunned into external annular space between insulation and sleeve.

- H. Damp proofing: Non-asbestos, asphaltic bitumen, trowel grade.

- I. Venting: Install goose neck vents, 6" schedule 40, insulated with aluminum jacket. One vent is to terminate 24 inches above the bottom of the manhole. The second is to terminate 6 inches below the top to the manhole to help establish a convection cell to ventilate the manhole.

PART 3 EXECUTION

3.1 MANHOLES

- A. Set manhole tops flush with landscaped and paved areas.
- B. Use epoxy bonding compound where rungs are grouted into walls of field-built manholes.
- C. Provide concrete skirts around manhole and vent line openings.
- D. Apply damp proofing to exterior side of pre-cast concrete or field build masonry manholes.

3.2 PIPING INSTALLATION

- A. Drawing plans, schematics, and diagrams indicate general location and arrangement of piping systems. Install piping as indicated unless deviations to layout are approved on Coordination Drawings.
- B. Install piping in concealed locations unless otherwise indicated and except in equipment rooms and service areas.

- C. Install piping indicated to be exposed and piping in equipment rooms and service areas at right angles or parallel to building walls. Diagonal runs are prohibited unless otherwise indicated.
- D. Install piping above accessible ceilings to allow sufficient space for ceiling panel removal.
- E. Install piping to permit valve servicing.
- F. Install piping free of sags and bends.
- G. Install fittings for changes in direction and branch connections.
- H. Install piping to allow application of insulation.
- I. Select system components with pressure rating equal to or greater than system operating pressure.
- J. Install groups of pipes parallel to each other, spaced to permit applying insulation and servicing of valves.
- K. Install drains, consisting of a tee fitting, NPS 3/4 full port-ball valve, and short NPS 3/4 threaded nipple with cap, at low points in piping system mains and elsewhere as required for system drainage.
- L. Install steam supply piping at a minimum uniform grade of 0.2 percent downward in direction of steam flow.
- M. Install condensate return piping at a minimum uniform grade of 0.4 percent downward in direction of condensate flow.
- N. Reduce pipe sizes using eccentric reducer fitting installed with level side down.
- O. Install branch connections to mains using mechanically formed tee fittings in main pipe, with the branch connected to top of main pipe.
- P. Install valves according to the following Sections or other Sections as needed:
 - 1. Section 230523 "Valves for HVAC Piping."
- Q. Comply with requirements in Section 230516 "Expansion Fittings and Loops for HVAC Piping" for installation of expansion loops, expansion joints, anchors, and pipe alignment guides.
- R. Comply with requirements in Section 230553 "Identification for HVAC Piping and Equipment" for identifying piping.
- S. Install drip legs at low points and natural drainage points such as ends of mains, bottoms of risers, and ahead of pressure regulators, and control valves.
 - 1. On straight runs with no natural drainage points, install drip legs at intervals not exceeding 300 feet.
 - 2. Size drip legs same size as main. In steam mains NPS 6 and larger, drip leg size can be reduced, but to no less than NPS 4.

3.3 STEAM AND CONDENSATE PIPING SPECIALTIES INSTALLATION

- A. Comply with requirements in Section 232216 "Steam and Condensate Heating Piping Specialties" for installation requirements for strainers, flash tanks, special-duty valves, steam traps, thermostatic air vents and vacuum breakers, and steam and condensate meters.

3.4 PREFABRICATED PIPING APPLICATION

Pre-Fabricated Piping System	Applicable SCUB System
Perma Pipe MT 750	Steam
Perma Pipe Xtru-therm 500	Steam Condensate Return Chilled Water High Temp Hot Water Dual Temp Water Glycol Cooling Water Domestic Hot Water Condenser Water
Thermacor Duo-Therm 505	Steam High Temp Hot Water Steam Condensate Return
Thermacor Ferro-Therm	Chilled Water Heating Water Dual Temp Hot Water Domestic Hot Water Steam Condensate Return Condenser Water Glycol Cooling Water
Rovanco HDPE Jacketed Systems	Chilled Water Heating Water Dual Temp Hot Water Domestic Hot Water Steam Condensate Return Condenser Water Glycol Cooling Water
Rovanco High Temp Conduit Elite	Steam High Temperature Hot Water Steam Condensate Return

3.5 SERVICE PIPING INSULATION SCHEDULE

Pipe Size (in.)	Minimum Insulation Thickness (in.)	
	Steam, Steam Condensate Return, High Temp Hot Water, Dual Temp, Domestic Hot Water, Condenser Water	Chilled Water, Glycol Cooling Water
1 to 8	1	1
10 to 12	1-1/2	1
14 to 36	2	1-1/2

3.6 PIPING SYSTEM INSTALLATION

- A. Install 1-inch bypass valve around all steam and condensate return shutoff valves for system warm-up.
- B. Install insulation on field joints after radiographic and pressure testing are completed and accepted.

3.7 PIPED UTILITY DEMOLITION

1. Disconnect, demolish, and remove piped utility systems, equipment, and components indicated to be removed. Piping to Be Removed: Remove portion of piping indicated to be removed and cap or plug remaining piping with same or compatible piping material.
2. Disconnect, demolish, and remove piped utility systems, equipment, and components indicated to be removed. Piping to Be Removed: Remove portion of piping indicated to be removed and cap or plug remaining piping with same or compatible piping material.
3. Piping to Be Removed: Remove portion of piping indicated to be removed and cap or plug remaining piping with same or compatible piping material.
4. Piping to Be Abandoned in Place: Drain piping. Fill abandoned piping with flowable fill, and cap or plug piping with same or compatible piping material.
5. Equipment to Be Removed: Disconnect and cap services and remove equipment.
6. Equipment to Be Removed and Reinstalled: Disconnect and cap services and remove, clean, and store equipment; when appropriate, reinstall, reconnect, and make operational.
7. Equipment to Be Removed and Salvaged: Disconnect and cap services and remove equipment and deliver to Owner.
8. If pipe, insulation, or equipment to remain is damaged in appearance or is unserviceable, remove damaged or unserviceable portions and replace with new products of equal capacity and quality.

3.8 FLUSHING

- A. Piping is to be flushed thoroughly with a preflush using compressed air and final flush with steam prior to being placed into service. Use of a target board is to be used to determine if pipe is free of slag and oil.
- B. Steam system flush.
 1. Provide temporary piping and spool pieces as required to properly flush, clean and vent air/steam safely to the outdoors.
 2. Provide spool pieces at equipment subject to damage or clogging during flushing. Devices include but are not limited to.
 - Pressure reducing valves
 - Control Valves
 - Steam Traps
 - Gauges and Sensors

3. Flush pressure shall not exceed the specified working pressure of the system.
4. The initial flush shall be with steam. Strainers shall be removed during the initial flush and the strainer pockets shall be cleaned of debris between each flush.
 - Steam shall be slowly introduced to the system via warm-up and throttling valves to bring the pipes up to temperature. Condensate shall be drained from the system during warm-up via low point drains and drip-legs. Once the system is sufficiently warm flushing may begin.
 - Steam flush 3 times.
 - Steam flushing shall occur in a similar manner to air flushing with a recommend a flushing velocity of 12,000 FPM.
 - Strainers shall be removed and cleaned after each flush. Piping system shall be drained of condensate from low points and drip-legs after each flush.
 - Steam flushes shall be performed until dirt and debris is no longer observed in the strainers or discharge.
 - Clean Target boards also may be used to help determine if piping is clear of dirt and debris.
5. Upon completion and acceptance of flushing by UM, the temporary piping and spool pieces shall be removed, and permanent system devices shall be reinstalled.

C. Hydronic system flush.

1. A pump shall be sized to meet a fluid velocity of 6 FPS in the largest pipe main. Add by-pass piping for continuous circulation at each end.
2. Fill system with fresh water and circulate for 12-24 hours and flush to remove large sediment first.
 - Backflow preventer shall be installed on domestic water make up water system.
 - Verify system drain downs near an approved sanitary sewer drain.
3. Drain system from lowest possible point and refill with fresh water.
4. Add System Cleaner: liquid alkaline compound with emulsifying agents and detergents to remove grease and petroleum products. Closed system cleaner at a dosage of 15 gallons per 1000 gallons (or recommended dosage per water treatment contractor) and circulate for 24 hours.
5. Drain system from lowest points until the pH is equal to fresh potable water make up (>8.0).
6. Circulate the system water again after flushing for 12 hours, then drain system again.
7. If system water is clean at test valves on lower section of system proceed to next step. If the system is still turbid fill and circulate for another 12 hours and flush until it is clear.

8. Refill system with fresh water and add corrosion inhibitor to system water to achieve the desired residual (50-150ppm).
9. The system must be tested after 2 weeks of operation to ensure the chemical residual is adequate and maintained.
10. Submit written proof of cleaning and flushing. Report is to include largest main, circulating pump size (flow and head), system volume (in gallons), amount of cleaning agent added (in gallon), flush start date and time and end date and time, amount of chemical added, water quality parameters and chemical residual after 2 week operation period.
 - Provide redline drawings highlighting the piping that was flushed and locations of bypass.
11. The water treatment contractor shall test water quality in existing systems and submit report to UMD O&M prior to opening up the new system to the existing system.

3.9 FIELD TESTING

- A. Underground piping joints are to be radiographically tested 100%. Radiographic films are to be submitted to the energy distribution operator and University.
- B. Conduit is to be air tested at 15 psig for a 4-hour duration.
- C. Service pipe is to be hydrostatically tested at 1-1/2 times the system operating pressure (125 psig x 1.25 = 156 psig) for a 12-hour duration.
- D. Provide pressure test reports for all piping system pressure tests. Pressure tests are to include start date, time and pressure and end date, time and pressure. Any pressure increase or drop that exceeds 1.5% of test pressure or 2 psig (whichever is less) will be considered a failed test.
- E. Correct leakage and retest as required.
- F. Submit test report.

3.10 IDENTIFICATION

- A. Piping Systems: Install pipe markers on each system. Include arrows showing normal direction of flow.
- B. Plastic markers, with application systems. Install on insulation segment if required for hot noninsulated piping.
 1. Locate pipe markers on exposed piping according to the following:
 2. Near each valve and control device.
 3. Near each branch, excluding short takeoffs for equipment and terminal units. Mark each pipe at branch if flow pattern is not obvious.
 4. Near locations where pipes pass through walls or floors or enter inaccessible enclosures.
 5. At manholes and similar access points that permit view of concealed piping.
 6. Near major equipment items and other points of origination and termination.

3.11 Backfill

- A. A 6-inch layer of sand or fine gravel shall be placed and tamped in the trench to provide uniform bedding for the system. The entire trench shall be evenly backfilled with a similar material as the bedding in 6-inch compacted layers to a minimum height of 6 inches above the top of the insulated piping system. The remaining trench shall be evenly and continuously backfilled in uniform layers with suitable excavated soil.
- B. Backfill with sand, and hand-tamp to depth of 12 inches above top of conduit.
- C. Install PVC warning tape directly above system.
- D. Refer to trench detail below.

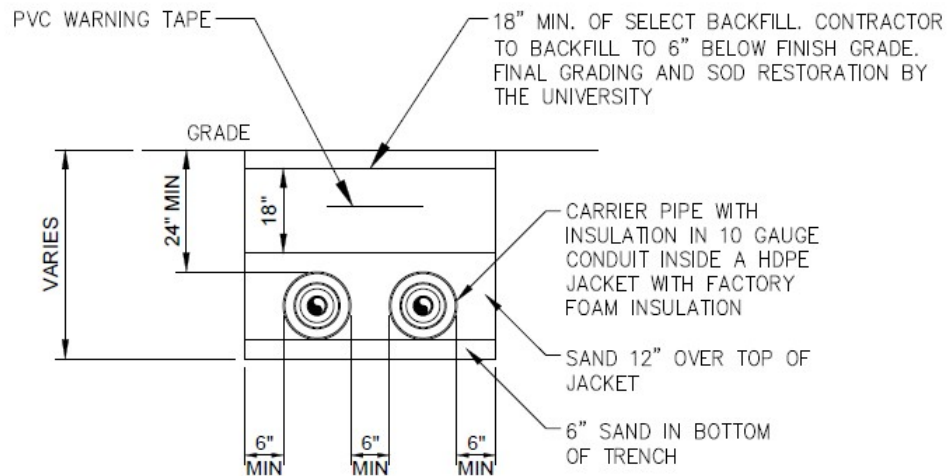

3.12 MANUFACTURER'S FIELD SERVICES: Follow Section 01400.

- A. Provide services of a qualified, factory-trained installation instructor to ensure that system is installed in accordance with manufacturer's recommendations and accepted submittals.
- B. Upon completion, furnish a certificate from manufacturer stating that installation has been made in accordance with recommended procedures.

END OF SECTION 33 63 00