

Description:

The purpose of the section is to highlight the current applicable UMD Design Standards for the design of interior graphic/signage.

Related Sections:

- 10 14 01 Exterior Building Signs

Effective Date:

January 1, 2021

Applicable Standards:

- ADA Guidelines (current edition)

General Requirements:

- The design shall include an identification and directional system to communicate information essential to the operation of the new facility.
 - The interior/exterior graphic system is to assist individuals moving to and within the facility.
 - Particular attention must be given to the needs of individuals with disabilities to permit their access to the building from parking areas and walkways and to move freely throughout the building.
- It is imperative that the interior graphic system meets critical maintenance, replacement, and anti-vandalism specifications with regard to location and method of application, as well as design specifications for material, color, texture, dimensions, and letter type.
 - These requirements also apply to painted wall graphics.
- The development of the interior signage system and all supplementary graphics specific to the project shall be coordinated with the Project Manager.
 - The specific room numbering assignments are to be conducted by Facilities Planning at the completion of the Schematic Design Phase.
 - All rooms shall be numbered on the drawings using the University room numbering standard.
- The design is to be in accordance with the following references:
 - Interior Room Numbering Standard- In order to properly identify rooms, assign space and maintain a computerized space inventory and key control, the following room numbering and identification system is in use at the College Park Campus (See Figure 1):
 - Each floor within a building is to be assigned a group of 4-digit numbers. The first digit will indicate the floor of the building, the second will indicate the wing, and third and fourth will indicate the room number in that wing.
 - The four digit number may have an alpha prefix indicating a sub-basement (SB0123), basement (B0123) or mezzanine (M1123), or an alpha suffix indicating a part of one room or space (1123A).
 - Small rectangular buildings will be numbered using 4-digits, where the first digit will indicate the floor, and the last two digits shall indicate the room number and the second digit shall be "one".
 - Each room entered from a public corridor will have a separate room number.
 - Room Numbering shall read with even numbered rooms on one side of the public corridor and odd numbered rooms on the opposite side. (See figure 2.)
 - Rooms with more than one door opening into the public corridor shall have the same number plate. Where spaces are not entered from a public corridor, but from another space, they will be assigned the same room number with an alpha suffix.
 - Room number suffixes shall be assigned in a clockwise direction.

- If the spaces begin only to the right of that spaces entrance then alpha suffixes shall be assigned in a counterclockwise direction. Note: In the alpha suffix system, letters "I" and "O" are not assigned. When the letter "Z" is passed, continue with AA, BB, etc.
- The room numbering system must be flexible enough to accommodate physical changes which may occur during the life of the building. The most frequent changes will be the subdivision of larger rooms into smaller rooms. In cases where long rooms run parallel with the corridor, a block of numbers will be reserved so that if future subdivisions do occur, numbers will be available for the spaces without renumbering the entire wing.

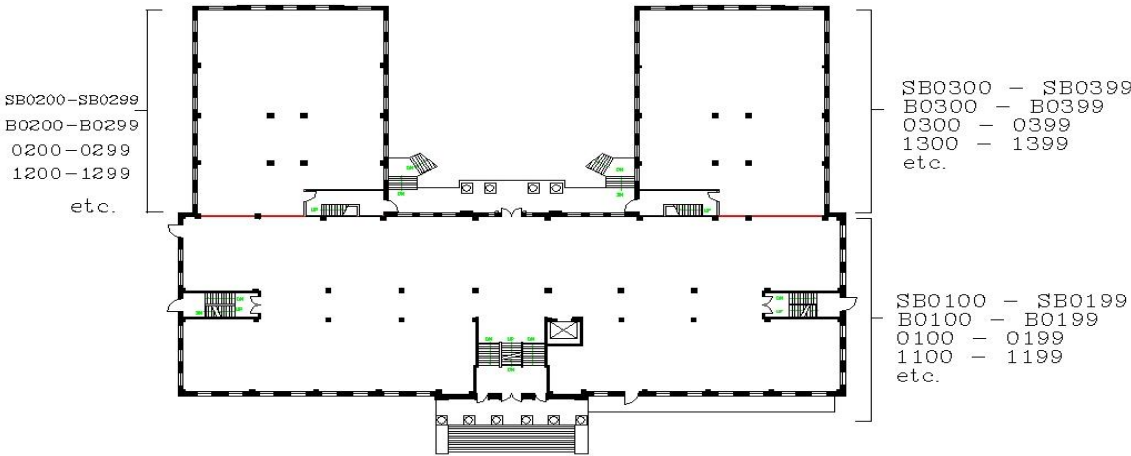
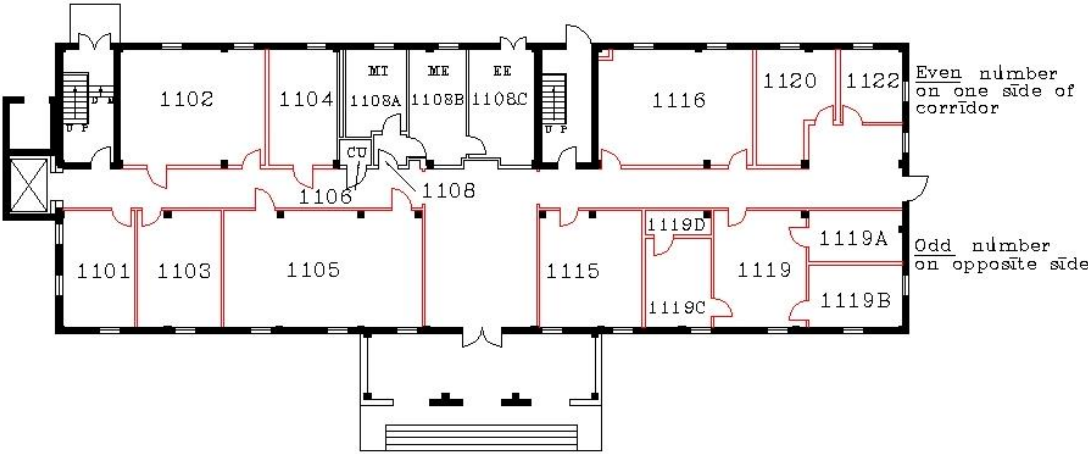

Figure 1

Figure 2



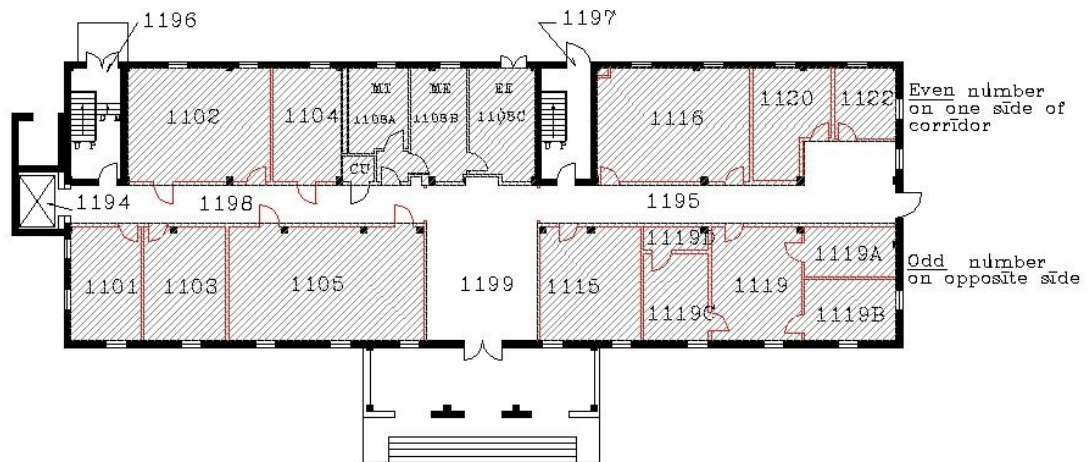

Figure 3

- The numbering system should reflect a general location within the building. This can be done most easily by "stacking" room numbers as much as possible. For instance, room 1101 should be in the same relative position in the building as room 2101 and 3101.
- All public corridors, lobbies, elevators, lifts, and stairways will be numbered starting from 99 and going down, i.e., 1199, 1198, 1197, 1196, etc. (See FIGURE 3.)
- **Identification System**
 - All building support areas will be marked with a sign identifying its room use. Building support areas include: mechanical, electrical, elevator and telephone equipment rooms, custodial closets, and toilets.
 - For these support spaces all drawings are to reflect the following abbreviations:
 - Mechanical equipment rooms - ME
 - Electrical rooms, transformer vaults - EE
 - Elevator machinery - X
 - Telephone equipment - TE
 - Custodial closets - CU
 - Men's Rooms - MT
 - Women's Rooms – WT
 - Unisex/Family Restroom - UT
 - Bathroom - T
 - All signage for these spaces will be worded as follows to provide uniformity:
 - Mechanical equipment rooms - "MECHANICAL EQUIPMENT"
 - Electrical rooms, transformer vaults - "ELECTRICAL EQUIPMENT"
 - Elevator machinery - "ELEVATOR EQUIPMENT"
 - Telephone equipment - "TELEPHONE EQUIPMENT"
 - Custodial closets - "CUSTODIAL"
 - Men's Rooms - "MEN"
 - Women's Rooms - "WOMEN"
 - Family Restrooms – "All Gender "
 - Bathroom - "RESTROOM"

- Assignment of Room Numbers to New Buildings**
 - Design drawings shall incorporate room numbering in accordance with the UM Room Numbering Standard identified above.
 - Before working drawings are completed, the doors that are scheduled to have room # plates and/or room identification signs shall be identified.
 - At the completion of construction, all "As Built" floor plans (architectural, mechanical, electrical, and structural) shall reflect the room numbers as installed by the contractor.
- Assignment of Room Numbers for Renovation Projects**
 - Before any renovation begins, Facilities Planning will mark room numbers on two (2) set of plans in accordance with the Standard Room Numbering and Room Identification System, indicating what room numbers and room identification sign are required.
 - One set will be used to incorporate the information on the working drawings, and the second set will be distributed to Facilities Management O&M Building Security.
 - At the completion of the renovation, "As Built" drawings, verifying work done and installation of the required room number plates and room identification signs shall be prepared.
 - The cost for the fabrication and installation of room number plates and room identification signs will be included in the cost of renovation.
- Interior Room Identification Sign Detail**

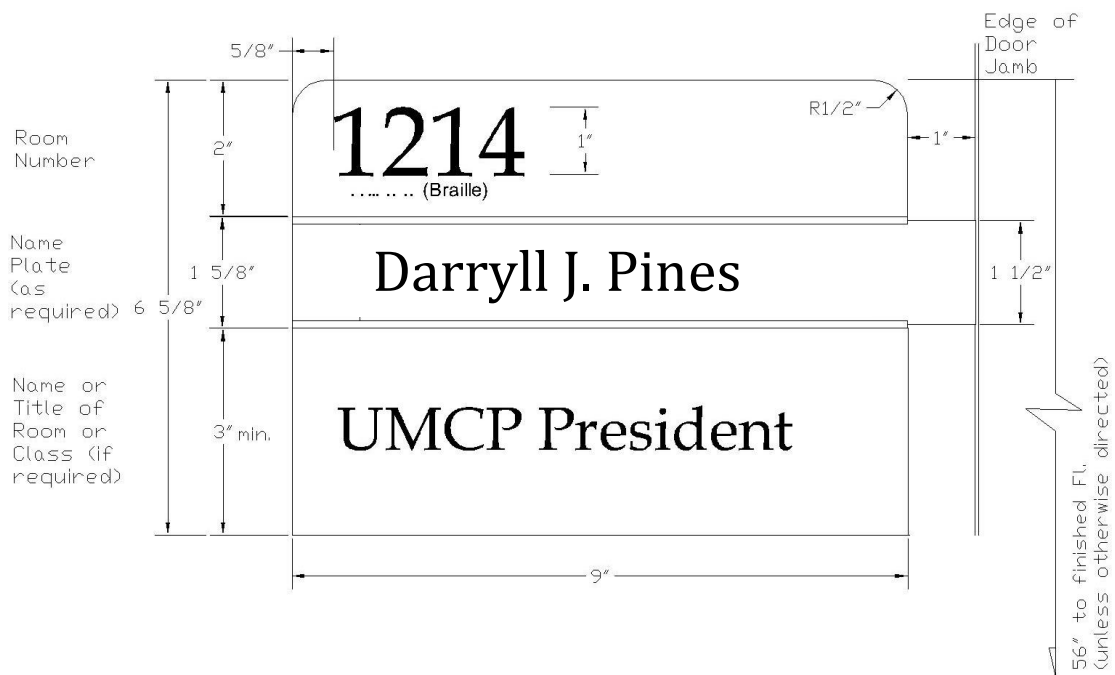

Figure 4 (for non-permanent rooms with removable nameplate)

- Interior Room Identification Guidelines**
 - All room numbers shall be engraved in a non-glare ultra-matte finish 1/16" engraving stock (Romark, or equivalent) with 1" tactile characters, raised minimum 1/32" and include Braille cell below the room number.
 - All characters shall be uppercase. (See Figure 4)

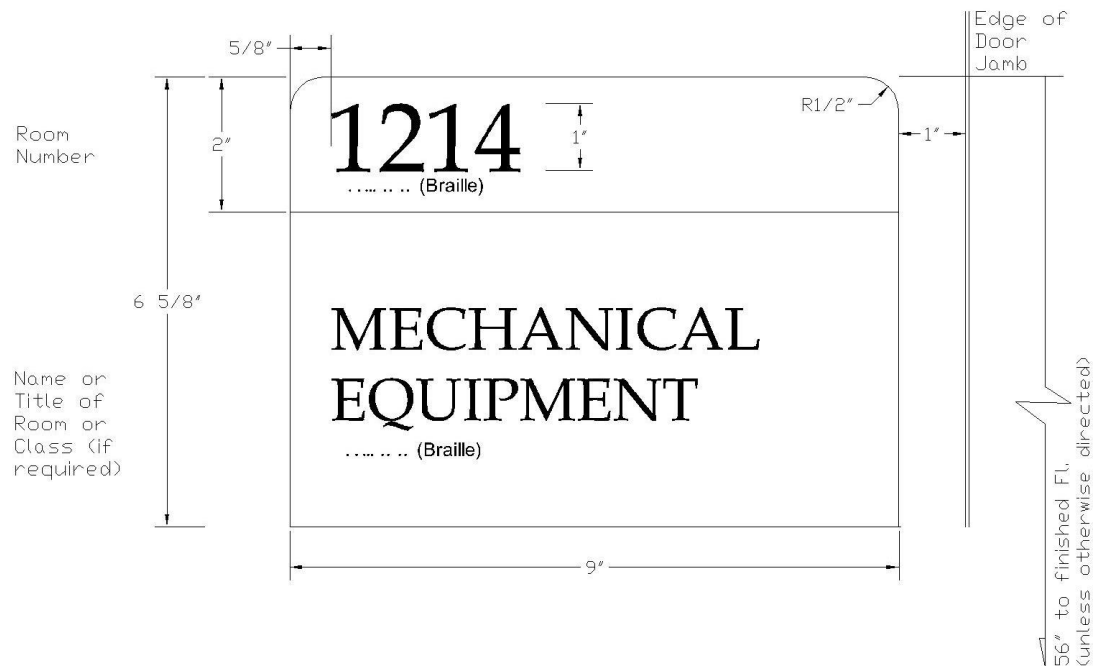

Figure 5 (for permanent assigned rooms)

- All permanent assigned rooms shall be engraved in a non-glare reverse engraveable ultra-matte finish 1/16" engraving stock (Romark, or equivalent) with minimum 5/8" tactile characters, raised minimum 1/32" and include Braille cell below verbiage.
 - Restrooms, stairwells, floor designators, mechanical equipment, electrical equipment, telecommunications equipment and elevator equipment fall into this category. All characters shall be uppercase. (see Figure 5)
- Non-permanent room names shall be engraved in a non-glare ultra-matte finish 1/16" engraving stock (Romark, or equivalent).
 - Character height may vary depending on length.
 - Characters shall be upper/lower case.
 - Characters shall be conventional in form. Sizes of plates can be 4 5/8" x 9" or 3" x 9". (see Figure 4)
- All nameplates shall be engraved in a non-glare ultra-matte finish 1/16" engraving stock.
 - Character height may vary depending on length.
 - Characters shall be upper/lower case. Size will be 1.5" x 9".
 - Nameplates are to slide into a 1 5/8" x 9" aluminum bracket in silver or anodized black or gold pending on scheme and design constraints.
 - Color shall be determined by project manager and approved by the Sign and Graphics Shop before bidding.
 - Font is to be "Bembo" throughout.
 - The project manager and the Sign and Graphics Shop will accept no deviance without prior signed approval.

- All room numbers, nameplates, and room identification signs will be adhered to 1/8" thick finish PVC material (Sintra, Celtec, Komacel, Komatex, or equivalent) with 3M VHB Very High Bond Joining Systems #9473 double-sided tape (or equivalent).
 - All signs to be mounted on block wall shall have the entire perimeter of the sign taped with 3M double-sided black tape #4432 (or equivalent).
 - All signs mounted on drywall, wallboard, etc. shall be installed with 1.25" x #6 counter sunk Phillips head screws.
- Signs shall be installed one inch from the latch side of the casing jamb to the leading edge unless architectural barrier or overriding design constraint exists.
- If required as part of a project, coordination between the user, Department of Operations and Maintenance, and the Department of Planning and Construction is required to determine specific requirements and acceptable manufacturers.
- Wayfinding System: Criteria for All Gender Inclusive Signage
 - Current UMD directives request that designers consider any and all types of wayfinding signage system for new or large renovation construction projects that identify/address specific signage devices that direct in a positive manner a "Gender Inclusive" building and campus environment.
- Laboratory Hazardous Material Signage:
 - Future UMD directives will request that designers coordinate the design/color/placement of laboratory room identification signage on new construction or large renovation projects. Designers are required to coordinate for exact wall locations with UMD-PM and UMD-ESSR department.