

Description:

The purpose of the section is to highlight the current applicable UMD Design Standards for the design of building service/maintenance support within buildings.

Related Sections:

- TBD

Effective Date:

January 1, 2020

Applicable Standards:

- National Electrical Code for "Classified Locations"

General Requirements:

The spaces identified in this section shall not be used as access to other spaces.

• **Housekeeping Zone Closets:**

- Provide a minimum of one (1) 4'-6" x 8'-0" housekeeping closet with double doors on each floor of a building (see attached floor plan for layout of closet and the table identifying number of closets required).

The following shall be standard equipment in each housekeeping closet:

- 36" X 36" floor mounted pre-cast mop-ceptor.
 - 36" shelf above mop-ceptor.
 - Mop strip above mop-ceptor.
 - Mop-ceptor faucet shall have threaded spout with pail hook and 6 foot hose with racket.
 - One electrical outlet.
 - One light fixture switched to door opening.
 - Trap primer and accessories.
 - Floors and walls (to at least 4'-0" high above finished floor) shall be covered with hard, waterproof surfaces, preferably ceramic tile.
 - One additional closet shall be provided that is large enough to house an automatic scrubber (48" x 60" x 48" high) in buildings of 40,000 GSF or larger. For units that do not utilize sealed batteries, the electrical lighting, fans, wiring, etc., shall comply with the requirements of the National Electrical Code for "Classified Locations". The exhaust fans shall operate 24 hours per day.
 - Only equipment identified in this section shall be located in housekeeping closets. Installation of HVAC, electrical, telephone or plumbing equipment is not acceptable.
 - A set of double doors is required for each housekeeping closet. Each door (minimum 30" each) shall swing out into the corridor.
- **Housekeeping Central Storage Room:**
- A 200 GSF storage room (minimum) located adjacent to a loading dock or service entry is required in buildings of 40,000 GSF or larger.
- **Housekeeper's Room:**
- Provide one 100 GSF room per building (minimum), located adjacent to housekeeping central storage room.
 - The size of this room increases in increments of 15 GSF for each additional 20,000 GSF of building.
- **Preventive Maintenance Shop:**
- Provide one 100 GSF room per building (minimum), located adjacent to primary mechanical room(s) and loading dock or service entry.
- **Preventive Maintenance Storage:**
- If a building is 40,000 GSF or larger, a 200 GSF room (minimum) separate from, but adjacent to, the maintenance shop, is required. The size of this room increases in increments of 20 square feet per each additional 20,000 GSF of building.

HOUSEKEEPING ZONE CLOSET

Legend

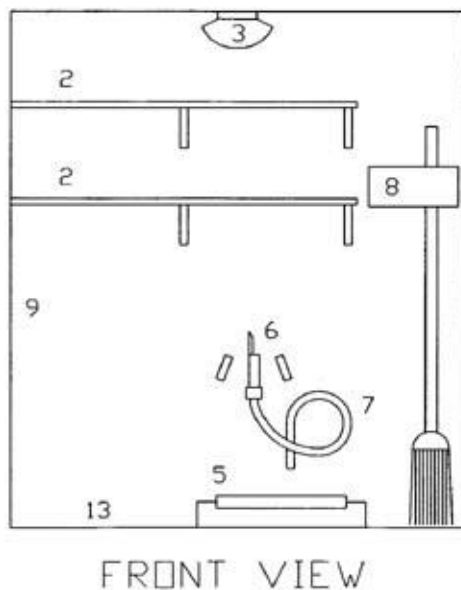
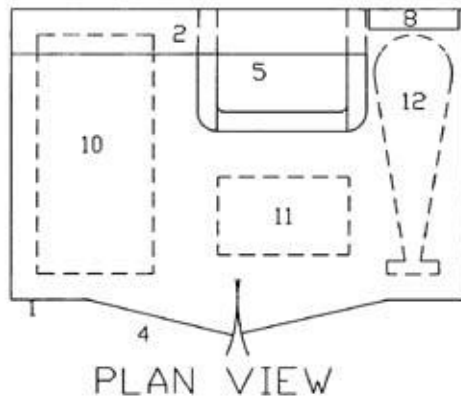

1. Dimensions: 8' long, 4 1/2' deep.
2. Shelving 10" deep, with bracket supports.
3. Fluorescent fixture with switch mounted occupancy control that utilizes 180 degree field of view.
4. Two 30" doors, with vents and lockable.
5. Utility floor sink, (note: off-center) with stainless steel lip cover.
6. Bibb faucet with support hanger.
7. 4 foot length of hose.
8. Tool holder.
9. Walls ceramic to 4' min., painted enamel (including ceiling) above 4'.
10. Location for housekeeping cart or waste hamper.
11. Location for 2-bucket (or 3-bucket) mopping outfit.
12. Location for floor machine or vacuum.
13. Floor--hard, water-proof surface, preferably ceramic tile.

NOT DRAWN TO SCALE

Building Services & Preventive Maintenance Requirements

01.92.00

Legend

11. Dimensions: 8' long, 4 1/2' deep.
12. Shelving 10" deep, with bracket supports.
13. Fluorescent fixture with switch mounted occupancy control that utilizes 180 degree field of view.
14. Two 30" doors, with vents and lockable.
15. Utility floor sink, (note: off-center) with stainless steel lip cover.
16. Bibb faucet with support hanger.
17. 4 foot length of hose.
18. Tool holder.
19. Walls ceramic to 4' min., painted enamel (including ceiling) above 4'.
20. Location for housekeeping cart or waste hamper.
21. Location for 2-bucket (or 3-bucket) mopping outfit.
22. Location for floor machine or vacuum.
23. Floor--hard, water-proof surface, preferably ceramic tile.

Building Size(GFS)	Zone Closets #	SF@4' X8.5'	Central Storage	Housekeeper room	Shop	Storage	Total GSF	Pct of GSF
20,000	1	36	None Requ	100	100	None Requ	236	1.18%
40,000	2	72	200	115	100	200	687	1.72%
60,000	3	108	220	130	100	220	778	1.30%
80,000	4	144	240	145	100	240	869	1.09%
100,000	5	180	260	160	100	260	960	0.96%
120,000	6	216	280	175	100	280	1,051	0.88%
140,000	7	252	300	190	100	300	1,142	0.82%
160,000	8	288	320	205	100	320	1,233	0.77%
180,000	9	324	340	220	100	340	1,324	0.74%
200,000	10	360	360	235	100	360	1,415	0.71%
220,000	11	396	380	250	100	380	1,506	0.68%
240,000	12	432	400	265	100	400	1,597	0.67%
260,000	13	468	420	280	100	420	1,688	0.65%
280,000	14	504	440	295	100	440	1,779	0.64%
300,000	15	540	460	310	100	460	1,870	0.62%
<p>Zone Closets are the basic work and supply room for individual housekeepers and should be located adjacent to restrooms. Housekeeping Central Storage is the storage room for the building and should be convenient to both the service entry, loading dock and the elevator. Housekeeper Room is the lunch, meeting and office facility. It should be adjacent to the Central Storage Room. Maintenance Shop is the basic work area for the building maintenance. It should be located adjacent to the service entry and main mechanical space. Maintenance Storage Room is the supply storage area for maintenance and should be located adjacent to the Shop and Service entry.</p>								